

Pulsed Neural Networks for Image Processing

V. Paukštaitis, A. Dosinas

*Department of Electrical and Control Equipment, Kaunas University of Technology,
Studentų str. 50, LT-51368 Kaunas, Lithuania, phone: +370 37 300270, e-mail: kat0102@ktu.lt*

Introduction

Cellular neural networks were introduced in 1988 [1] as an alternative to the usual artificial neural networks. The cellular neural networks emerge were stimulated by the huge need of the parallel processes in the automated information processing systems and especially in the field of image processing systems. The development of such artificial networks is stimulated also by the fact that biological well working sensory system is cell formed, i.e. out of the elements carrying on their elementary functions. The emerge of the cellular neural networks has widen the bottleneck in the information processing path, although the persisting problem is how to make up the image analysis system suitable for many cases, yet reliable, fast and trainable by given classified images.

The cellular neural networks may be realized by analogue and digital circuits. There are applied analogue and digital signal processing approaches, both integrated together, in this work. Such neural networks are called *pulsed cellular neural networks* throughout the various papers.

There are known some digital realization methods described in the literature. For example, the robot avoiding obstacles by utilizing visual information has been manufactured [2]. The membrane potential of the neuron is modelled by common digital counters consisting of flip-flops. The reaction pulse springs up when the contents of the counter is above certain level.

However, many of the image processing tasks requires huge amount of parallel processes to achieve high processing speed [3]. This leads to huge amount of parallel connected processing elements. In this case, the analogue devices are more superior due to the fact, that they occupy less space in the integrated circuits. Such analogue devices are designed and the created system has been applied to segment the images by adapting the weights of the artificial neurons [4].

The information streams model of the pulsed neural cells is under scope in this work to research it's working characteristics, to find possible essential operation peculiarities in the physical systems, to work-out data

input-output visualization subsystem and test the model of the system while processing the images.

Theoretical Model

In the most general case, any linear layer of artificial neural network in its base serves as multiplication and addition operator:

$$g(\mathbf{X}, \mathbf{W}) = \sum_{i=0}^N w_i x_i, \quad (1)$$

where w_i - weight, showing how much input signal x_i has the influence into the output, N - quantity of inputs. \mathbf{X} and \mathbf{W} are the input signals' vector and their weights vectors, respectively. Sum (1) will express non-linear space when it is passed in as the non-linear function argument:

$$y(\mathbf{X}, \mathbf{W}) = f(g(\mathbf{X}, \mathbf{W})), \quad (2)$$

where f - non-linear function in the general case.

Operation (2) mostly is base operation in various image processing procedures where the convolution operation is applied extensively [3]. Discrete one dimensional convolution can be written as follows:

$$z_j(\mathbf{X}, \mathbf{W}) = \sum_{i=j}^{N+j} w_{i-j} x_i. \quad (3)$$

It is easy to notice by comparing (1) and (3) expressions that artificial neural network may perform the convolution of vectors \mathbf{X} and \mathbf{W} . Such artificial neural network performing convolution is shown in the Fig. 1.

Input and output signals of the artificial neural network are expressed as pulses in this paper. The value of the i -th input signal is defined as the sequence of pulses with identical amplitude and width. The physical realization of the expression (3) may be easier understood by portraying the model of the electronic single outputted device which calculates the convolution. For such reasons the pulsed neural network cell is applied which has two positive inputs, as shown in Fig. 2. The cell converts the

sequences of pulses into analogue signal, processes it and springs the output pulsed signal. The artificial neuron accumulates the tension depending on the count of incoming pulses. The tension in the artificial neuron in the general case can be expressed as:

$$V(t) = A_0 h(\tau_1, t), \quad (4)$$

where A_0 – amplitude of the pulse, τ_1 – integration factor, t – time, h – impulse response function.

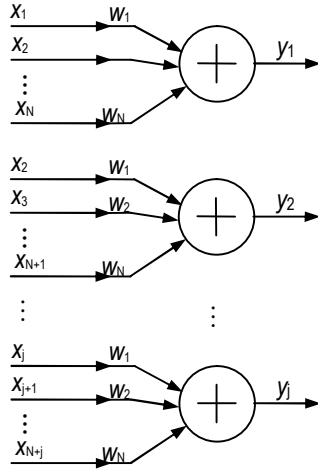

Fig. 1. Artificial neural network as convolving device

In such case, the artificial neuron will accumulate tension and the signal projecting that tension will rise until saturation and afterwards the tension will not reflect the tension supplied by input signals.

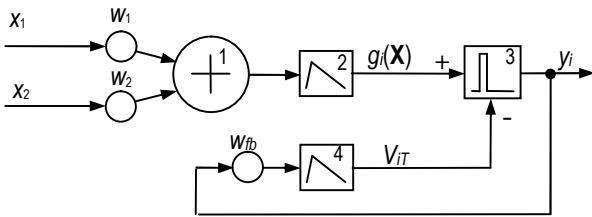

Fig. 2. The pulsed artificial neuron: 1 – adder, 2, 4 – integrators, 3 – comparator and pulse formation unit

The accumulated tension should be discharged to avoid such information loss due to saturation effect. Such process is expressed introducing yet more one time constant τ_2 predetermining the discharge speed of the tension in the artificial neuron. Let the charge pulse appears at the moment t_0 and ends at the moment t_1 ($T_{PH} = t_1 - t_0$ is the charging pulse width) then the expression (1) evolves into:

$$V(t) = A_0 (h(\tau_1, t) - h(\tau_2, t)), \quad (5)$$

where $\tau_1 \ll \tau_2$. This way, having the constant count of charging pulses the tension is around its mean value which reflects the tension supplied by incoming pulses.

The intra-cellular tension reflects the influence of all inputs. If the input signal is multiplied by the corresponding weight w_i , expressing the magnitude of the input influence, then the expression (5) evolves into following:

$$g_i(\mathbf{X}, t) = \left(\sum_{j=i}^N w_j A_0 \right) (h(\tau_1, t - t_0) - h(\tau_2, t - t_1)). \quad (6)$$

After the charge pulse, the cell's output signal is formed by such rule:

$$y_i = \begin{cases} A_0(T_{PH}), & \text{if } g(\mathbf{X}) > V_{iT} \\ 0, & \text{else} \end{cases}, \quad (7)$$

where $A_0(T_{PH})$ – output pulse having T_{PH} width and amplitude A_0 .

The inner tension $g(\mathbf{X})$ is compared to a threshold which is the sum of the feedback signal and its weight products:

$$V_{iT}(t) = (w_{fb} y_i) (h(\tau_3, t - t_2) - h(\tau_4, t - t_3)), \quad (8)$$

where w_{fb} – feedback weight, t_2 – the appearance time of the output pulse, t_3 – the end of the output pulse, τ_3, τ_4 – charge and discharge time constants. Note, that $(\tau_4 \gg \tau_3) \gg (\tau_2 \gg \tau_1)$.

Concluding the artificial neural cell's work cycle, it may be divided into such steps:

- a) the quantized pulses as input signals are applied;
- b) g_i signal is obtained by summing the weighted pulses in the synapses;
- c) the value of threshold V_{iT} is obtained from the output signal coming to the feedback loop;
- d) the output signal is formed when signal g_i is greater than V_{iT} signal;
- e) threshold value V_{iT} is increased by the output pulse which is in the feedback loop.

Experimental Results

The tension accumulation function in the pulsed artificial neural networks may be implemented applying the capacitors in the integrated circuits. The capacitance can be charged or discharged by two ideal sources. By connecting the current source the voltage on the capacitance is changing near linear function and by connecting the voltage source the capacitance's voltage is changing near exponential function. This way the response function $h(\tau, t)$ will be linear and in the other case – exponential in the expressions (6) and (8). The experimental setup was assembled to test the performance peculiarities of such artificial pulsed neural network. The experimental setup schematics are presented in Fig. 3.

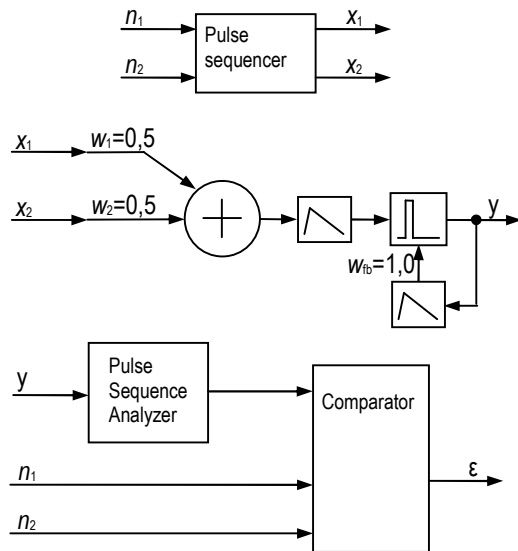

Fig. 3. The experimental setup of artificial neural system

Table 1. Charging-discharging loop's parameters

Common characteristics	
Resolution/Dynamic Range [pulses]	32
Minimal Pause [relative pulses]	9
Exponential response characteristic	
Tension magnifier	1
Tension decrease time constant [relative pulses]	0.7
Threshold magnifier	adaptive
Threshold decrease time constant [relative pulses]	50
Linear response characteristic	
Tension magnifier	0.5/input
Tension decrease	0.0085
Threshold increase	0.18
Threshold decrease	0.0085

The pulse sequencer converts the non-dimensional number into the sequence of pulses. The maximal possible quantity of pulses will determine the dynamic range of the neural system. The pulses are placed applying the equal probability randomization. Let's assume the pulse width is relative and equal to one ($T_{PH} = 1$). The pulse ratio is not less than 0.5. The examples of such pulse sequences for input signals x_1 and x_2 corresponding the numbers n_1 and n_2 are presented in Fig. 4a and 4b. Table 1 also presents the charging-discharging time constants for the artificial neural network for different response characteristics. All the parameters having the time dimension are expressed as relative pulse widths.

The supplied pulsed signals (Fig. 4a and Fig. 4b) are weighted by the corresponding weights $w_1 = w_2 = 0.5$ and summed to find the average. This way the inner-cellular tension is obtained and then it is compared to adaptive threshold. Fig. 4c presents the adaptive threshold and inner-cellular tension when the time scale is magnified. The pulse is sprung out at the output when the inner-cellular tension is higher than threshold. The latter signal is presented in Fig. 4d.

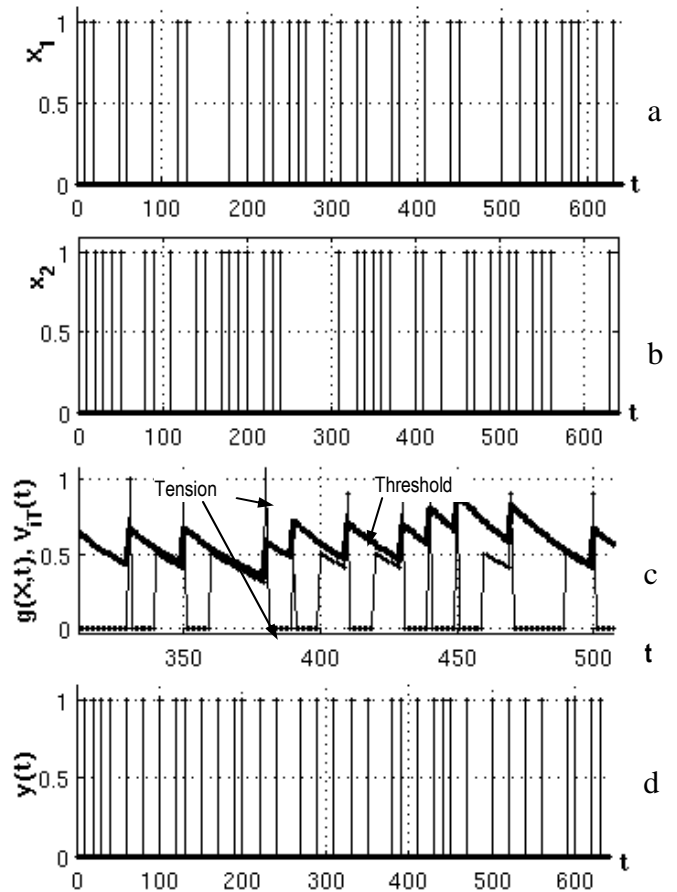

Fig. 4. The input and inner state signals of the artificial neural network: a) input signal representing value 16, b) input signal representing 18 value, c) intra-cellular tension and threshold, d) output signal

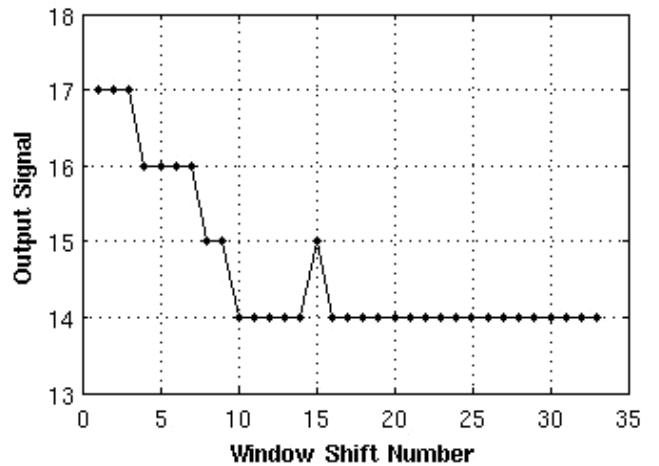

Fig. 5. The quantitative change of the output value while shifting analysis window

The output pulse stream is analyzed by pulse sequence analyzer which counts the pulses during the time window determined by the product of the shortest pause between pulses and system dynamic range. For example, let's assume $T_{PH} = 1$ the pulse width, the minimal time between two pulses is 9 and dynamic range is 32, then the time window for analysis will be 320 sections on the time scale.

The beginning of the next analysis window is shifted right by one shortest period between pulses. Fig. 5 presents the example of how the output value is changing while moving analysis window.

The work of the pulsed artificial neural network is tested by giving into the inputs the pulse sequences which corresponding values differ by 2. In such case, it is easy to check whether the artificial neuron calculates the average and at the same time, the error transfer function depending on input value is obtained. Such steps were repeated 31 times to obtain sufficient information for mean and deviation of the error ε . The error functions of such simple network for the linear and exponential responses $h(\tau, t)$ are presented in Fig. 6a and 6b.

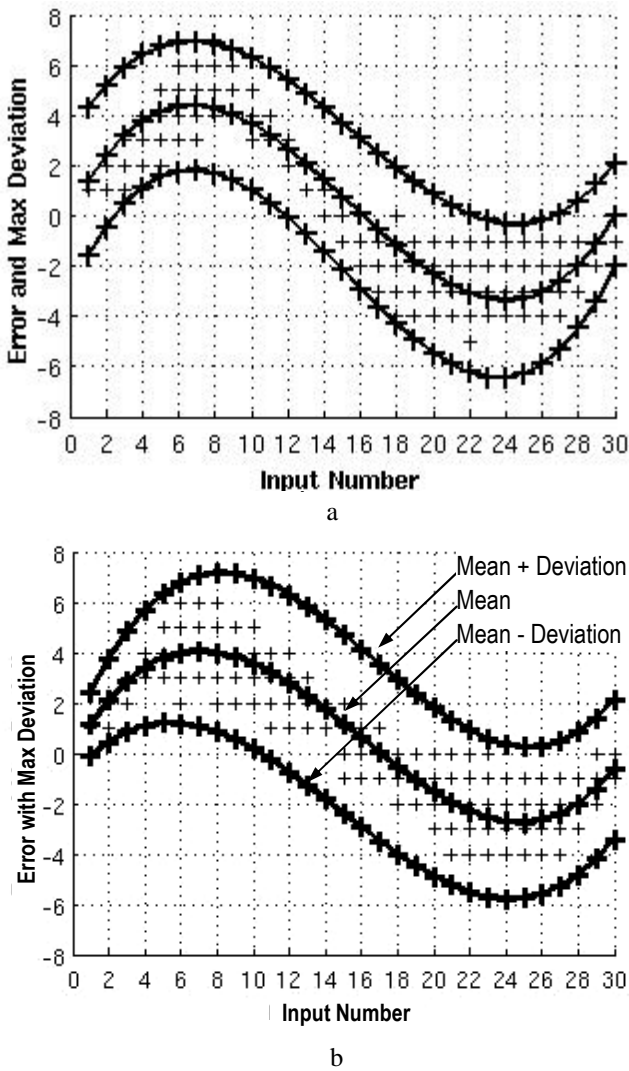

Fig. 6. The error introduced by artificial neural network when response is: a – linear, b – exponential

The swinging character of the error function is shaped by the introduced negative feedback. It controls the tendency to pass the pulse count as constant as possible. It is clear, that when there are no pulses there should be no output pulses and the error function should be somewhere around zero. The same it could be stated for the strong signal because the artificial neuron cannot give more pulses

in its nature. The error in the centre of the dynamic range is also around zero of the optimal shooting response. The greatest error is achieved where neuron tends to increase (in the end of the first quarter) or to decrease (in the end of the third quarter) the quantity of shooting pulses to keep the optimal data rate.

Furthermore, the error characteristics were analyzed to find the quantitative value of systematic error. By trying different level of polynomial, it appeared enough to approximate the error average of the artificial neural network by the third order polynomial sum:

$$\varepsilon(N) = a_0 + a_1N + a_2N^2 + a_3N^3, \quad (11)$$

where N – number or value corresponding input number.

Fig. 7 presents the dependency of bias component a_0 of error of the pulsed neural network when changing the discharge time constant τ_2 (tau₂) for exponential and decrement (discharge speed) for linear response characteristic. Such plots made easy to find the equal conditions for the quantitative comparison of the performance of such networks. When the experimental setup was run for 30 times with the values giving minimal error, the average and standard deviation could be estimated for each factor in the (11) equation. The obtained values are presented in the Table 2. It may be concluded that the pulsed neural network with the exponential response characteristic is performing better than the linear one, especially in the means of bias component's a_0 average and deviation. On the other hand, mean values mostly vote for exponential and deviation values for linear response. Furthermore, it can be concluded that a_0 will give systemically maximum 2% error which is acceptable for speedy vision applications.

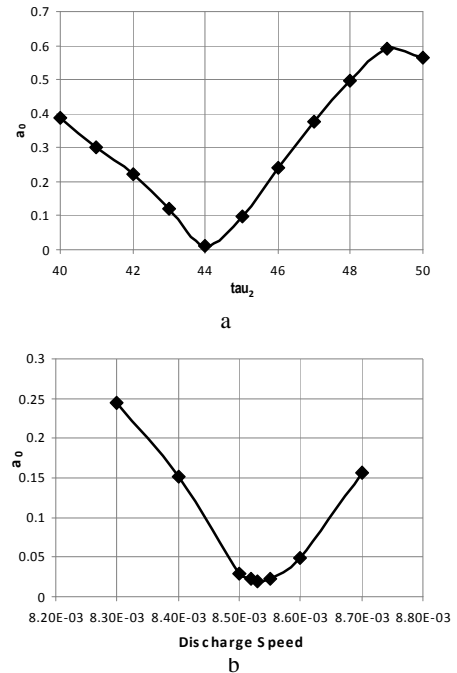
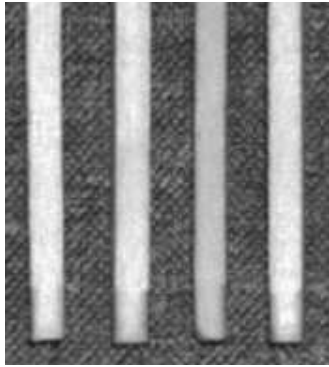

Fig. 7. Error of pulsed neuron depending on: a) threshold decrease time constant for exponential response, b) threshold decrease for linear response

Table 2. The components of the error polynomial of the pulsed artificial network optimized for minimal a_0

	a_0	a_1	a_2	a_3
Average				
Linear	9,17e-3	1.445	-1.38e-1	3.0e-3
Exponential	-3.31e-3	1,269	-1.16e-1	2.4e-3
Standard Deviation				
Linear	7,18e-2	2.04e-2	1.74e-3	4.5e-5
Exponential	5.80e-2	2.36e-2	1.99e-3	4.5e-5



a

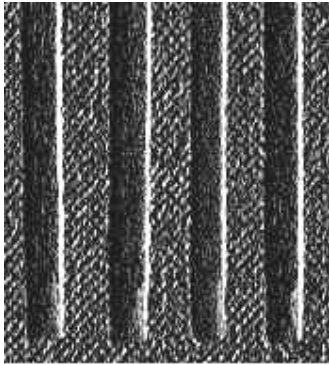

b

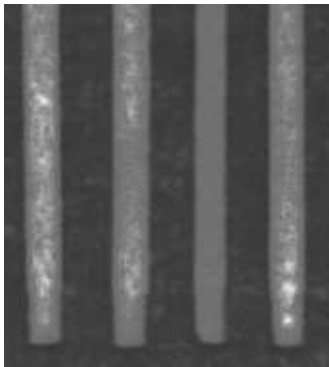

c

Fig. 8. Images processed by pulsed neural network: a) initial image, b) unidirectional gradient 2x2 image, c) locally integrated image by 4x4 size operator

The pulsed neurons were practically applied on images to test the validity of application of such approaches. Fig. 8a presents the source image applied to the similar setup and 8b presents source image processed by unidirectional gradient extraction operator of size 2 by 2 elements. In this case, the pulsed neural network weights conform to unidirectional horizontal gradient and have values:

$$\mathbf{W} = \begin{pmatrix} 1/4 & -1/4 \\ 1/4 & -1/4 \end{pmatrix}. \quad (12)$$

Fig. 8c presents the resulting image after passing the source image through the pulsed neural network performing 4x4 elements integration by giving the weights:

$$\mathbf{W} = \begin{pmatrix} 1/16 & \dots & 1/16 \\ \vdots & \ddots & \vdots \\ 1/16 & \dots & 1/16 \end{pmatrix}. \quad (13)$$

Unidirectional gradient extraction operator (12) makes distinct the vertical parts of the image. In this case, the image is brighter where the lightness of the image goes from the light to dark and vice versa, the image is darker where the lightness of the image goes from dark to light (Fig. 8b). Integration operator, on the contrary to gradient operator, blurs the image. In this case, 8c shows the small details blurred. So, such pulsed artificial neural network may be successfully applied to the widespread convolution in the image processing applications.

Conclusions and Results

The integral error for artificial pulsed neural network is quantitatively less for exponential transfer function than linear in this experiment. But for speed optimized vision systems both approaches are valid and will give maximally 2% error.

The shape of error function of such artificial pulsed neural network is determined by the negative feedback which practically tends to keep the output pulse rate at some optimal value.

The output value of the artificial pulsed neuron settles in some multiples of the minimum pause between pulses, so the output result delay is some periods.

The performance of the pulsed neural network was successfully tested on images convoluting between input signal and simple operators. Such artificial pulsed neural network is suitable for image processing applications.

References

1. **Leon O. Chua, Lin Yang.** Cellular Neural Networks // IEEE International Symposium on Circuits and Systems. – 1988. – Vol. 2. – P. 985–988.
2. **Roggen A. et al.** Hardware Spiking Neural Network with Run-time Reconfigurable Connectivity in an Autonomous Robot // NASA/DoD Conference on Evolvable Hardware (EH'03). – 2003. – P. 199.
3. **Paukštaitis V., Dosinas A.** Multilayer Transformation of Different Resolution for Colour Image Analysis and Segmentation // Electronics and Electrical Engineering. – Kaunas: Technologija, 2006. – No. 8(72). – P. 49–54.
4. **Matolin D. et al.** An Analog VLSI Pulsed Neural Network Implementation for Image Segmentation // Proceedings of the International Conference on Parallel Computing in Electrical Engineering. – 2004. – P. 51–55.

Received 2009 03 12

V. Paukštaitis, A. Dosinas. Pulsed Neural Networks for Image Processing // Electronics and Electrical Engineering. – Kaunas: Technologija, 2009. – No. 7(95). – P. 15–20.

The information streams model of the artificial pulsed neural network to research the performance peculiarities in the up-coming physical systems in the vision applications шы зкуыутеув. The information is transmitted between layers of neurons, performing the convolution, by sequences consisting of pulses of the identical amplitude and width. The simplified theoretical model is tested by the system capable to change the inner and outer performance parameters of the pulsed neuron. The presented model of pulsed network tends to output optimal count of pulses due to negative feedback, which introduces the swinging character of the error function. The paper also presents the quantitative evaluation obtained near minimal error when the pulsed neuron has the response linear and exponential characteristics. The work of both neurons are compared by the extracted factors of the polynomial sum. Therefore, the images were convolved with artificial neural network consisting of the optimized pulse neurons. III. 8, bibl. 4 (in English; summaries in English, Russian and Lithuanian).

В. Паукштайтис, А. Досинас. Импульсные нейронные сети для обработки изображений // Электроника и электротехника. – Каунас: Технология, 2009. – № 7(95). – С. 15–20.

Представлена модель информационных потоков в ячейках импульсных искусственных нейронов, предназначенных для обработки изображений, исследуются особенности работы нейронных сетей такого типа в возможных физических реализациях. Информация между слоями импульсной нейронной сети, реализующей операцию свертки, передается последовательностями импульсов одинаковой амплитуды и одинаковой длительности. Упрощенная теоретическая модель такой сети проверяется системой, способной определить внутренние и внешние параметры работы импульсной нейронной ячейки. Внутренняя отрицательная обратная связь, благодаря которой нейронная ячейка формирует оптимальное число импульсов на выходе, вносит ошибку колеблющегося характера. В работе также приводятся полученные численные оценки для импульсных нейронных ячеек с линейной и с экспонентной передаточной характеристикой, полученные в условиях минимальной ошибки. Работа обеих типов нейронных ячеек оценивается коэффициентами полиномов, аппроксимирующих ошибки. Искусственная нейронная сеть, составленная из таких оптимизированных импульсных нейронных ячеек, испытана для выполнения операций свертки при обработке реальных изображений. Ил. 8, библи. 4 (на английском языке; рефераты на английском, русском и литовском яз.).

V. Paukštaitis, A. Dosinas. Vaizdų apdorojimas impulsiniais neuroniniais tinklais // Elektronika ir elektrotechnika. – Kaunas: Technologija, 2009. – Nr. 7(95). – P. 15-20.

Aprašomas dirbtinio impulsinio neurono ląstelių, taikomų vaizdams apdoroti, informacinio srauto modelis; nagrinėjamos tokio tipo neuroninių tinklų darbo ypatybės galimose fiziniuose realizacijose. Informacija tarp dirbtinio impulsinio neuroninio tinklo sluoksnių, atliekančių sąsūkos operaciją, perduodama sekomis, sudarytomis iš vienodos amplitudės ir vienodos trukmės impulsų. Supaprastintas tokio tinklo teorinis modelis tikrinamas sistema, gebančia nustatyti impulsinio neurono išorinius ir vidinius darbo parametrus. Vidinis dirbtinio impulsinio neurono neigiamas grįžtamasis ryšys, kuris įgalina neuroną formuoti optimalų išėjimo impulsų skaičių, sukelia svyruojamo pobūdžio klaidą. Pristatomi impulsinio neurono su tiesine bei eksponentine perėjimo charakteristikomis darbo kiekybiniai įverčiai, gauti minimalios klaidos sąlygomis. Abiejų tipų neuronų darbas įvertinamas palyginant klaidų, aproksimuotų polinomis, koeficientus. Dirbtinis neuroninis tinklas, sudarytas iš tokių optimizuotų neuronų, išbandytas atliekant sąsūkos operacijas vaizdams apdoroti. II. 8, bibl. 4 (anglų kalba; santraukos anglų, rusų ir lietuvių k.).

DOI: 10.5755/j02.eie.9989