

Investigation of Asymmetric PI Controller using Hardware-in-the-loop Simulation System

V. Zlosnikas, A. Baskys, V. Gobis

*Microelectronics laboratory, Semiconductor Physics Institute,
 A. Gostauto str. 11, LT- 01108 Vilnius, Lithuania, phone: +370 5 2613989; e-mail: mel@pfi.lt*

Introduction

There are lot of processes with the dynamics, which is different during the rise and decay of process parameter. They are called processes (plants) with asymmetric dynamics [1]. Such processes are found in industry, e.g. in water supply and ventilation systems [2], and medicine [3]. The parameters of transfer function of process with the asymmetric dynamics change when the sign of the process parameter time derivative changes. Because of this, the popular in industry PID and PI controllers with the constant parameters do not allow us to achieve good transient performance of the feedback control system of such processes. It is efficient to employ the asymmetric controllers in such a situation [4]. The main feature of these controllers is that their parameters are changed when changes the sign of control error or sign of process parameter time derivative. This allows us to use the different values of controller parameters during the rise and decay of process parameter. The employment of asymmetric controllers as compared to PID and PI controllers allows improving the feedback control quality of processes with the asymmetric dynamics.

The developed control algorithm and designed digital asymmetric Proportional-Integral (aPI) controller, the investigation technique of controller using hardware-in-the-loop (HIL) simulation system based on the basis of multifunctional PC board PCI-6024E and software Simulink and obtained investigation results have been presented in this work. The multifunctional PC board PCI-6024E implements the link between the actual aPI controller and virtual asymmetric process implemented using software Simulink. The controller is developed and designed in Microelectronics Laboratory, Semiconductor Physics Institute. It is employed for control of air pressure of advanced energy-saving industrial ventilation systems.

Asymmetric PI controller

The developed digital aPI controller realizes algorithm

$$\left\{ \begin{array}{l} U(t) = K_p(t) e(t) + \int_{t_0}^t \frac{K_p(\tau)}{T_i(\tau)} e(\tau) d\tau, \\ K_p(t) = K_{pp}, T_i(t) = T_{ip} \mid e(t) \geq 0, \\ K_p(t) = K_{pn}, T_i(t) = T_{in} \mid e(t) < 0, \end{array} \right. \quad (1)$$

where $U(t)$ – the controller output, $K_p(t)$ – the proportional constant, t – time, $e(t)$ – the error (difference between desired and actual values of controlled process parameter), $T_i(t)$ – integration time, K_{pp} , T_{ip} and K_{pn} , T_{in} – proportional constant and integration time that act at positive and negative $e(t)$, respectively, t_0 – point in time at which the algorithm starts to operate.

It is seen from (1) that the different values of controller parameters $K_p(t)$ and $T_i(t)$ are used at positive and negative $e(t)$ values. The parameter of controlled process is usually increased if $e(t)$ is positive and decreased if it is negative. Therefore, the sign of $e(t)$ is convenient indicator for estimation of the control system state and the parameters of controller should be switched at instants when the sign of $e(t)$ changes.

The block diagram of digital aPI controller is presented in Fig. 1. The *Zero-Order Hold* block provides the sampling of $e(t)$ signal, which is the input signal of controller. The blocks K_{pp} , $1/T_{ip}$ set the parameters of controller for case when $e(t) \geq 0$, and K_{pn} , $1/T_{in}$ – when $e(t) < 0$. Switches *Sw1* and *Sw2* provide the commutation of parameters. The *Discrete-Time Integrator* performs the numerical integration action. Additionally, this block provides the limitation of integration result, i.e. it provides so-called anti windup function [5].

The controller is designed on the basis of microcontroller AT89C51AC3. It is intended for use in industrial ventilation systems and is employed for feedback control of rotation velocity of fans with standard (0-10) V feedback signal. The values of controller parameters K_{pp} and K_{pn} can be preset in range 0.1 to 10.0, the values of T_{ip} , T_{in} – in range 2 to 180 seconds. The controller is designed to use with the frequency converter, which supplies the AC induction motor of fan drive with variable frequency variable amplitude voltage [6]. The controller output signal

$U(t)$ is used to control the frequency of output voltage of the frequency converter and, as a consequence, the rotation speed of motor.

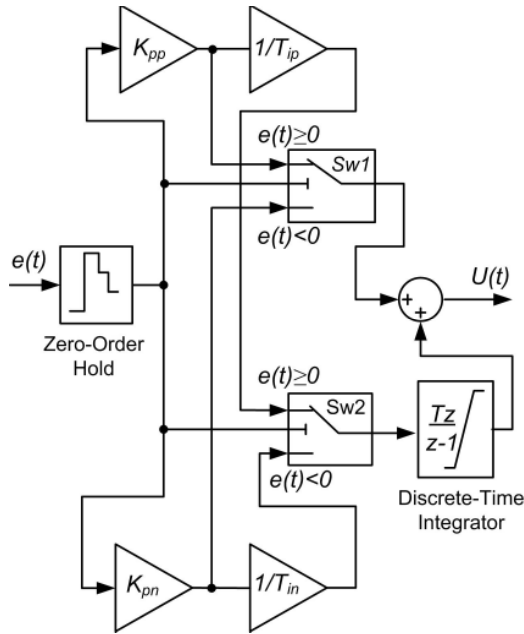

Fig. 1. The block diagram of digital aPI controller

The hardware-in-the-loop simulation system

The operation of the designed actual aPI controller should be investigated in various actual ventilation systems with various dynamics. However, this is complicated and long-lasting procedure. It is much more convenient, especially during the early stages of development, to use the models of controlled processes for controller.

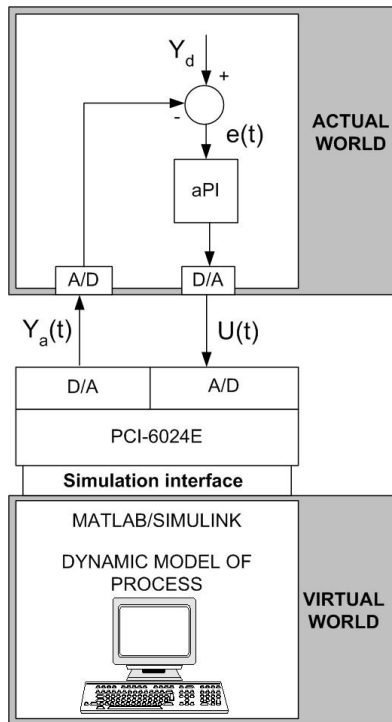

Fig. 2. The block diagram of the HIL simulation system for the investigation of aPI controller

investigation. The application of so-called HIL simulation system is the most advanced solution of this problem. The multifunctional PC board PCI-6024E has been employed for this purpose. It allows interfacing of models created using dynamic system simulation software Simulink with the actual equipments using analogue signals. In our situation – interfacing of the dynamic models of controlled ventilation system processes with the developed actual aPI controller.

The structure of the HIL simulation system for the investigation of aPI controller is presented in Fig.2. The A/D and D/A converters of aPI controller and multifunctional PC board PCI-6024E are employed for the interfacing using analogue signals (voltage in range 0-10 V).

Model of processes with the asymmetric dynamics

The dynamics of most processes (plants) in industry including industrial ventilation systems usually are presented by the transfer function, which has following general form [7]:

$$G_p(s) = \frac{e^{-Ls}}{(\tau s + 1)^m}, \quad (2)$$

where L – transportation lag, τ – time constant, m – order of transfer function (order of the controlled process) and s – the Laplace variable. The experimental investigation of plants with the asymmetric dynamics shows that asymmetry of the dynamics can be taken into account by switching of τ value in the transfer function at the instants when the controlled process parameter time derivative $dY_a(t)/dt$ changes the sign. Therefore, the transfer function of such process can be presented as follows:

$$G_{pa}(s) = \frac{e^{-Ls}}{(\tau s + 1)^m}, \quad \tau = \begin{cases} \tau_p, & dY_a(t)/dt \geq 0, \\ \tau_n, & dY_a(t)/dt < 0, \end{cases} \quad (3)$$

where τ_p and τ_n – the process time constant values that act during the rise and decay of process parameter, respectively.

The simulation of the process, which in the general case is presented by the transfer function (3), using a standard transfer function block of the commonly accepted software Simulink is complicated. It may appear that the value of τ could be switched by employment of the network that contains two transfer function blocks with different τ values (two transfer function blocks with the inputs connected up and with a switch on the outputs). However, this way of problem solution is not correct [4]. The reason is that switching of outputs of transfer function blocks in such a situation can cause the jumps of simulated process parameter $Y_a(t)$, which in fact do not exist.

Authors of this work have developed the model of 1-st order process with the asymmetric dynamics for the software Simulink presented in Fig. 3, which allows us to avoid the shortcomings mentioned above. The block diagram of the model includes integrator block $1/s$, two gain blocks $1/\tau_p$ and $1/\tau_n$, switch block Sw and sum block. It is easy to check that the transfer function of process model presented in Fig. 3 is $1/(\tau_p s + 1)$ at $dY_a(t)/dt \geq 0$ and $1/(\tau_n s + 1)$

at $dY_a(t)/dt < 0$. The value of τ can be changed by switching of gain blocks, which stay before the integrator, therefore the response of model transient is smooth and it corresponds to the transient of actual processes with the asymmetric dynamics.

The transfer function of process with the asymmetric dynamics for the general case (3) can be realized using model presented in Fig. 4. It includes m 1-st order process model blocks (Fig. 3) connected in series and derivative block $dY_a(t)/dt$, which checks the derivative of process parameter and controls the switches Sw . Additionally, it includes the transport delay block e^{-Ls} , which delays the response by L .

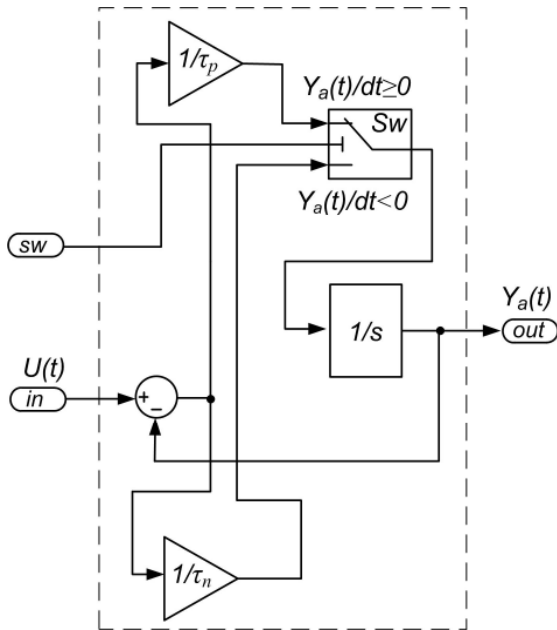

Fig. 3. The model of 1-st orders process with the asymmetric dynamics for the software Simulink

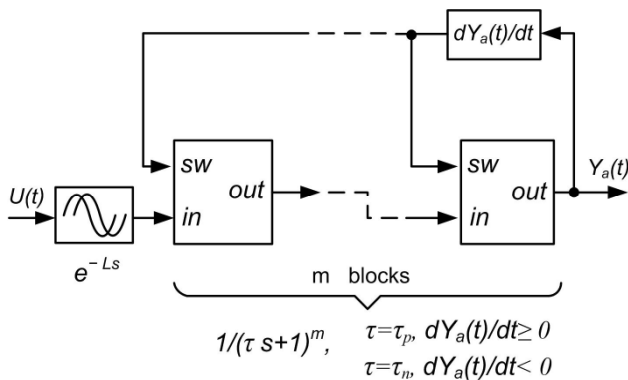

Fig. 4. The model of the m -order process with the asymmetric dynamics and response delay for the software Simulink

Investigation of asymmetric PI controller

The designed digital aPI controller was investigated using the investigation system based on the HIL simulation system (Fig. 2). The picture of the system is presented in Fig. 5. The controlled process with the asymmetric dynamics was simulated using developed model presented in Fig. 4.

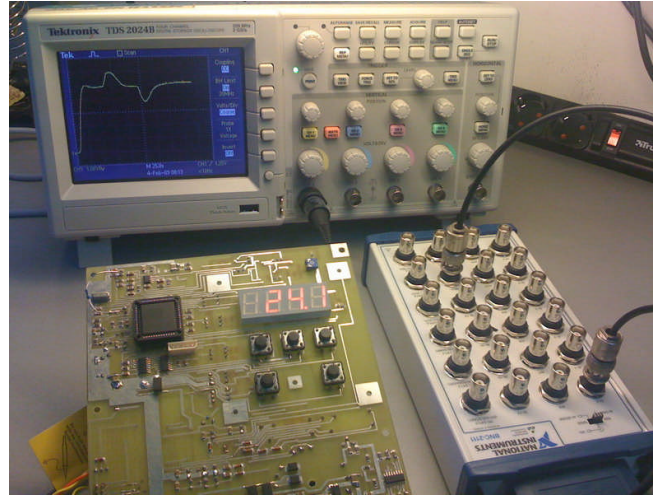

Fig. 5. The HIL simulation system for the investigation of aPI controller (the aPI controller is on the left, the connector block of multifunctional PC board PCI-6024E, which is connected to the PC with the installed Simulink software– on the right)

The investigation was provided for the process presented by the transfer function (3) with parameters $L=1$, $m=2$, $\tau_p=2$ and $\tau_n=0.2$, which corresponds to the actual industrial ventilation system air pressure dynamics. The set point pulse and load disturbance response of control system of such a process have been investigated. The obtained results are presented in Fig. 6. They are compared with the results when the PI controller is used.

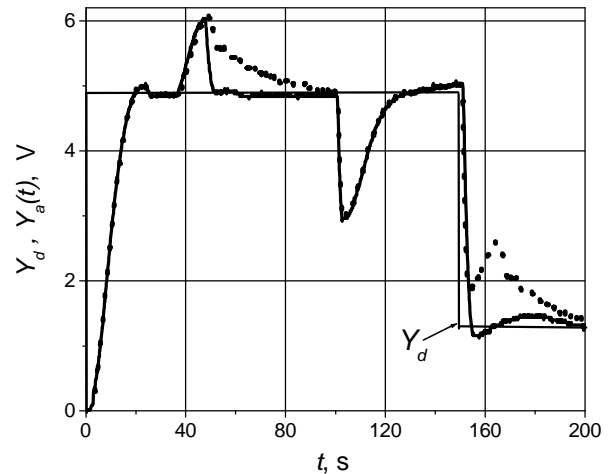

Fig. 6. Set point pulse and load disturbance response of the control system based on the aPI (solid line) and PI (dotted line) controllers. The PI controller parameters ($K_p=0.8$, $T_i=10s$) are adjusted to dynamics of the process, which corresponds to the rise of controlled parameter. Parameters of aPI controller: $K_{pp}=0.8$, $K_{pn}=0.5$, $T_{ip}=10s$, $T_{in}=2s$

It is seen (Fig. 6) that designed digital aPI controller, which realizes the proposed algorithm (1), allows us to improve the feedback control quality of analyzed process with the asymmetric dynamics as compared with the case when popular in industry PI controller is used.

Conclusions

The proposed control algorithm for control of processes with the asymmetric dynamics, which is employed in the designed digital aPI controller, enables using the different values of controller parameters during the rise and decay of controlled process parameter.

The developed model of process with the asymmetric dynamics allows us to achieve smooth transient of model response, which corresponds to the transient of actual processes.

The employed HIL simulation system enables us to investigate the operation of designed actual controller using proposed model of controlled process with the asymmetric dynamics and software Simulink.

The designed digital aPI controller allows us to improve the feedback control quality of analyzed process with the asymmetric dynamics as compared with the case when popular in industry PI controller is used.

Acknowledgements

This work was supported by the Lithuanian State Science and Studies Foundation under High-tech development program project B -13/2007–2009.

References

1. **Zlosnikas V., Baskys A.** Integral Controller for the Plants with the Asymmetric Dynamics // *Electronics and Electrical Engineering*. – Kaunas: Technologija, 2008. – No. 1(81). – P. 15–18.
2. **Lipnickas A., Jankauskaite R., Zukauskas V., Kubilius V.** Laboratory Stand for Air Flow Stabilization // *Solid State Phenomena*. – 2006. – Vol. 113. – P. 119–124.
3. **Gantt J. A., Rochelle K. A., Gatzke E. P.** Type I diabetic patient insulin delivery using asymmetric PI control // *AICHE Annual Meeting*. – 2004. – P. 1–7.
4. **Baskys A., Zlosnikas V.** Asymmetric PID controller // *Proceedings of the 32nd IEEE Industrial electronics conference IECON 06*. – Paris. – 2006. – P. 219–223.
5. **Franklin G., Powell J. D., Emami-Naeini A.** *Feedback Control of Dynamic Systems*. – New York: Prentice Hall, 2005.
6. **Rinkeviciene R., Batkauskas V.** Modeling and Investigation of Vector Controlled Induction Drive // *Electronics and Electrical Engineering*. – Kaunas: Technologija, 2008. – No. 1(81). – P. 53–56.
7. **Kristiansson B., Lennartson B.** Robust and optimal tuning of PI and PID controller // *IEE Proc. – Control Theory Appl.* – 2002. – Vol. 149, No. 1. – P. 17–25.

Received 2009 02 12

V. Zlosnikas, A. Baskys, V. Gobis. Investigation of Asymmetric PI Controller using Hardware-in-the-loop Simulation System // Electronics and Electrical Engineering. – Kaunas: Technologija, 2009. – No. 7(95). – P. 7–10.

The algorithm for control of processes with the asymmetric dynamics, which is employed in the designed digital asymmetric PI (aPI) controller, has been proposed. The investigation technique of designed aPI controller using hardware-in-the-loop (HIL) simulation system and software Simulink have been presented. The special-purpose multifunctional PC board, which includes the A/D and D/A converters, implements the link between the actual aPI controller and virtual asymmetric process realized using software Simulink and developed model of process with the asymmetric dynamics. The controller is based on the microcontroller AT89C51AC3. It is intended to use for the feedback control of air pressure of advanced energy-saving industrial ventilation systems. The designed aPI controller allows us to improve the control quality of analyzed concrete process with the asymmetric dynamics as compared with the case when popular in industry PI controller is used. Ill. 6, bibl. 7 (in English; summaries in English, Russian and Lithuanian).

V. Злосникас, А. Башкис, В. Гобис. Исследование асимметричного ПИ регулятора, применяя НПЛ–модель // Электроника и электротехника. – Каунас: Технологія, 2009. – № 7(95). – С. 7–10.

Предложен алгоритм управления для процессов с асимметричной динамикой, который применён в разработанном цифровом асимметричном ПИ (аПИ) регуляторе. Представлена методика исследования аПИ регулятора с применением НПЛ–модели, которая основана на применении специальной АЦП/ЦАП карты для персонального компьютера и программы динамического моделирования Simulink. АЦП/ЦАП карта позволяет поддерживать связь между реальным регулятором и виртуальным процессом, реализованном при помощи программы Simulink и разработанной модели процесса с асимметричной динамикой. Предлагаемый аПИ регулятор создан на основе микроконтроллера AT89C51AC3. Он предназначен для управления давлением воздуха в современной, энергосберегающей, промышленной системе вентилирования. Разработанный аПИ регулятор, по сравнению с широко применяемым в промышленности ПИ регулятором, позволяет улучшить качество управления конкретного процесса с асимметричной динамикой, который исследован в работе. Ил. 6, библи. 7 (на английском языке; рефераты на английском, русском и литовском яз.).

V. Zlosnikas, A. Baškys, V. Gobis. Asimetrinio PI regulatoriaus tyrimas HIL modeliavimo sistema // Elektronika ir elektrotechnika. – Kaunas: Technologija, 2009. – Nr. 7(95). – P. 7–10.

Pasiūlytas asimetrinės dinamikos procesų valdymo algoritmas. Jis panaudotas sukurtame skaitmeniniame asimetriniame PI (aPI) reguliatoriuje. Pateikta aPI reguliatoriaus tyrimo, naudojant HIL modeliavimo sistemą, metodika. Ji realizuojama naudojant specialią ASK/SAK kompiuterio kortą ir dinamių procesų modeliavimo programą „Simuliuok“. ASK/SAK kompiuterio korta palaiko ryšį tarp realaus aPI reguliatoriaus ir virtualaus proceso su asimetrine dinamika, realizuoto naudojant sukurtą proceso modelį ir programą „Simuliuok“. Regulatorius suprojektuotas naudojant mikrovaldiklį AT89C51AC3. Sukurtas aPI reguliatorius, skirtas modernių, energiją tausojančių industrinių vėdinimo sistemų oro slėgiui valdyti. Palyginti su plačiai pramonėje naudojamu PI reguliatoriumi, jis leidžia pasiekti geresnę analizuoto asimetrinės dinamikos proceso valdymo kokybę. Il. 6, bibl. 7 (anglų kalba; santraukos anglų, rusų ir lietuvių k.).

DOI: 10.5755/j02.eie.9987