

## Adaptive Level–Crossing Sampling Based DSP Systems

A. Baums, M. Greitans, U. Grunde

*Institute of Electronics and Computer Science*

*Dzerbenes st. 14, LV–1006, Riga, Latvia, phone: +371 6755813, e–mail: baum@edi.lv*

### Introduction

Wireless sensor networks (WSN) are effective tool for data acquisition and processing. Adaptive sampling is widely used in WSN [1] to provide energy–efficient data acquisition. Usually adaptive sensor sampling scheme supports some adaptive sampling algorithms. The algorithms modify sampling rate either controlling sampling frequency or letting sensors to skip sampling. Further energy savings in a WSN sensor node may be achieved by adding some digital signal processing (DSP) capabilities to the sensor node. That decreases the amount of transmitted data and saves energy because the primary source of energy consumption in the sensor node is the operation of the radio transceiver. The implementation of adaptive level–crossing (LC) sampling based DSP system is a solution for the energy–efficient data acquisition, and for the decrease of collected data. LC sampling method is chosen due to its built–in capability to adapt to the speed of signal changes instead of controlling sampling rate.

Recently several applications of non–conventional processing DSP systems [2–4] that are using non–uniform analog–to–digital converters (ADC) based on LC sampling are proposed. Unlike the uniform sampling method, LC sampling compares the signal with a set of reference levels and samples the time interval during the moments when the signal crosses predetermined reference levels. In certain applications that results in decreased number of data to compare with uniform sampling and allows use of DSP system resources only when it is necessary [4]. Adaptive LC sampling based DSP system is different from DSP systems mentioned above by using reference levels that are adaptively spaced to an input signal in order to use the decreased number of reference levels. Such a DSP system may be used for acquisition and pre–processing of non–stationary [5] and non–linear signals, which are localized in time.

### Adaptive level–crossing sampling

Usually LC sampling methods [6, 7] are used in non–adaptive way. They assume that a difference between two subsequent reference level values is fixed and reference

levels are spaced equidistantly. Equidistantly spaced reference levels are not adapted to an input signal. This approach requires the high linearity source of reference levels, but simplifies calculations of sampled data. Different approach is an adaptive LC sampling that is using non–uniformly spaced reference levels as is shown in Fig.1. Reference levels  $rl_1 \div rl_4$  are adapted to the input signal by taking into account the signal probability distribution function and the signal power spectral density. Time intervals are sampled during the moments when the input signal  $x(t)$  crosses the predetermined reference level values  $rl_1 \div rl_4$ . They are marked as level–crossing events. The subsequent quantization of the time interval between two consecutive level–crossing events is performed with a clock.

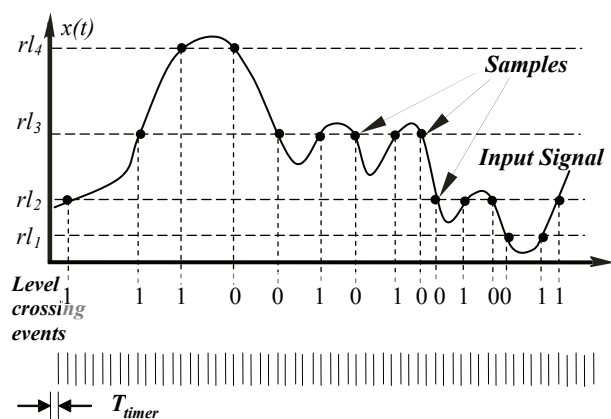

Fig. 1. Adaptive level–crossing sampling

Existing implementations of non–adaptive LC sampling [8, 9] are using different numbers of reference levels. Limited number of reference levels requires their optimal usage. It is shown in [8] that non–uniformly spaced reference levels are more preferable for certain applications. We are expecting that the adaptation of reference levels to the input signal will result in decreased number of levels compare with the number of equidistantly spaced reference levels. Our assumption is that at least two level–crossing events on the signal slope are necessary to obtain fairly accurate reconstructed signal. Number and

spacing of reference levels can vary depending from type of the input signal. That requires the implementation of dedicated control of LC sampling and resources that are able to provide such control.

### Implementation

Recent hardware implementations of LC sampling ADC are presented in [8, 9]. In [10] we offered to use a microprocessor as an ADC controller for LC sampling ADC. An example of such implementation is shown in Fig.2. ADC controller with the microprocessor is programmable. It is easy to implement adaptive LC sampling by spacing reference level values accordingly to the input signal probability distribution function and by changing timer clock frequency to adjust to the required ADC resolution. ADC controller is testing the outputs of comparators CMP1, CMP2 and reloading digital-to-analog converters DAC1, DAC2. Unlike [9] DAC1 and DAC2 outputs may be non-linear. Depending from the type of signal ADC controller allows use of several subsets of reference levels that are adapted to the specific signal.

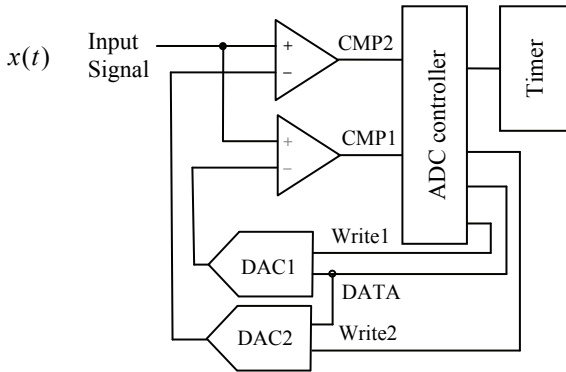

Fig. 2. Adaptive LC sampling scheme implementation

The performance of this architecture is limited by the value of the maximum loop delay  $\delta_{\max}$ . It determines how fast the loop delivers output changes of CMP1 and CMP2 to the inputs of CMP1 and CMP2.  $\delta_{\max}$  is total of delays of ADC controller, DAC and CMP. For correct operation of non-adaptive sampling  $\delta_{\max}$  should satisfy condition:

$$\delta_{\max} < 1/(2\pi f_{\max} N), \quad (1)$$

where  $N$  – the number of sampling levels;  $f_{\max}$  – the maximum input signal  $x(t)$  frequency. At given  $\delta_{\max}$  increase of  $N$  leads to the decrease of the bandwidth of the input signal  $x(t)$  that can be sampled. To satisfy (1) a compromise between  $N$  and  $f_{\max}$  should be find. In case of adaptive sampling  $\delta_{\max}$  should satisfy condition :

$$\delta_{\max} < 1/(2\pi f_{\max} M), \quad (2)$$

where  $M$  is the calculated number of sampling levels for the smallest used quantization step. Because of  $M > N$  frequency limitations for adaptive LC sampling are stronger.

As shown in [9] the ADC resolution based on no-

adaptive LC sampling scheme is determined with effective number of bits (ENOB) that includes the hardware resolution  $L$

$$L = \log_2 N \quad (3)$$

and the timer clock resolution.

The finite resolution of the timer clock introduces quantization noise in time. According to [6] the quantization noise depends on the input signal amplitude and the resolution ratio  $R$  :

$$R = f_{\text{timer}} / f_{\text{signal}}, \quad (4)$$

where  $f_{\text{timer}}$  – a timer clock frequency;  $f_{\text{signal}}$  – a signal frequency. For a sinusoidal signal the signal-to-noise ratio (SNR) is independent of the signal amplitude and proportional only to the resolution ratio

$$\text{SNR} = 20 \log R - 11.2 \text{dB}. \quad (5)$$

This means that doubling of the timer clock frequency  $f_{\text{timer}}$  results in an increase in SNR by one effective bit [6]. ADC resolution for adaptive LC sampling is defined similarly to ADC resolution for non-adaptive LC sampling.

The reconstruction of the sampled signal is using interpolation procedure and that can limit the maximal achievable resolution. In order to evaluate the impact of the interpolation procedure to the reconstruction of the sampled signal several LC sampling schemes are simulated with different number of reference levels  $N$  using uniformly and non-uniformly spaced reference levels.

### Simulation

Simulation of the non-adaptive and adaptive LC sampling that is shown in Fig.3 and in Fig. 4 is performed to evaluate the quality of the sampled signal after reconstruction and to estimate feasible values of reference levels  $N$ .

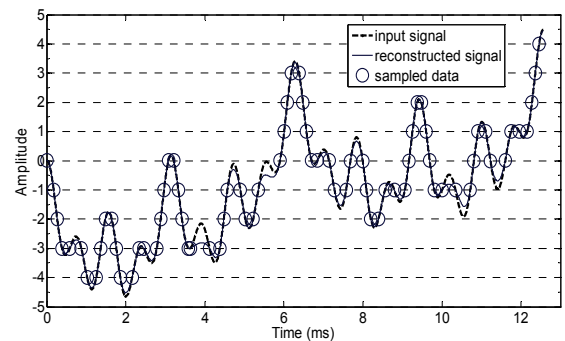
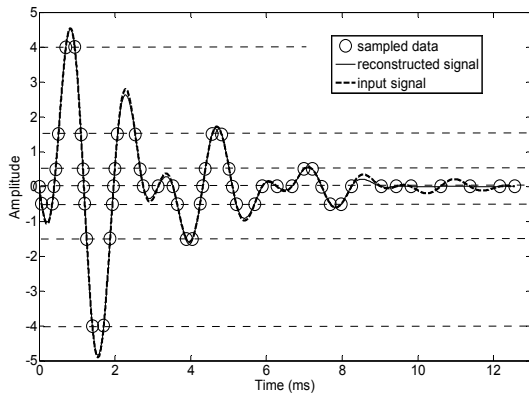

Fig. 3. Non-adaptive LC sampling and reconstruction of signal Test1

Two signals Test1 and Test2 were sampled using both methods of LC sampling. Afterwards LC sampling signals Test1 and Test2 were reconstructed using sampled data and MatLab cubic spline data interpolation function. The reconstructed signals were analyzed using the empirical mode decomposition (EMD) to evaluate the

quality of the signal LC sampling for both sampling methods.



**Fig. 4.** Adaptive LC sampling and reconstruction of signal Test2

The EMD is proposed by Huang et al. as a new signal decomposition method for nonlinear and non-stationary signals [11]. It is used as an alternative to traditional time–frequency analysis methods. The EMD decomposes a signal into a collection of oscillatory modes, called intrinsic mode functions (IMF), which represent fast to slow oscillations in the signal. We are using the EMD based routine *rParabEmd* [12] that performs the EMD accordingly to the paper [13]. Fig. 5 presents the EMD of the reconstructed signal Test2 that shows two decaying oscillations and some residue value.

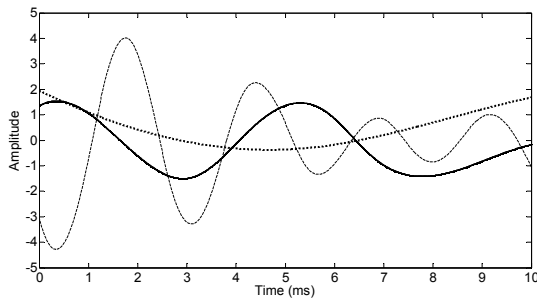

**Fig. 5.** Empirical mode decomposition of reconstructed signal Test2 for  $N = 9$

The correlation between the input signals and the reconstructed signals as well as the correlation between the EMD of input signals and the EMD of reconstructed signal is used to compare non-adaptive and adaptive LC sampling methods. The calculations of the signal correlation were performed using the expression (6) that represents a MatLab function:

$$R = \text{corrcoef}(x, y), \quad (6)$$

where  $R$  – correlation coefficients;  $x$  – an input;  $y$  – a reconstructed signal.

Table 1 and Table 2 show that correlation between input signals and reconstructed signals is depending from the number of sampling levels  $N$  and the method of LC sampling. With increase of  $N$  the differences of correlation between both LC sampling methods is decreasing. In Table 3 and Table 4 correlation between EMD of input signals and EMD of reconstructed signals

show poor correlation for the non-adaptive LC sampling of the signal Test2. The signal Test2 presents an exponentially decaying signal. Table 1 shows that in the case of non-uniformly spaced reference levels good correlation between an input signal and a reconstructed signal is achievable at 9 reference levels. Comparison of Table 1 with Table 2 shows that quality of the EMD of reconstructed signals essentially depends from the number of levels and their spacing. Reconstructed signals that were sampled using the adaptive spacing of reference levels have better correlation at the small number of reference levels compare to signals that were sampled using uniformly spaced reference levels. It is necessary to notice that use of non-uniformly spaced reference levels requires the knowledge of the input signal properties.

**Table 1.** Correlation between input signals and reconstructed signals for different  $N$  with non-adaptive spacing

N	Test 1	Test 2
5	0.8392	0.9376
7	0.9716	0.9907
9	0.9975	0.9910
13	0.9997	0.9927
16	0.9998	0.9989

**Table 2.** Correlation between input signals and reconstructed signals for different  $N$  with adaptive spacing

N	Test 1	Test 2
5	0.9735	0.9974
7	0.9937	0.9988
9	0.9991	0.9992
13	0.9999	1.0000
16	1.0000	1.0000

**Table 3.** Correlation between EMD of input signals and EMD of reconstructed signals for different  $N$  with non-adaptive spacing

N	Test 1	Test 2
5	0.7543	0.4161*
7	0.8056	0.8567*
9	0.9957	0.8617*
13	0.9994	0.8478*
16	0.9995	0.9152

\*correlation is for a part of the reconstructed signal

**Table 4.** Correlation between EMD of input signals and EMD of reconstructed signals for different  $N$  with adaptive spacing

N	Test 1	Test 2
5	0.9409	0.8351
7	0.9640	0.9026
9	0.9981	0.9996*
13	0.9999	0.9998
16	1.0000	0.9998

## Conclusions

Adaptive LC sampling ADC with the number of reference levels  $N = 9 - 16$  are demonstrating high correlation between values of input signals and reconstructed signals. The EMD of reconstructed test signals confirms that using non-uniformly spaced reference levels the decomposition of reconstructed signals is improving essentially.

Limiting factors of the system are a complexity of the

methods of the level-sampled signal reconstruction and of the decomposition of reconstructed signals.

## References

1. **Jain A., Chang E. Y.** Adaptive sampling for sensor networks // Proceedings of the 1st Workshop on Data Management for Sensor Networks, DMSN2004. – 2004. – P. 10–16.
2. **Qaisar S. M., Fesquet L., Renaudin M.** Adaptive rate filtering for a signal driven sampling scheme // ICASSP'07. – 2007. – P. 1465–1468.
3. **Li Y. W., Shepard K. L., Tsividis Y. P.** Continuous time Digital Signal Processors // Proceedings of International Symposium on Asynchronous Circuits and Systems ASYNC'05. – 2005. – P. 138 – 145.
4. **Schell B., Tsividis Y.** A clockless ADC/DSP/DAC system with activity-dependent power dissipation and no aliasing // Digest 2008 IEEE ISSCC. – 2008. – P. 550, 551, 635.
5. **Greitans M.** Processing of Non-Stationary Signal Using Level-Crossing Sampling // Proceedings of the International Conference on Signal Processing and Multimedia Applications SIGMAP2006. – 2006. – P. 170–177.
6. **Sayiner N., Sorensen H. N., Viswanathan T. R.** A level-crossing sampling scheme for A/D conversion. // IEEE Trans. Circuits and Systems. – 1996. – No.4(43). – P. 335 – 339.
7. **Allier E., Sicard G., Fesquet L., Renaudin M.** A new class of asynchronous a/d converters based on time quantization // Proceedings of International Symposium on Asynchronous Circuits and Systems ASYNC'03. – 2003. – P. 196–205.
8. **Kozmin K., Johansson J., Delsing J.** A low power, propagation delay stable, continuous-time comparator // Proceedings of the 22nd Norchip Conference IEEE. – 2004. – P. 261–264
9. **Allier E., Goulier J., Sicard G., Dezzani A., André E., Renaudin M.** A 120 nm Low Power Asynchronous ADC // International Symposium on Low Power Electronics and Design ISLPED'05. – 2005. – P. 60–65.
10. **Baums A., Greitans M., Grunde U.** Level-crossing sampling using microprocessor based system // Proceedings of the International Conference on Signals and Electronic Systems ICSES'08 – 2008. – P. 19–23.
11. **Huang N. E., Shen Z., Long S. R., et al.** The empirical mode decomposition and hilbert spectrum for nonlinear and nonstationary time series analysis // Proceedings of the Royal Society. – 1998. – Vol.454. – P. 903–995.
12. Mathematical works. [www.mathworks.com/matlabcentral/fileexchange/21409?controller=file\\_infos&download=true](http://www.mathworks.com/matlabcentral/fileexchange/21409?controller=file_infos&download=true)
13. **Rato, R. T., Ortigueira, M. D., Batista, A. G.** On the HHT, its problems, and some solutions // Mechanical Systems and Signal Processing – 2008. – Vol. 22. – P. 1374–1394.

Received 2009 05 14

### **A. Baums, M. Greitans, U. Grunde. Adaptive Level-Crossing Sampling Based DSP Systems // Electronics and Electrical Engineering. – Kaunas: Technologija, 2009. – No. 8(96). – P. 90–93.**

Adaptive level-crossing sampling based DSP systems are able to provide energy-efficient data acquisition and transmission. The proposed sampling mechanism is a generalization of the sampling with equidistantly spaced reference levels. Two different sampling implementations are offered. Simulation of the adaptive level-crossing sampling is performed to estimate the number of reference levels and evaluate the quality of signal reconstruction. The approach is targeting non-stationary and nonlinear signals using non-conventional digital signal processing methods. High correlation between input and reconstructed signal is supporting use of small number 9–16 sampling levels. Ill. 5, bibl. 13, tabl. 4 (in English; abstracts in English, Russian and Lithuanian).

### **A. Баумс, М. Грейтанс, У. Грунде. Адаптивные DSP системы на основе дискретизации пересечением порога // Электроника и электротехника. – Каунас: Технология, 2009. – № 8(96). – С. 90–93.**

Адаптивные DSP системы на основе дискретизации пересечений порога позволяют проводить энерго-экономичный сбор и сокращают объем передаваемых данных. Предлагаемый метод дискретизации является обобщением метода дискретизации с равномерно расположенными порогами. Проводилось моделирование адаптивной дискретизации пересечением порога для определения числа порогов и для оценки качества восстановленного сигнала. Подход предназначен для обработки нестационарных и нелинейных сигналов с использованием цифровых методов их обработки. Высокая степень корреляции подтверждает достаточность использования 9–16 порогов при дискретизации. Ил. 5, библи. 13, табл. 4 (на английском языке; рефераты на английском, русском и литовском яз.).

### **A. Baums, M. Greitans, U. Grunde. Adaptyviosios skaitmeninių signalų apdorojimo sistemos paremtos atrankine diskretizacija // Elektronika ir elektrotechnika. – Kaunas: Technologija, 2009. – Nr. 8(96). – P. 90–93.**

Aprašyta adaptyvi skaitmeninių signalų apdorojimo sistema, paremta atrankine diskretizacija, kuri leidžia sumažinti perduodamų duomenų srautus. Siūlomas diskretizacijos metodas yra diskretizacijos metodo su tolygiai paskirstytomis programomis sintezė. Atliktas adaptyviosios diskretizacijos modeliavimas, įvertintas ribų susikirtimas, skirtas ribų skaičiui ir atkurto signalo kokybei nustatyti. Šis skaitmeninių signalų apdorojimo metodas skirtas nestacionariems ir netiesiniams signalams. Aukšto lygio koreliacija patvirtina, kad diskretizacijai pakanka 9–16 ribų. Il. 5, bibl. 13, lent. 4 (anglų kalba; santraukos anglų, rusų ir lietuvių k.).

DOI: 10.5755/j02.eie.9969