

Research of the Usage of Double-fed Generators in Wind Turbines

Č. Ramonas, V. Kepalas

*Department of Control Technology, Kaunas University of Technology,
 Studentų str. 48, LT-51367 Kaunas, Lithuania, phone: +370 37 300274, e-mails: ceslovas.ramonas@ktu.lt,
 vytautas.kepalas@ktu.lt*

V. Adomavičius

*The Centre for Renewables Energy Technologies, Kaunas University of Technology,
 Studentų str. 48-329, LT-51367 Kaunas, Lithuania, phone: +370 37 351181; e-mail: vytautas.adomavicius@ktu.lt*

Introduction

Many predictions say that rather soon wind energy will become one of the main sources for power production in global scale [1]. Presently Lithuania has installed only less than 60 MW of cumulative wind turbines' capacity and is lagging behind in comparison with many other countries. Rapid progress of the wind power development in this country restrict local bureaucratic barriers on the way of access to the electric grid, lack of the more favourable legal basis, potential problems of wind origin power balancing and reservation in the power grid, low and moderate wind energy resources in some regions located farther to the east from the seaside, lack of the financial means and some other.

The best wind energy resources are in the Baltic Sea and in approximately 30-50 km width stripe along the sea shore. Industrial generation of power in the wind farms is the most purposeful in this region. Wind turbines (WT) of small and medium scale can be installed in the best sites in other regions of the country. They can operate in stand-alone or grid-connected mode. Anyway, the better option would be the grid-tied operation just because the usage of expensive batteries for power storage is not necessary in this case.

The simplest scheme of wind energy conversion into the electric power is in case when the squirrel cage motor is used for operation in the generator's mode. This way of wind energy conversion was used rather often at the beginning of the wind power development. However, this power conversion system can operate efficiently only at high wind speeds. The stand-alone mode of operation is possible in this case but the grid-connected option is more reliable and more efficient.

Synchronous generators are used in wind energy conversion systems in both modes of operation: stand-alone and grid connected. The synchronous generator can be connected into the power grid directly or over the grid-tied inverter [2].

Reasoning of the wind energy conversion system with double-fed generator

Currently double fed asynchronous machines (DFM) often are used in the WT of large capacity (700÷3000 kW). Circuits of rotor of the DFM are connected with power grid over the converters. Usually such system of wind energy conversion operates well enough, however only at high wind speeds (8-15 m/s) [2]. Additionally, the converter used for the connection of rotor circuit with power grid is rather expensive. Therefore it would be purposeful to research a simplified scheme for wind energy conversion in WT capacity 50-250 kW where the DFM operates like the asynchronous motor working in dynamic braking mode. Stator circuit of the DFM is fed by the DC from the AC/DC converter in order to excite the generator. Rotor circuit of the DFM is connected with power grid over the inverter as it is shown in Fig. 1.

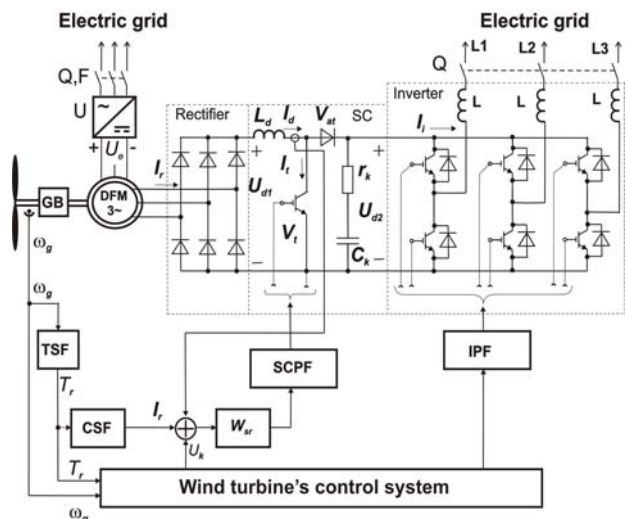

Fig. 1. Simplified electrical scheme of WT with DFM

Another peculiarity of this wind energy conversion scheme is the power storage circuit SC inserted in the power conversion chain between the rectifier and the inverter.

As it is shown in Fig. 1, the stator circuit of DFM is excited by the non-controlled rectifier U, which is connected to the electric grid through the switch Q, F. The rotor circuit of DFM is connected to the electric grid through the rectifier, the shorting and energy storage circuit SC, the inverter and the switch Q. The circuit has the shorting transistor V_t and the power storing elements L_d and C_k .

Wind turbine's control system changes the angle of inversion (by means of inverter's pulse former IPF) and the width of shorting pulse (by means of shorting circuit pulse former SCPF) depending on the shaft's rotational speed ω_g , and, therefore, simultaneously changes the quantity of energy stored in the reactor L_d . The active and reactive energy, supplied into electric grid from the WT, changes dependently on this angle and pulse width.

Power supply into electric grid from the wind power conversion system (Fig. 1) can be controlled within period of 10 milliseconds. When the shorting circuit is used, amount of the reactive power supplied or taken from the grid can be controlled. It depends on the inverting and shorting angles with respect to the grid voltage phase.

Mathematical description and model of the WT's power circuits

Further going researches will be based on the mathematical description and model of the proposed WT's power conversion system. First of all it will be performed for the power circuits. The equivalent scheme of the DFM shown in Fig. 2 will be used for this purpose [3].

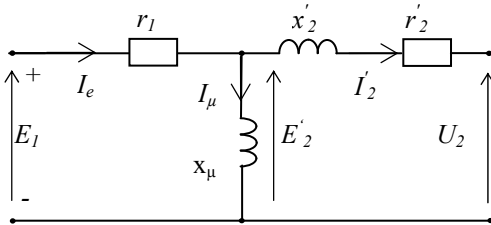

Fig. 2. Equivalent scheme of the generator

Usually the stator's windings are fed by the DC current $I_{\bar{z}}$, which is close to the rated AC current I_N in order to create the proper exciting flux. The exciting current $I_{\bar{z}}$ can be defined more exactly by using the following formulas [3]:

$$I_{\bar{z}}^2 = I_2'^2 + 2I_{\mu}' \cdot I_2' \cdot \sin \varphi_2 + I_{\mu}'^2, \quad (1)$$

$$\sin \varphi_2 = \frac{x_2'^2}{\sqrt{\frac{r_2'^2}{s^2} + x_2'^2}}, \quad (2)$$

where $I_{\bar{z}}$ - the exciting current; I_{μ}' - the magnetizing current; I_2' - the reduced current of the rotor; r_2' , x_2' - the reduced active and inductive resistances of the rotor.

The ratio of generator's angular speed and its no load angular speed s is calculated as follows:

$$s = \frac{\omega_g}{\omega_{g0}}, \quad (3)$$

where ω_g is the angular speed of the generator; ω_{g0} - the angular synchronous speed of the generator.

The following simplified formula is mostly used for calculation of the exciting current $I_{\bar{z}}$:

$$I_{\bar{z}} = I_N \cdot \sqrt{3} \cdot \cos 30^\circ = 1,22 \cdot I_N. \quad (4)$$

The necessary voltage of the DC power source for feeding of the exciting circuit is calculated according to this formula:

$$U_{\bar{z}} = 2 \cdot r_1 \cdot I_{\bar{z}}, \quad (5)$$

where r_1 - the active resistance of the generator's stator winding.

Voltage of the DFM generated in the rotor's windings E_2' is calculated as follows:

$$E_2' = E_{2N} \cdot s, \quad (6)$$

where E_{2N} - the rated delta voltage of rotor (at $s=1$).

The generator is loaded through the rectifier. The rectified parameters of the DFM can be calculated by formulas presented in previous authors' publication [4]. The rectified internal voltage of the generator can be calculated by using the formula:

$$e_{g0} = \frac{2\sqrt{2} \cdot m}{\pi} E_{2f}' \cdot \sin \frac{2 \cdot \pi}{m} \cdot \sin \frac{\pi}{m}. \quad (7)$$

Phase voltage of the generator's rotor can be expressed as this:

$$E_{2f}' = \frac{k_e \cdot \omega_g}{\sqrt{3}}, \quad (8)$$

where

$$k_e = \frac{E_{2N}}{\omega_{g0}}. \quad (9)$$

Effective phase current of the generator's rotor depends on the rectified current and on the angle of commutation:

$$I_{2f} = I_d \cdot \sqrt{\frac{2}{3} - \frac{\gamma}{3 \cdot \pi}}. \quad (10)$$

The diodes' commutation angle γ can be calculated by using this formula:

$$\gamma = \arccos \left(1 - \frac{\sqrt{2} \cdot x_K \cdot I_d}{U_2} \right). \quad (11)$$

Voltage drop due to the commutation of rectifier's diodes u_K can be described by the following expression:

$$u_K = \frac{m}{2 \cdot \pi} \cdot x_K \cdot I_d. \quad (12)$$

where in formulas (8)-(12) E_{2f} – the effective phase voltage of the rotor's open circuit; m – the number of pulsations of the rectified voltage; U_2 – the effective delta voltage of the rotor; k_c – factor of the rotor's internal voltage; ω_g – the angular speed of the rotor; x_K – the inductive resistance of the diodes commutation; I_d – the rectified current; γ – the commutation angle of the diodes.

It can be admitted for the evaluating calculations that $x_K \approx x_2$ (x_2 – the inductive reactance of rotor's phase).

Mathematical descriptions of the electromagnetic processes taking place in the converter's power circuits have been made by using the simplifications well known in theory of converters' circuits [4, 5, 6]. So the n -phase circuits of converter will be substituted by the one-phase equivalent scheme. Power switches will be considered as ideal.

One-line scheme of the researched WT circuitry is shown in Fig. 3.

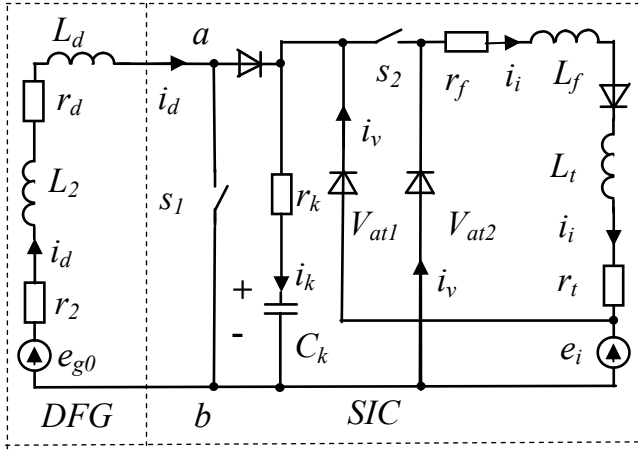

Fig. 3. Equivalent scheme of the wind turbine's power circuits

As it is shown in previous works of authors [4, 5, 7] the DFM generator (Fig. 3) operates in the two basic modes: shorting mode – when the switch S_1 is closed, and power inverting mode – when the switch S_1 is opened and switch S_2 is closed. When the generator is operating in the shorting mode (S_1 – ON) its power circuits can be described as follows:

$$\begin{cases} \frac{di_d}{dt} = \frac{1}{L_d} (u_d - r_d \cdot i_d); \\ u_d = e_{g0} - u_g - u_K; \\ u_g = 2 \cdot r_2 \cdot i_d + 2 \cdot L_2 \cdot \frac{di_d}{dt}; \\ u_K = \frac{m \cdot x_K}{2 \cdot \pi} \cdot i_d; \end{cases} \quad (13)$$

where u_g – the voltage of the generator; i_d – the rectified current of the generator; r_2 – the active resistance of the generator; r_d – the active resistance of the reactor; L_2 – the inductance of the generator; L_d – the inductance of the reactor.

When the switch S_1 is switching off and the switch S_2 does not switched on yet the generator power circuits can be described as follows:

$$\begin{cases} \frac{di_d}{dt} = \frac{1}{L_d} (u_d - r_d \cdot i_d); \\ \frac{du_c}{dt} = \frac{1}{C_k} \cdot i_k; \\ u_d = e_{g0} - u_g - u_{ab} - u_K; \\ u_g = 2 \cdot r_2 \cdot i_d + 2 \cdot L_2 \cdot \frac{di_d}{dt}; \\ u_{ab} = U_{c0} + r_k \cdot i_k = k_s \cdot E_{im} + r_k \cdot i_k; \\ u_K = \frac{m \cdot x_K}{2 \cdot \pi} \cdot i_d; \\ i_d = i_k; \end{cases} \quad (14)$$

where E_{im} – the maximum value of the grid's delta voltage; u_c – the voltage of the storing capacitor C_k ; i_k – the current of the storing capacitor C_k ; k_s – coefficient of the rectifier's scheme.

When the generator is operating in the inverting mode (S_1 – OFF, S_2 – ON) its power circuits can be described by means of the system of differential and algebraic equations as follows:

$$\begin{cases} \frac{di_d}{dt} = \frac{1}{L_d} (u_d - u_{ab} - r_d \cdot i_d); \\ \frac{di_i}{dt} = \frac{1}{L_i} (u_{ab} - e_i - r_i \cdot i_i); \\ \frac{du_c}{dt} = \frac{1}{C_k} \cdot i_k; \\ u_d = e_{g0} - u_g - u_K; \\ u_g = 2 \cdot r_2 \cdot i_d + 2 \cdot L_2 \cdot \frac{di_d}{dt}; \\ u_K = \frac{m \cdot x_K}{2 \cdot \pi} \cdot i_d; \\ U_{c0} = k_s \cdot E_{im}; \\ u_{ab} = U_{c0} + r_k \cdot i_k; \\ i_k = i_d - i_i; \end{cases} \quad (15)$$

where e_i – the counteracting electromotive force of the grid; $r_i = r_t + r_f$ – the active resistance of the inverter circuit; r_t – the active resistance of the grid; r_f – the active resistance of the filter; $L_i = L_t + L_f$ – the inductance of the inverter's circuit; L_t – the inductance of the electric grid; L_f – the inductance of the filter; i_i – the inverted current.

When the switch S_1 is in the position OFF and the switch S_2 is just after the switching off, the generator power circuits can be described by using system of equations 15 with some modifications: $e_i=0$ and current $i_v = -i_i$ (see Fig 3).

When the switch S_1 is in the position ON and the switch S_2 is just after the switching off, the generator power circuits can be described as follows:

$$\begin{cases} \frac{di_i}{dt} = \frac{1}{L_i} (u_{ab} - r_i \cdot i_i); \\ \frac{du_c}{dt} = \frac{1}{C_k} \cdot i_k; \\ u_{ab} = U_{c0} + r_k \cdot i_k; \\ i_k = i_v = i_i. \end{cases} \quad (16)$$

Mechanical part of the DFM can be described like it was done in the papers [4, 7]:

$$\begin{cases} \frac{d\omega_g}{dt} = \frac{1}{J} \cdot (T_{ig} - T_g - T_f); \\ T_{ig} = \frac{P_t}{\omega_t \cdot i}; \\ T_g = k_m \cdot I_f; \\ T_f = k_f \cdot \omega_g; \end{cases} \quad (17)$$

where T_g – the torque of generator; T_{ig} – the torque of wind turbine shaft calculated to the generator's rotor; T_f – the combined torque of viscous friction of rotor and load; J – the combined inertia of rotor and load; i – reduction (multiplication) factor of the gear; ω_t – the angular velocity of the wind turbine shaft; ω_g – the angular velocity of the generator's rotor; k_m – torque factor; k_f – friction factor; P_t – the power produced by the wind turbine.

Characteristics of wind turbines

Wind turbines can be described by means of non-dimensional dependences of the power coefficient c_p on the tip-speed ratio λ . Coefficient λ can be calculated by using this formula:

$$\lambda = \frac{R \cdot \omega_t}{v_w}, \quad (18)$$

where R is the radius of wind rotor; ω_t – the angular velocity of wind turbine rotor; v_w – the wind speed.

The power coefficient c_p for the wind turbine under research can be approximated as follows:

$$\begin{aligned} c_p = & -2.463e - 5 \cdot \lambda^7 + 6.6718e - 4 \cdot \lambda^6 \\ & - 0.006942 \cdot \lambda^5 + 0.0339 \cdot \lambda^4 - 0.0778 \cdot \lambda^3 \\ & + 0.08049 \cdot \lambda^2 - 0.0296 \cdot \lambda + 0.0063. \end{aligned} \quad (19)$$

The mechanical output power P_t at the shaft of the wind turbine can be calculated as follows [8]:

$$P_t = \frac{1}{2} \cdot \rho \cdot c_p(\lambda) \cdot A \cdot v_w^3, \quad (20)$$

where $\rho = 1,225 \text{ kg/m}^3$ is the air density; $A = \pi R^2$ – the swept area of the wind rotor.

The torque T_t at the shaft of the wind turbine can be calculated as follows:

$$T_t = \frac{P_t}{\omega_t}, \quad (21)$$

Dependences of the wind turbine torque T_t on the angular velocity ω_t when the wind speed v_w is constant are given in Fig. 4. The thicker line in the same figure shows the optimal load torque defined for the generator of the researched wind turbine. If load of the wind rotor will be controlled according to this curve, the wind turbine will supply into electric grid the maximal power, which value will depend only on the wind speed.

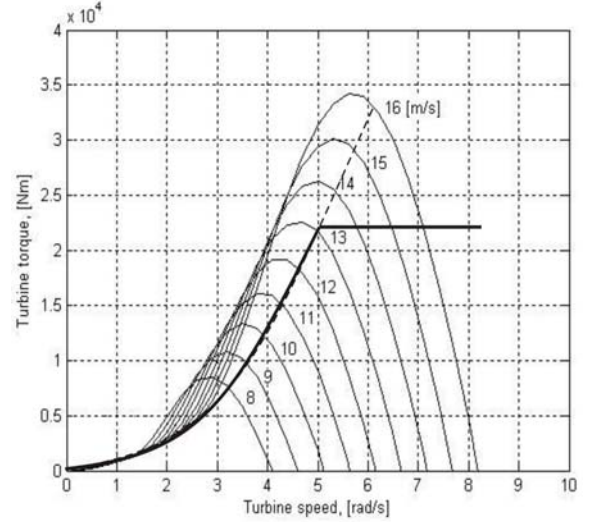

Fig. 4. Dependences of the wind turbine torque T_t on the angular velocity ω_t when the wind speed is constant

The torque-speed characteristics are implemented in the torque signal forming (TSF) unit, which is shown in Fig.1. The value of the signal for reference the load torque of the wind turbine's generator is calculated in the TSF unit accordingly to the measured angular velocity of the wind rotor. After this the current signal forming (CSF) unit calculates the value of the generator's rectified current reference signal because load of generator is controlled by means of changing its rectified current. The rectified current is controlled by the pulse-width modulation by means of the shorting unit SC shown in Fig. 1.

Apart from the function of maximization of power produced by the wind turbine, the described control system has one more advantage: the system has a certain effect of filtration because it do not transmit into the control circuits any rapidly changing variations of the wind rotor's power caused by the fluctuations of wind speed and aerodynamic harmonics of torque.

Mathematical model and simulation

Mathematical model of the researched wind turbine is shown in Fig. 5 and consists of the three main parts: double fed machine (DFM), wind turbine and storage and inverting circuits (SC and I).

Mathematical model for the DFM is made up using the systems of equations (13, 14, 15 and 17) as well as equations (1-12). Mathematical model of the storage and inverting circuits is elaborated by application of the previously published works of authors [4, 5, 7].

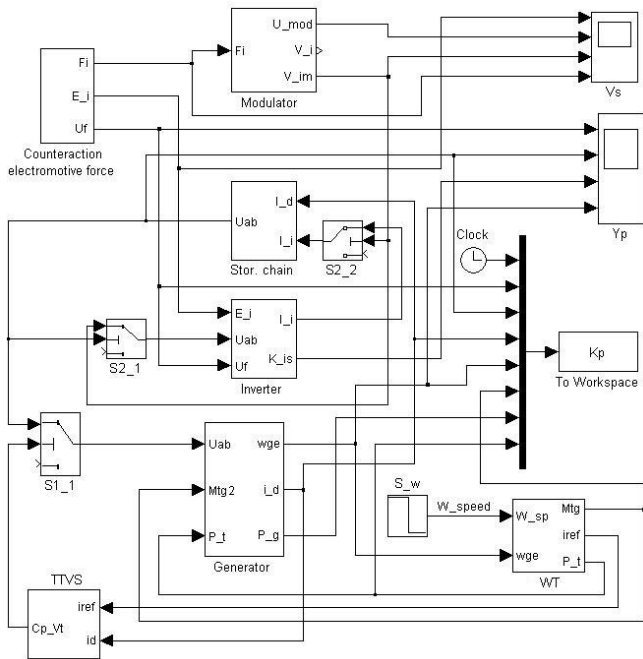

Fig. 5. Mathematical model for the WT's power system

Mathematical model of the wind turbine is based on the equations (18÷21). The reference rectified current I_r (Fig. 1) is calculated in the model's block WT according to the formula presented in the previous paper of authors [4].

Results of the WT's operation research

Wind turbine is purely non-linear object, which is described by the non-linear equations (18 ÷ 21 equations and system of equations 17). One of the best methods for research of this type of systems is the mathematical modelling and simulation. Therefore the researches of the proposed wind energy conversion system based on the double-fed machine were carried out by using of MATLAB/SIMULINK programme package. Duration of simulation depends on the time constants of the researched system's blocks. When the inertia of wind rotor is large and the time constants of converter are small, the duration of simulation is long. Therefore in our case the initial terms were used in order to decrease the time of simulation: it was considered that wind turbine is rotating with angular velocity close to the steady value, which depends on the value of wind speed.

The quality of response of the wind turbine into the control signal and wind speed changes was performed by the simulation. Results of simulation are presented below in form of experimental curves.

The case when all power generated by the wind turbine is supplied into electric grid is researched. Results of researches of the WT operating are presented in Fig. 6. There is shown the process of operating WT when the load increases from zero to particular value and the wind velocity suddenly drops from 9 m/s down to 5 m/s.

Initially wind turbine is switched on for operation in the idle mode. The load of wind turbine starts to increase only after 4 s. At first the load increases very slowly because the converter is operating in the mode of intermittent current

without the power supply into electric grid. The converter starts to operate in the mode of continuous current approximately after 6,5 s. The power supply into electric grid begins and load power of the generator rapidly reaches the set value. As it can be seen in Fig. 6, the WT's load control process is sufficiently qualitative.

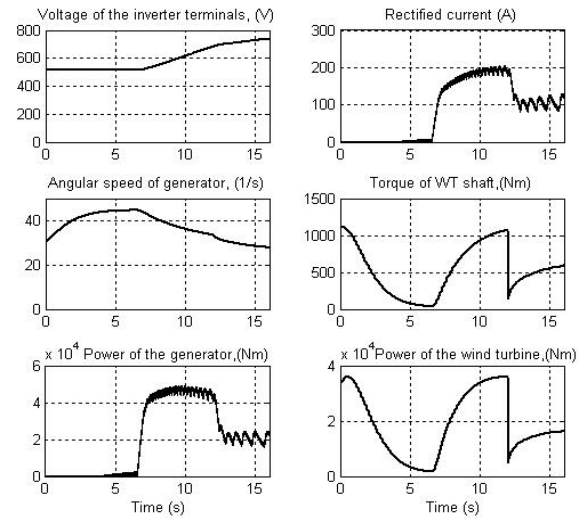

Fig. 6. Curves of the WT's power system parameters at the jump of generator's load reference signal U_v from 1 to 8 V after 4 s and drop of the wind speed v_w from 9 to 7 m/s, at $t = 12$ s)

As we also can see in Fig. 6, after the wind speed drop the WT moves to another point of operation. After this the angular velocity and torque of the WT, the rectified current and power of the generator decreases.

However, the form of the inverted current is not sinusoidal. Therefore the filters for the inverted current must be installed on output of the inverter.

Conclusions

1. Simplified grid-connected wind energy conversion system based on double-fed machine of moderate capacity is proposed.
2. Stator windings of the double-fed machine are fed by the DC from the AC/DC converter when rotor circuit of the machine is connected with power grid over the inverter.
3. Load of the wind turbine's generator in the proposed energy conversion system is controlled dependently on the wind speed in order to maximize the energy output.
4. Control of the rectified current of double-fed machine and inverted current by the pulse-width modulation allows receiving a sufficient quality of wind turbine's operation.
5. Mathematic model of the proposed wind energy conversion system with double-fed machine allows researching of the wind turbine's dynamic properties.
6. Researches performed on basis of the mathematical model proved the necessity to increase the load of wind turbine slowly enough in order to avoid the considerable potentially harmful mechanical forces.

7. Research of the mathematical model of wind energy conversion system with double-fed machine confirmed the idea that using of the pulse-width modulator and control system for the wind turbine's load control allows optimal controlling of the power supplying into electric grid depending on the wind speed.

References

1. Wind power set to become world's leading energy source. Earth Policy institute. June 25.2003. (www.earth-policy.org/2008.04.26).
2. Papathanassiou S.A., Hatziaargyriou N.D. Technical requirements for the connection of dispersed generation to the grid. (<http://users.ntua.gr/stpaphath/publications>).
3. Москаленко В.В. Автоматизированный электропривод. М., Энергоатомиздат, 1986. 416 с.
4. Adomavičius V., Ramonas Č., Kepalas V. Control of wind turbine's load in order to maximize the energy output //

Electronics and Electrical Engineering. – Kaunas: Technologija, 2008. – No. 8(88). – P. 71–76.

5. Ramonas Č., Kepalas V., Adomavičius V. Iš atsinaujinančių šaltinių gautos energijos konversijos procesų tyrimas // Elektrotechnika ir Elektronika. – Kaunas: Technologija, 2006. – No. 2(66). – P. 78–83.
6. Paulauskas M., Kepalas V., Ramonas Č. Platuminio asinchroninio ventiliinio kaskado dinamika // ISSN 1392 – 1215 Elektronika ir elektrotechnika, 1996. – No. 4(8). – P. 56–58.
7. Kepalas V., Ramonas Č., Adomavičius V. Connection of the RES-based Power Plants into the Electric Grid // Electronics and Electrical Engineering. – Kaunas: Technologija, 2007. – No. 8(80). – P. 67–72.
8. Aliprantis D. C., Papathanassiou S. A., Papadopoulos M. P., Klads A. G. Modeling and control of a variable speed wind turbine equipped with permanent synchronous generator. (<http://users.ntua.gr/stpaphath/publications>).

Received 2009 06 22

Č. Ramonas, V. Kepalas, V. Adomavičius. Research of the Usage of Double-fed Generators in Wind Turbines // Electronics and Electrical Engineering. – Kaunas: Technologija, 2009. – No. 8(96). – P. 27–32.

Results of researches of the wind turbine with double-fed generator when its stator is fed from the DC power source are described in the paper. Usually stator and rotor of the wind turbine's double-fed generator is connected with electric grid over the electronic converters. If capacity of wind turbine is not considerable, application of the generator's exciting over the stator's windings can be acceptable and justified in order of simplification of wind power conversion system. Only one converter is used in this case for connection of the rotor circuit with electric grid. Equivalent scheme and equations, which can be used for calculation of parameters of the power supplied into electric grid depending on the wind speed, are given in the paper. Electromagnetic processes for the intervals of operation, shorting and inverting are described by means of the system of differential equations. Mathematical model of the wind power conversion system is based on this system. Load of the wind turbine and pulse-width mode of operation of the inverter are taken into consideration. Results of the research showed the possibility to keep the wind turbine's operation on the maximum available power depending on the wind speed. However, the inverted current has a pulse shape. Therefore the filters should be used after the inverter in order to make the inverted current closer to the sine wave. Ill. 6, bibl. 8 (in English, summaries in English, Russian and Lithuanian).

Ч. С. Рамонас, В. П. Кепалас, В. Б. Адомавичюс. Исследование применения генераторов двойного питания в ветряных электростанциях // Электроника и электротехника. – Каунас: Технология, 2009. – No. 8(96). – P. 27–32.

В статье рассматриваются вопросы применения генераторов двойного питания в ветряных электростанциях. Обычно в ветряных электростанциях применяются генераторы, как статор, так и ротор, соединяются с электросетью при помощи полупроводниковых преобразователей. Для генераторов небольшой мощности удобнее в обмотку статора подать постоянный ток возбуждения, а ротор с электросетью соединить через сетевой инвертор. В статье дана принципиальная схема такого соединения, а также эквивалентная схема и система дифференциальных уравнений, по которым можно рассчитать мощность, передаваемую в электросеть в зависимости от скорости ветра и рабочего интервала. Применяя данные уравнения, разработана математическая модель. Результаты моделирования показывают, что, применяя широтно-импульсное регулирование, можно поддерживать максимальную для каждой данной скорости ветра нагрузку ветряной электростанции. При таком регулировании нагрузки инвертируемый ток получается импульсный. Поэтому в схеме инвертора должны применяться фильтры для того, чтобы инвертируемый ток был приближен к синусоидальному току. Ил. 6, библи. 8 (на английском языке; рефераты на английском, русском и литовском яз.).

Č. Ramonas, V. Kepalas, V. Adomavičius. Vėjo elektrinių su dvigubo maitinimo generatoriais tyrimas // Elektronika ir elektrotechnika. – Kaunas: Technologija, 2009. – Nr. 8(96). – P. 27–32.

Straipsnyje nagrinėjami dvigubo maitinimo generatorių naudojimo vėjo elektrinėse klausimai. Dažniausiai vėjo elektrinėse generatoriaus statorius ir rotorius jungiami su elektros tinklu naudojant puslaidininkinius keitiklius. Daug paprasčiau, ypač jeigu generatoriaus galia yra nedidelė, statorių maitinti nuolatine žadinimo srove, o rotorius sujungti su tinklu per tinklo inverterį. Straipsnyje pateikiama tokios vėjo elektrinės ekvivalentinė schema ir lygtys, pagal kurias galima apskaičiuoti į elektros tinklą tiekiamos energijos parametrus, kai yra žinomas vėjo greitis. Generatoriaus galios grandinių elektromagnetiniai procesai aprašyti taikant intervalų metodą. Visų darbo intervalų: trumpinimo, energijos kaupimo ir energijos atidavimo į tinklą elektromagnetiniai procesai aprašyti diferencialinių lygčių sistemomis. Pagal šias lygčių sistemas sudarytas matematinis modelis, kuriame įvertinama vėjo turbino apkrova, kai inverteris, jungiantis generatorių su elektros tinklu, dirba platuminiu-impulsiniu režimu. Tyrimo rezultatai rodo, kad ištirtoje sistemoje visada galima palaikyti maksimalią vėjo elektrinės apkrovos galią, kurios vertė kinta priklausomai nuo vėjo greičio. Tačiau gaunama invertuojama srovė yra impulsinė, todėl būtina naudoti filtrus, kad ši srovė būtų artima sinusinei. Il.6, bibl. 8 (anglų kalba; santraukos anglų, rusų ir lietuvių k.).