

## The Battery-Driven Electromagnetic Flow Converter with Reduced Power Consumption

R. Katutis, R. Vaikasas, J. A. Virbalis

Department of Electrical Engineering, Kaunas University of Technology,

Studentų str. 48, LT-51367 Kaunas, Lithuania, tel. +370-37-300267, e-mail: arvydas.virbalis@ktu.lt

### Introduction

The electromagnetic fluid flow meters and converters are used for very large purposes and different operating conditions. Both from the point of measurement uncertainty, reliability of the results obtained and the resistance for different outer influence, they are as good as the best converters of other types, including ultrasonic ones.

Measurement of fluid flow is sometimes performed in places difficult to reach, where their maintenance is inconvenient and expensive. They could be installed somewhere further from premises with electric network. In these cases, autonomous supply of fluid flow meters or converters is important. This is relevant also in cases when malfunctions or intentional breaks of electric power supply are possible.

In electromagnetic fluid flow converters, for the purpose to obtain measurement signal proportional to flow magnetic field is necessary. The source of magnetic field is electric current. Thus losses of energy are unavoidable. They must be minimized by all suitable means. Earlier [1, 2] it was analyzed how power consumptions could be reduced by optimal signal processing and making excitation current pulses rare. In this paper it will be analyzed how power consumption needed for the current pulse generation can be minimized.

### Power aspects of rectangular current pulses formatting

The rectangular current pulses are used for magnetic field excitation in the most part of manufactured electromagnetic flow converters. The circuit of excitation current and the pulse shape are showed in Fig. 1 (CS is the current source, CM is the commutator).

The magnetic field exciting coils have significant inductivity. Therefore the current amplitude is achieved after some transient process, the duration of which depends on time constant ( $\tau=L_e/R_e$ ,  $L_e$  and  $R_e$  are, correspondingly, the total inductivity and the resistance of the exciting coils) and is equal to  $(3 - 5)\tau$ . The electrode signal measurement

is not performed in the time interval of transient process, usually. Therefore the power which is needed for creation of this pulse part is gone to waste.

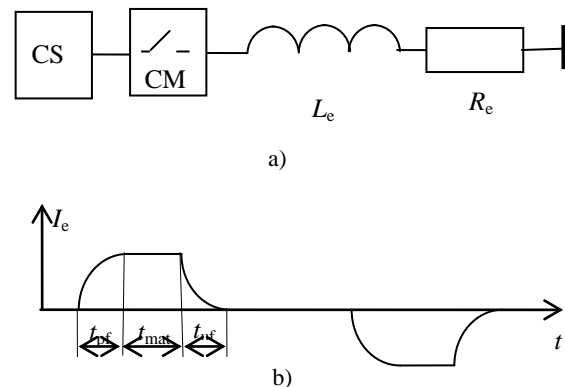

Fig. 1. Typical excitation circuit of electromagnetic flow converter (a) and the pulses formed in this circuit (b)

The measurement of electrode signal is performed when the current value is steady and finished before the current pulse is interrupted. The pulse is interrupted when the excitation current  $I_e$  is maximal. After pulse interruption all this energy is consumed useless in exciting coils circuit when the coils are demagnetize.

The power loss can be decreased by changing of transient process mode in the magnetic field excitation circuit when the pulse of the exciting current is formed. The periodical transient process without the transient damping can be used. This process has two stages. In the first stage the current source energy is transferable to the capacitor energy and stored as the energy of the capacitor electric field. The capacitor is connected to the exciting coils in the second stage. The value of the capacitor capacity must be sufficient that the transient character could be periodic. The periodical power exchange between the capacitor and the exciting coils will be in this case. The electric field energy of capacitor will convert to the magnetic field energy and vice versa. If this process is interrupted, when the current is equal to zero, the parasitic

current pulses will be avoided, therefore the energy consumption will be reduced.

### The excitation current circuit of electromagnetic flow converter with minimal power consumption

The structural scheme of the magnetic field exciting circuit with the minimal power consumption is presented in Fig. 2.

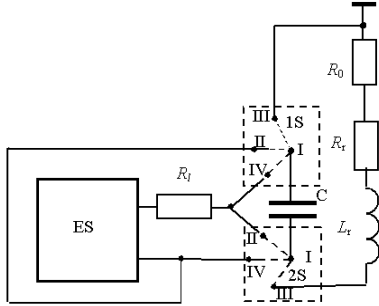

**Fig. 2.** The exciting current circuit of electromagnetic flow converter with minimal power consumption

In the presented circuit ES is the source of the electric power, C is the capacitor, 1S and 2S are the first and second switches with four poles,  $R_0$  and  $R_1$  are the basic and limiting resistors, correspondingly, I – IV are the first – fourth poles of the both switches.

The every period of this circuit action coincides of the four cycles. In the first cycle the poles I and II of first 1S and second 2S switches are connected. The capacitor C is charged of the source ES to the value  $E$ .

The second cycle begins not early than in moment, when the capacitor voltage is equal to the source voltage  $E$ . The I and III poles of the switches 1S and 2S are connected. The discharge of the capacitor begins through serial connection of the exciting coils and the basic resistor  $R_0$ . The transient process performs in RLC circuit. The total resistance  $R_e$  is the sum of the exciting coils resistance  $R_r$  and the basic resistor resistance  $R_a$ . The values of the RLC circuit elements must be chosen this way that the inequality  $R_e = R_r + R_a < R_k$  will be satisfied ( $R_k$  is the critical resistance of the series resonance circuit):

$$R_k = 2\sqrt{\frac{L}{C}}. \quad (1)$$

The transient process will be periodic in this case. The current is changed by the sinusoidal law with the exponential amplitude:

$$i_e = \frac{(-1)^{m-1} E}{\omega_0 L_e} e^{-\delta t} \sin(\omega_0 t + m\pi), \quad (2)$$

where  $m=2n+1, n=0, 1, 2, \dots; \omega_0 = \sqrt{\frac{1}{L_e C} - \frac{R_e^2}{4L_e^2}}; \delta = \frac{R_e}{2L_e}$ .

The second cycle finishes, when the current absolute value becomes equal to zero after the increment to maximum and successive decrement. The poles I and III are connected in the first 1S and the second 2S switches. The duration of the second cycle  $\tau_{II}$  is equal to the current pulse duration  $T$ :

$$\tau_{II} = T = \pi / \omega_0. \quad (3)$$

The third cycle begins. In the initial moment the capacitor voltage has the amplitude value but the contrary sign than in the initial moment of the second cycle. This value is decreased in comparison with the power source voltage to the value:

$$|U_{30}| = E e^{-\delta T} = E e^{-\frac{\pi}{\sqrt{\left(\frac{R_k}{R_e}\right)^2 - 1}}}. \quad (4)$$

If  $R_k \gg R_e$

$$|U_{30}| \approx E e^{-\frac{R_e \pi}{R_k}}. \quad (5)$$

The capacitor charges to the value  $E$  by the law:

$$\begin{aligned} u_{RCIV} &= E - U_{30} \left(1 - e^{-\frac{t}{R_1 C}}\right) \cong \\ &\cong E \left[1 - \left(1 - e^{-\frac{R_e \pi}{R_k}}\right) e^{-\frac{t}{R_1 C}}\right]. \end{aligned} \quad (6)$$

The capacitor voltage absolute value is equal to the source voltage  $E$  in the end of the third cycle but the sign of the capacitor voltage will be contrary than in the end of the first cycle.

The duration of the third cycle is equal to the first cycle  $T_1$  and can be written:

$$\tau_I = \tau_{III} = \tau_p = nT. \quad (7)$$

Therefore the current pulse frequency  $f_p$  is:

$$f_p = \frac{1}{(n+1)T}. \quad (6)$$

In the fourth cycle the I and IV poles of the 1S and 2S switches are connected. The capacitor discharge begins, but the current direction is contrary than in the second cycle and the pulse of the half sine of the contrary sign is formed. The fourth cycle finishes, when after obtained maximal absolute value the current becomes equal to zero. With the fourth cycle finishes the period of the excitation current finishes, too. The dependences of the exciting current and the capacitor voltage on time are presented in the Fig. 3.

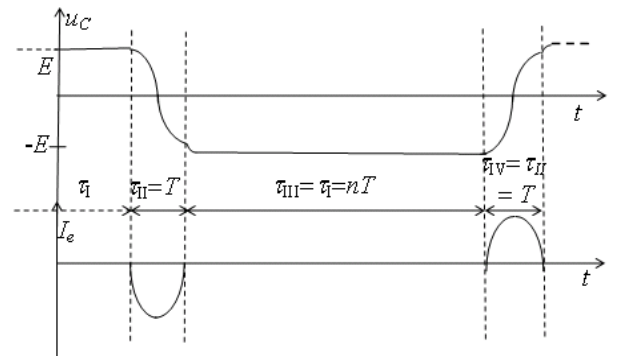

**Fig. 3.** The dependences of current  $i_e$  and voltage  $u_c$  on time

## Electrode signal

The electrode signal  $U_e$  can be expressed as consisting of the three components:

$$U_e = U_s + U_T + U_n. \quad (7)$$

$U_s$  is proportional to the fluid flow component.  $U_T$  is transform component, proportional to the derivative of the magnetic flux acting in the input circuit loop. The input circuit loop consists of the leads joining the electrodes with the measurement unit input.  $U_n$  is the electrode noise signal. The signals  $U_s$  and  $U_T$  shapes are presented on Fig. 4.

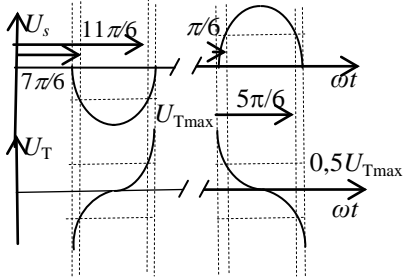

Fig. 4. The shape of the signals  $U_s$  and  $U_T$

The transform signal  $U_T$  is parasitic. For the effective suppression of signal  $U_T$  we suggest to measure the parts of the signal  $U_s$  which is in intervals of the sine phase  $[\pi/6, 5\pi/6]$  and  $[\pi+\pi/6, \pi+5\pi/6]$ . The values of the transform signal  $U_T$  are not more than  $(1/2) U_{Tm}$  ( $U_{Tm}$  – the maximal value of the transform signal) in this interval. The transform signal  $U_T$  is symmetric in respect of the argument value  $\pi/2$ . Therefore, if we will integrate the sum of signals  $U_s + U_T$  in the intervals  $[\pi/6, 5\pi/6]$  and  $[\pi+\pi/6, \pi+5\pi/6]$  we obtain in the integrator output the signal, which is proportional to the flow signal  $U_s$ , only. The integration can be numerical.

In the intervals  $[\pi/6, 5\pi/6]$  and  $[\pi+\pi/6, \pi+5\pi/6]$  there are stored  $\approx 0,86$  of the sinusoidal signal  $U_s$  area and the values of the signal are not less than  $0,5 U_{sm}$  ( $U_{sm}$  – the maximal value of the flow signal). Therefore the measurement accuracy will be practically the same in comparison with case when the measurement is performed in the intervals  $[0, \pi]$  or  $[\pi, 2\pi]$ . But the efficiency of transform signal suppression is a lot better.

The integrating is not sufficient for the noise signal  $U_n$  suppressing. This suppression can be performed using wavelet filters [1,2].

## Reduction of power consumption

The energy of the magnetic field  $W_m$ , which is stored in the excitation coil with the total inductivity  $L_e$  by acting of the current  $I_m$  pulse is equal to:

$$W_m = \frac{L_e I_m^2}{2}. \quad (8)$$

This energy converts to the heat without utility after pulse interruption, when the pulses are rectangular.

If transient process is periodical this energy goes to the capacitor electric field energy when the excitation

currents is equal to zero. In the resonance circuit without losses all magnetic field energy could be converted to the electric field energy:

$$W_m = W_{ei} = \frac{CE^2}{2}. \quad (9)$$

In real circuit the capacitor voltage diminishes to the value  $U_{30}$ , expressed by (4), because energy losses in resistive elements. The energy  $W_c$  stored in capacitor is

$$W_c = \frac{CU_{30}^2}{2}. \quad (10)$$

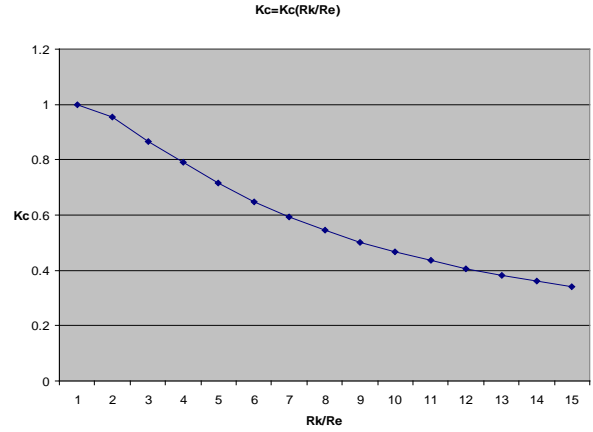

Fig. 5. The dependence of power consumption coefficient on ratio  $R_k/R_e$

The lost energy is restored in the first and third intervals. The relative power consumption  $K_c$  can be expressed evaluating (5), (9) and (10) by this expression:

$$K_c = \frac{W_{ei} - W_c}{W_{ei}} = 1 - e^{-2\pi \frac{R_e}{R_k}}. \quad (11)$$

The dependence of the relative power consumption  $K_c$  on ratio  $R_k/R_e$  is presented in the Fig.5. When  $R_e/R_k \leq 0,1$ , the power economy will be more than 2 times in comparison with the rectangular excitation pulses case.

The supplementary energy consumption can arise in the I and III cycles, if the pauses are very long. The capacitor voltage is kept constant and equal to the  $E$  along these cycles. But the capacitor discharges via the capacitor isolation resistance and the input resistance of the open switches 1S and 2S. We name the equivalent capacitor discharge resistance as  $R_{is}$ . The energy consumption by the discharge  $W_{is}$  evaluating (8) can be expressed:

$$W_{is} = \frac{E^2}{R_{is}} nT. \quad (12)$$

We can express the active energy consumed along one sinusoidal current pulse evaluating (2) as following:

$$W_n = I_e^2 R_e T = \frac{1}{2} \frac{E^2}{R_k} \cdot \frac{R_e}{R_k} \cdot T, \quad (13)$$

where  $I_e$  – the effective value of the excitation current. The relative power consumption  $K_{is}$  because the capacitor discharge we obtain comparing the expressions  $W_{is}$  and  $W_n$ :

$$K_{is} = \frac{W_{is}}{W_n} = \frac{(E^2/R_{is})nT}{(E^2/R_k)T} \cdot 2 \frac{R_k}{R_e} = \frac{2n \cdot (R_e/R_k)}{(R_{is}/R_k)}. \quad (14)$$

The power consumption  $K_{is}$  can be neglected usually because the  $n$  is not more  $10^3$  and the inequalities  $R_e/R_k \leq 10$  and  $R_{is}/R_k \geq 10^6$  are correct for the circuit with the periodical transient process of excitation current.

## Conclusions

1. Power used for magnetic field excitation can be minimized by applying a capacitor and the oscillating character of the transient process. The pulses of excitation current are the half-periods of the sinusoid.

2. We obtain the effective suppression of the transform component integrating the electrode signal in the sine phase intervals  $[\pi/6, 5\pi/6]$  and  $[\pi+\pi/6, \pi+5\pi/6]$ .

3. The power consumption which arises because the discharge of the capacitor between neighbouring current pulses is negligible.

## References

1. **Katutis R., Virbalis J. A.** Development of battery – driven electromagnetic flow converter // *Electronics and Electrical Engineering*. – Kaunas: *Technologija*, 2007. – No. 4(76). – P. 79–82.
2. **Katutis R., Virbalis J. A.** Filtration of electromagnetic flow meter signal by wavelet filters // *Proceedings of the XVII International Conference on Electromagnetic Disturbances, EMD 2007*. – September, 2007. – Bialystok: Technical University. – ISSN 1822–3249. – P. 169–172.

Received 2009 06 02

**R. Katutis, R. Vaikasas, J. A. Virbalis. The Battery-Driven Electromagnetic Flow Converter with Reduced Power Consumption // Electronics and Electrical Engineering. – Kaunas: Technologija, 2010. – No. 1(97). – P. 53–56.**

Power used for magnetic field excitation can be minimized by applying a capacitor and the oscillating character of the transient process. Pulses of the excitation current are the half-periods of the sinusoid in this case. We obtain the more effective suppression of the transform component integrating the electrode signal in the sine phase intervals  $[\pi/6, 5\pi/6]$  and  $[\pi+\pi/6, \pi+5\pi/6]$ . The quantitative evaluation of the power consumption reduction is obtained in respect to ratio between critical and active resistances of the excitation circuit. The power consumption which arises because the capacitor discharge between neighbouring current pulse is negligible. Ill. 5, bibl. 2 (in English; abstracts in English, Russian and Lithuanian).

**Р. Катутис, Р. Вайкаса, Ю. А. Вирбалис. Электромагнитный расходомер с автономным питанием и пониженными энергетическими затратами // Электроника и электротехника. – Каунас: Технология, 2010. – № 1(97). – С. 53–56.**

В электромагнитных расходомерах с автономным питанием расходы энергии можно уменьшить в цепь тока возбуждения магнитного поля включая конденсатор. При периодическом характере намагничивания катушек возбуждения уменьшаются расходы энергии, возникающие из-за размагничивания катушек. В этом случае импульсы тока возбуждения - синусоидальные. Трансформаторную помеху лучше всего подавлять интегрируя сигнал электродов находящихся в интервалах фаз синуса  $[\pi/6, 5\pi/6]$  и  $[\pi+\pi/6, \pi+5\pi/6]$ . Получена количественная оценка снижения расходов энергии в зависимости от отношения между критическим и активным сопротивлениями цепи возбуждения. Возникающие из-за разряда конденсатора между двумя соседними импульсами возбуждения потери можно не учитывать. Ил. 5, библи. 2 (на английском языке; рефераты на английском, русском и литовском яз.).

**R. Katutis, R. Vaikasas, J. A. Virbalis. Mažiau energijos imlių autonominio maitinimo elektromagnetinis skysčio srauto keitiklis // Elektronika ir elektrotechnika. – Kaunas: Technologija, 2010. – Nr. 1(97). – P. 53–56.**

Autonominio maitinimo elektromagnetinių skysčio kiekio keitiklių energijos sąnaudas galima mažinti, į magnetinio lauko žadinimo srovės grandinę įjungiant kondensatorių. Užtikrinant periodinį žadinimo ričių įmagnetinimo pobūdį galima sumažinti nuostolius, atsirandančius dėl ričių išmagnetinimo. Šiuo atveju žadinimo srovės impulsai yra sinusiniai. Transformatorinį trukdį geriausia slopinti integruojant elektrodų signalą esantį sinuso fazių intervaluose  $[\pi/6, 5\pi/6]$  ir  $[\pi+\pi/6, \pi+5\pi/6]$ . Kiekybiškai nustatyta, kaip sumažėja energijos nuostoliai priklausomai nuo santykio tarp žadinimo grandinės kritinės ir aktyviosios varžų. Nuostolių, atsirandančių dėl kondensatoriaus iškvos intervalė tarp dviejų žadinimo impulsų, galima nepaisyti. Il. 5, bibl. 2 (anglų kalba; santraukos anglų, rusų ir lietuvių k.).

DOI: 10.5755/j02.eie.9945