

The Selection of Biotronics Measures

P. Balaišis, D. Eidukas, E. Keras, A. Valinevičius

Department of Electronics Engineering, Kaunas University of Technology

Studentų st. 50, LT-51368, Kaunas, Lithuania, phone: +370 37 300520, e-mail: eugkera@stud.ktu.lt

Introduction

Peculiarities of biological objects (BO) often become a major issue when trying to interconnect them with various technical measures and when attempting to research and control them. These objects are usually attributed to the class of complex objects, for which the potential of growing, reproduction, reaction to the environmental impacts and change in order to initiate or improve the adaptation, flexibility and evolution is characteristic. In major part these objects are autonomous, multi-process, insufficiently researched, multiparametric (when parameters are interconnected) and therefore difficult to model.

When BO and an electronic object (EO) are adequately interconnected [1], the biotronic object (BT) is received. By linking biological and electronic systems (BS and ES), systems of biotronics (BTS) are created. These systems differ from biotronics measures in the fact, that they are being integrated in a specific manner [2].

Integration of BS and ES

BS and ES can be integrated in different ways, depending on the needs of the consumer and the specifics of selected problem. BTS efficiency also depends on the selected method of integration [3].

Assume that BTS interconnects only one BS and one ES. Three variants of their interfacing structure can be distinguished (Fig. 1).

In all cases BS and ES are being influenced by the sets of their environment factors (\vec{F}_B and \vec{F}_E). In the first case (Fig. 1, a) BS and ES are not directly dependent on each other (there is no direct link between them). ES controls one (F_{Bi}) or several ($\{F_{Bi}\}$) factors which influence BS ($F_{Bi} \in \vec{F}_B$). When \vec{F}_B varies, BS operation conditions and at the same time its operation efficiency partly uncontrollably varies. This is a typical and presently widely employed variant of interface between electronics measures and BS. In this case momentary (in time t_1) and average (during time period $t_1 \div t_2$) BS operation efficiencies ($E(t_1)$ and $E_v(t_1 \div t_2)$) [3] will be also

uncontrollable and can be lower than required ($E_p(t_1)$ and $E_p(t_1 \div t_2)$).

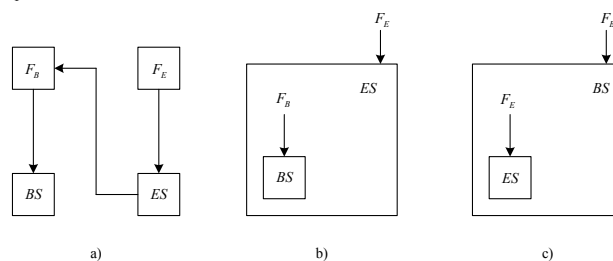

Fig. 1. Three variants of BS and ES composition: a – systems, which directly do not depend on each other; b – ES priority systems; c – BS priority systems

$$E_v(t_1 \div t_2) = \frac{\int_{t_1}^{t_2} E(t) dt}{t_2 - t_1}, \quad (1)$$

here $E(t)$ – dependence of BS operation efficiency on time (t). Main advantage of BTS is the fact that it provides the direct interaction of BS and ES. The system is called integrated [3] system (IBTS), when its subsystems are pursuing the same collective objectives and also have a centralized control.

ES priority integrated systems (Fig. 1, b) are pursuing the objectives of this system and usually make some reservations when implementing objectives of BS, for example, forecasts possible losses due to inadequate operation of BS, etc. In the system with such priority the information about states of BS, when specific objectives of ES are given, can not always ensure the needed reaction in the biological system from the higher level system.

When selecting BS objectives according to BTS priority (Fig. 1, c), it is realistic to expect more efficient implementation of these objectives, spanning many various states, which could be determined by \vec{F}_B factors.

That provides the opportunities to ensure the systemic control of ES, considering conditions and BS states determined by \vec{F}_B factors.

Several or even tens of such IBTS are used in practice. They exchange information and techniques of analysis and (or) techniques of control among themselves. Therefore

they are connected to IBTS network, which can be autonomous or created by employing already operating networks (or their parts). IBTS network specifics consists of peculiarities of measures implemented in its nodes, which assure rational operation of BS and ES.

IBTS network design

General purpose of IBTS network – to assure efficient interchange between separate systems of it (separate levels of it), additional purpose (in some cases) – partially control operation of these systems. As in case of design of any other system of control, in the case of IBTS network design it is also required to form precisely its objectives, tasks, principles of formation and operation. Hierarchy, openness, dynamism, modularity and other criterions are attributed to IBTS network formation principles.

According to the view of functionality, IBTS network of one hierarchical level Fig. 2a, is considerably simpler, open for expansion and guarantees higher autonomy of separate IBTS.

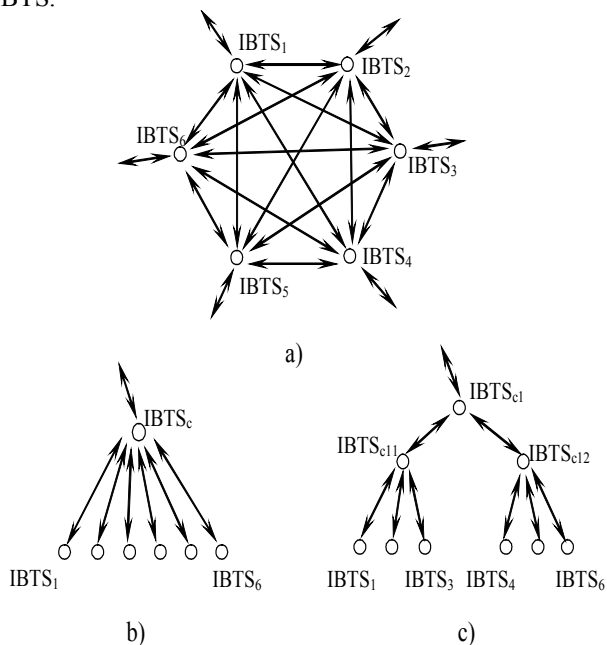

Fig. 2. IBTS networks of one (a), two (b) and three (c) levels

However, if we assess technical efficiency of such network by IBTS₁ task fulfillment (finding required information) probability [4], then in case of communication with IBTS₂ we receive, that it is expressed as

$$E_1 = Kp_1 \cdot P_1 \cdot P_{1-2} \cdot P_{2-1} Kp_2 P_2, \quad (2)$$

here Kp_1 and Kp_2 – steady state availability coefficients of the 1st and 2nd IBTS; P_1, P_2, P_{1-2} and P_{2-1} – probabilities, that 1st and 2nd systems and interfaces between them (in both directions) will accomplish their tasks. If IBTS₂ does not have this information, and this information with equal probability can be located at any one of the rest systems, then average value of efficiency

$$E_{1V} = \prod_{i=1}^{N/2} Kp_i \cdot P_i \cdot P_{i-1} \cdot P_{i-1}, \quad (3)$$

here N – number of IBTS in the network.

If a central system is created in the network (IBTS_c Fig. 2, b),

$$E_1^{(0)} = Kp_1 \cdot P_1 \cdot P_{1-c} \cdot P_{c-1} Kp_c P_c, \quad (4)$$

here Kp_c and P_c – respective indicators of central IBTS.

When $Kp_1 \approx Kp_c, P_1 \approx P_c, P_{1-2} \approx P_{1-c},$ and $P_{2-1} \approx P_{c-1},$ then

$$E_1^{(0)} \gg E_{1V}. \quad (5)$$

Furthermore, the search for information in environment (I_A) is substantially more expensive in one-level IBTS network. Thus it is obvious, that it is more rational to create IBTS network according to the structure presented in Fig. 2, b. IBTS network the structure of which is presented in Fig. 2, c is more efficient than the former only then, when

$$P_{1-c} \cdot P_{c-1} < P_{1-c11} \cdot P_{c11-1} \cdot Kp_{c11} \cdot P_{c11} \cdot P_{c11-c1} \cdot P_{c1-c11}. \quad (6)$$

$P_{1-c}, P_{c-1}, P_{1-c11}, P_{c11-1}, P_{c11-c1}$ and P_{c1-c11} values are determined by interface throughput, busyness, reliability and other features. These values can be increased by using redundant interfaces (when developing IBTS network structure). $Kp_1, Kp_2, \dots, Kp_{c11}$ values depend on IBTS_{1}, IBTS_2, \dots, IBTS_{c11} device and process reliability and ability to react quickly.}

Since main objective of the network is to assure efficient operation of IBTS_{i}, and tasks of these systems: to control BS and protect them and themselves, then the following several control process types can be distinguished: BS operation control; BS protection from disasters; IBTS_{i}} self-protection; other.}

Mostly BS processes are slow. Therefore quick-reaction ability of interfaces and IBTS_{c11} and IBTS_{c1} has a little limiting influence on IBTS_{i} efficiency index value. So the network structures presented in Fig. 2, b and Fig. 2, c would be suitable to control these processes.}}}

When protecting BS from disasters, which mostly are unexpected and abrupt, network structures presented in Fig. 2, a or Fig. 2, b would be more suitable.

Third group control process efficiency is inversely proportional to number of IBTS hierarchical levels, and at the same time to the number of interfaces connecting these levels in serial or parallel manner.

Since IBTS network structure has to be selected during its design, then number of hierarchical levels in it can not be variable. Thus IBTS control information has to be positioned at several several levels of hierarchical network. It can be seen from the results of bionics investigations [1], that in order to increase IBTS network efficiency the reliability control of its components (devices and processes) [2] it is most applicable, investigations of which could be expanded to the creation of separate branch of rebilitronics in the future. But at the present time it falls to rely on IBTS persistence [5] increase (usually by measures of logical reliability increase). Technical measures of IBTS network are presented in Fig. 3.

In Fig. 3 DNS – Domain Name System. DNS server in such network is a program, which serves the address domain name system (DNS). This program is installed in constantly operating IBTS_{c}, which is connected to the Internet. In order to maintain DNS server external visibility from Internet, IBTS_{c} has to have the real IP address.}}

ES (IES) and BTS function in partly autonomous mode, by using information received from LAN servers. MCP and FCP measures are used to control it externally. When there

is not enough information in LAN servers, a DNS server inquiry is made; these servers are controlled by their own FCP, as they are constantly updated and supplied with new information (through MAN, WAN). All IBTS_c maintain connection over these networks. Practically, their databases can be identical. When one IBTS_c fails, the same services can be provided by another system (from {IBTS_{ci}}).

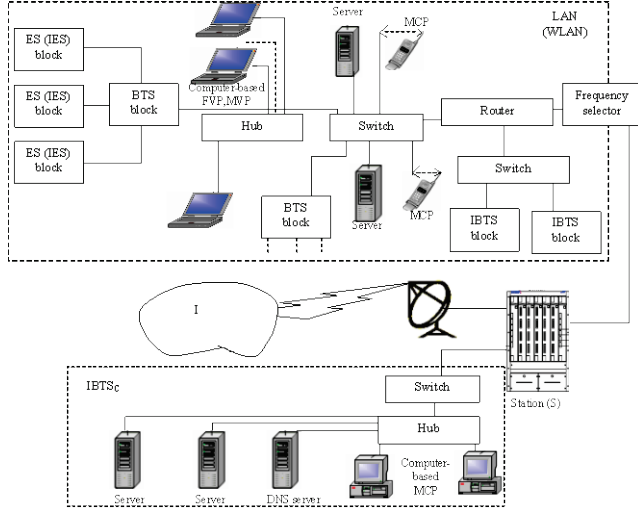

Fig. 3. Connection of IBTS network components (measures) (WLAN – wireless LAN)

Scheme of IBTS network presented in Fig. 3 is not the only possible variant. It can be modified, and new components can be added to it. It is only a structure, demonstrating component interconnections and operation principles.

Efficiency of IBTS network

Structure of IBTS network presented in Fig. 3 is selected for further investigations. Each component in it is characterized by task accomplishment probability [2] (P_{SI} , ..., P_{SM} , P_{BT} , ..., P_D) (Fig. 4) and connections between endpoints of these component series are foreseen. There can be other connection combinations also.

Task accomplishment probability matrix (P) is formed.

$$P = \begin{pmatrix} P_{XX} & P_{XY} & P_{XM} & P_{XS} & P_{XA} & 0 & 0 & 0 & 0 \\ P_{YX} & 0 & P_{YM} & P_{YS} & P_{YA} & P_{YI} & 0 & 0 & 0 \\ P_{MX} & P_{MY} & 0 & P_{MS} & 0 & 0 & 0 & 0 & 0 \\ P_{SX} & P_{SY} & P_{SM} & P_{SS} & P_{SA} & P_{SI} & P_{SD} & P_{SZ} & 0 \\ P_{AX} & P_{AY} & 0 & P_{AS} & 0 & P_{AI} & 0 & 0 & 0 \\ 0 & P_{IY} & 0 & P_{IS} & P_{IA} & P_{II} & P_{ID} & P_{IZ} & 0 \\ 0 & 0 & 0 & P_{DS} & 0 & P_{DI} & 0 & P_{DZ} & P_{DF} \\ 0 & 0 & 0 & P_{ZS} & 0 & P_{ZI} & P_{ZD} & 0 & 0 \\ 0 & 0 & 0 & 0 & 0 & 0 & P_{FD} & 0 & 0 \end{pmatrix}. \quad (7)$$

Since protection measures are not provided in this scheme (protection structure can be developed separately), and IBTS processes (as it was already indicated) are relatively slow, it can be assumed that most of component interconnections (P_{XX} , ..., P_{XA} , ...) will not have a high load and their reliability will be sufficient. Thus it can be assumed that

$$P_{XY} \approx P_{YX}; P_{XA} \approx P_{AX}; \dots; P_{FD} \approx P_{DF}. \quad (8)$$

Then

$$P_{XX} = P_{SI} \cdot P_{BT} \cdot P_{SM} \approx P_S^2 \cdot P_{BT}; \quad (9)$$

$$P_{XA} = P_S \cdot P_{BT} \cdot P_{KM} \cdot P_{KC} \cdot P_{AK}; \quad (10)$$

$$P_{YI} = P_{BT} \cdot P_{KM} \cdot P_M \cdot P_{KM} \cdot P_{IB} = P_{BT} \cdot P_{KM}^2 \cdot P_M; \quad (11)$$

$$P_{SZ} = P_{SR} \cdot P_{KM} \cdot P_M \cdot P_{SK} \cdot P_{ST} \cdot P_W \cdot P_{ST} \cdot P_D = P_{SR} \cdot P_{KM} \cdot P_M \cdot P_{SK} \cdot P_{ST}^2 \cdot P_W \cdot P_D; \quad (12)$$

here P_W – task accomplishment probability of Internet.

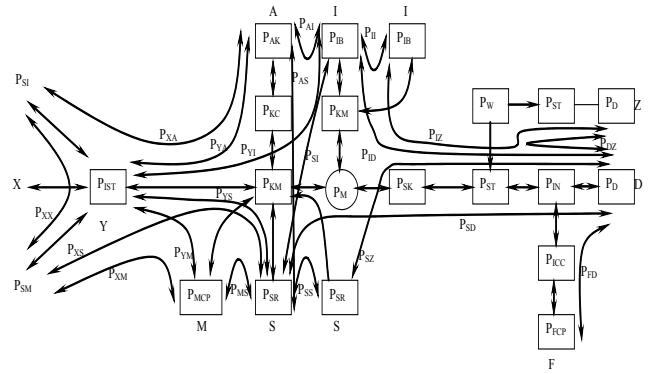

Fig. 4. Scheme of endpoint component interconnections

Significance coefficient matrix (η) of interconnections is formed.

$$\eta = \begin{pmatrix} \eta_{XX} & \eta_{XY} & \eta_{XM} & \eta_{XS} & \eta_{XA} & 0 & 0 & 0 & 0 \\ \eta_{YX} & 0 & \eta_{YM} & \eta_{YS} & \eta_{YA} & \eta_{YT} & 0 & 0 & 0 \\ \eta_{MX} & \eta_{MY} & 0 & \eta_{MS} & 0 & 0 & 0 & 0 & 0 \\ \eta_{SX} & \eta_{SY} & \eta_{SM} & \eta_{SS} & \eta_{SA} & \eta_{SI} & \eta_{SD} & \eta_{SZ} & 0 \\ \eta_{AX} & \eta_{AY} & 0 & \eta_{AS} & 0 & \eta_{AI} & 0 & 0 & 0 \\ 0 & \eta_{IY} & 0 & \eta_{IS} & \eta_{IA} & \eta_{II} & \eta_{ID} & \eta_{IZ} & 0 \\ 0 & 0 & 0 & \eta_{DS} & 0 & \eta_{DI} & 0 & \eta_{DZ} & \eta_{DZ} \\ 0 & 0 & 0 & \eta_{ZS} & 0 & \eta_{ZI} & \eta_{ZD} & 0 & 0 \\ 0 & 0 & 0 & 0 & 0 & 0 & \eta_{FD} & 0 & 0 \end{pmatrix}. \quad (13)$$

Values of significance coefficient values for interconnections are calculated considering what part of all network connections do connections between endpoints comprise, durations of these connections and other factors.

Generalized technical efficiency of overall IBTS network (E) is identified with its average task accomplishment probability at any time t ($P_u(t)$) and is calculated using the following formula:

$$E = P_u(t) = \sum_{i=1}^m \sum_{j=1}^m P_{ij}(t) \cdot \eta_{ij}, \quad (14)$$

here $P_{ij}(t)$ – accomplishment probability of the task, which has been formed between initial i -location and j -endpoint, in time t ; η_{ij} – significance coefficient of connection between initial i -location and j -endpoint; m – number of interconnections realized in IBTS network

(e.g. XY, ... DF, ...). It is possible to consider also connection durations [6], amount of transferred information and other factors when calculating E value.

Integrated information, object and license protection systems can be added to this network.

The research of distance arrangement of phytotrons

More often IBTS is used in phytotrons. Let us say that production can be defined in terms of two rates (Fig.5): quality (Q) and cost ($C_k(Q)$). The demand for the production of different quality can be defined in terms of function $f(Q)$. For example, having chosen three classes and using optimization principles of their values, it is possible to calculate the demand of production of each class (N_1, N_2 and N_3). This will determine the types of phytotrons, their sizes and arrangement variants.

It is seen from Fig. 5 that the sizes of phytotrons which provide the production of the highest quality for a consumer will be the smallest. They will have to be closest to a consumer in order the production would not go wrong while storing and transporting it. The amounts of the production transported will not be large. Therefore, the costs of its transporting will increase. Let us analyze the economic aspects of phytotron arrangement.

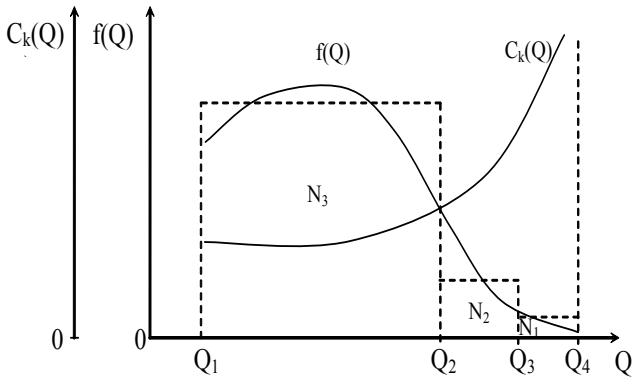

Fig. 5. The choice of the quality classes of production

Going far from a consumer (eg. at the distance l from a city), the rent of one unit of land area $C(l)$ falls nonlinearly. This dependence can be expressed, for example, in the following way:

$$C(l) = c_0 + c_1^{-bl}. \quad (15)$$

here c_0 – fixed component of the cost; c_1 – the basis of power function; b – some rate. Growing crop production in these areas (A_1, A_2 or A_3)(eg. dills, lettuce or cabbage), harvest will be gathered from one unit of area and its value will be $C(A_1), C(A_2)$ or $C(A_3)$ without transportation costs. This value depends on the production quality, however, it will not be the subject of further research. Therefore, not evaluating the transportation costs, it would be purposeful to grow this production not nearer than at the distance of l_1, l_2 or l_3 (respectively) from a city (consumer). The further phytotron will be mounted from the city, the greater differences will be:

$$C_{A1}(l) = C(A_1) - C(l), \quad (16)$$

$$C_{A2}(l) = C(A_2) - C(l), \quad (17)$$

$$C_{A3}(l) = C(A_3) - C(l). \quad (18)$$

$C_{A1}(l), C_{A2}(l)$ and $C_{A3}(l)$ dependences are presented in the second, third and fourth graphs (Fig. 6) where C is an economic rate. The costs ($\{C_{Ti}(A_i, N_i, l)\}$), transporting the amounts N_i of production A_i of one unit of area to a consumer, and ignoring some inessential components, will directly depend on the distance l . In the case of three quality classes they will be the following: $C_{T1}(A_1, N_1, l), C_{T2}(A_2, N_2, l)$ and $C_{T3}(A_3, N_3, l)$.

The differences will constitute producer's profits:

$$C_{p1}(l) = C_{A1}(l) - C_{T1}(A_1, N_1, l), \quad (19)$$

$$C_{p2}(l) = C_{A1}(l) - C_{T2}(A_2, N_2, l), \quad (20)$$

$$C_{p3}(l) = C_{A1}(l) - C_{T3}(A_3, N_3, l). \quad (21)$$

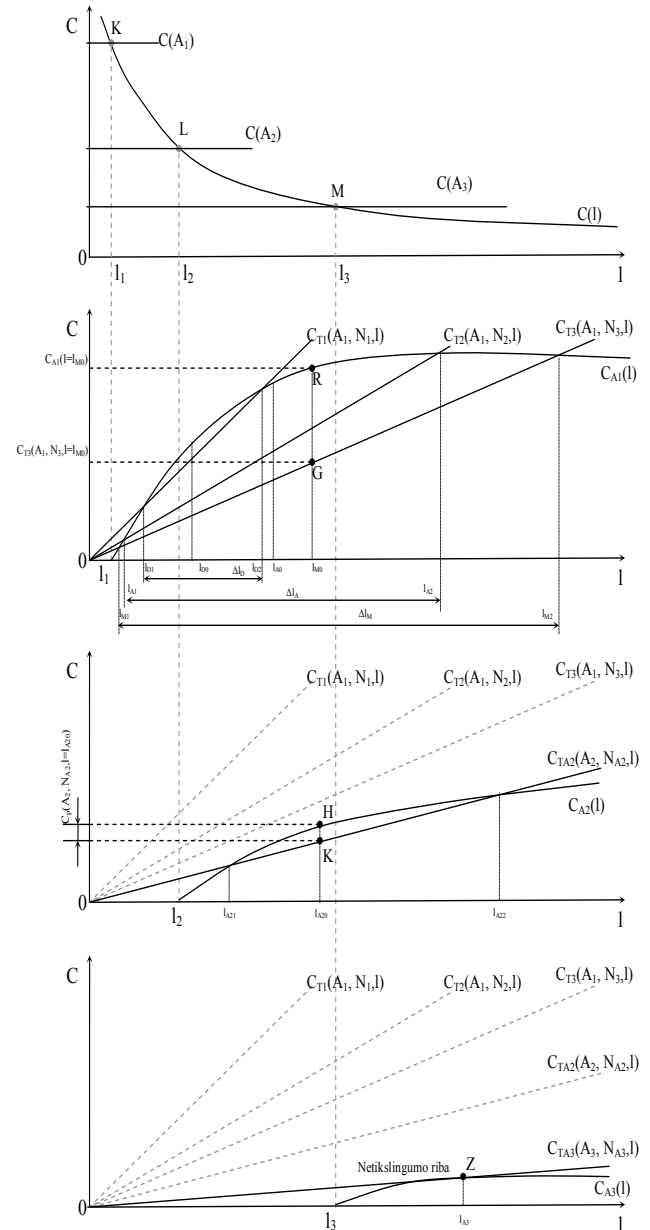

Fig. 6. The choice of the arrangement variants of management means

Therefore, it will be purposeful to mount phytotrons for the manufacture of the production of the highest quality

class, at the distance of l_{D1} to l_{D2} , of medium class at the distance of $l_{A1} \div l_{A2}$ and of the lowest class at the distance of $l_{M1} \div l_{M2}$ (see Fig. 6, the second graph). Having the distance l_{M0} which is a maximum difference,

$$C_{A1}(l) - C_{T3}(A_1, N_3, l) = C_{A1}(l = l_{M0}) - C_{T3}(A_1, N_3, l = l_{M0}) \quad (22)$$

the most rational decision would be to mount the phytotrons ensuring such quality and amounts of manufacture at the distance of l_{M0} from a city. The best place to grow crop production of higher quality is the distance l_{A0} from a city, while the distance l_{D0} is the best for growing the production of the highest quality. Both places are at the intervals of Δl_A and Δl_D but not in their centres. The phytotrons mounted at the distance l_{A20} from a city would be most suitable for the production A_2 (see Fig.6, the third graph). However, the transportation costs $C_{T1}(A_1, N_1, l)$, $C_{T2}(A_2, N_2, l)$ and $C_{T3}(A_3, N_3, l)$ would make such manufacture unreasonable. Even reducing the transportation costs of production A_2 from one unit of area quite much (up to $C_{TA2}(A_2, N_{A2}, l)$), the profit would be much lower (than in the case of A_1), although it would be the maximum profit $C_p(A_2, N_{A2}, l = l_{A20})$ in these conditions. This is determined by the nature of $C(l)$ change.

The function $C_{TA3}(A_3, N_{A3}, l)$ shows the limit of inexpediency of the manufacture of the production A_3 (due to high transportation costs) (see Fig. 2, the fourth graph).

Due to the high cost of land at the interval Δl_D , the means of manufacture which are intended for the manufacture of small amounts of the highest quality production need to be concentrated at the maximum. Here the issues of pollution reduction, waste utilization and other problems arise. Mounting phytotrons at the interval Δl_A , the requirements for their technical parameters are slightly smaller. However, the production produced in the first zone is meant for gourmets, patients, children and so on, in the second zone it is meant for demanding consumers, whereas in the third zone it is meant for mass consumers who buy large amounts of it in the shops, markets and so on.

The choice of the types of phytotrons

At present plants are mostly grown directly in the ground, water medium, air medium which is periodically irrigable and artificial vapour. The technologies of the second, third, fourth types are called hydroponics, aeroponics, diaponics and the phytotrons meant for this are called hydropones, aeropones and diapones. Technical peculiarities of this equipment (the phytotron management systems) are presented in Table 1.

Table 1. Peculiarities of phytotron management systems

No.	The type of phytotron	Peculiarities of phytotron management systems
1.	Diapone	The integrated and concentrated electronic management system; a small number of sensors and performance devices; exceptional flexibility and adaptation of management systems; not more than two management levels; high automation level; the management of temperature, illumination and vapour (together with supply); relatively small overall dimensions; minimal human-

No.	The type of phytotron	Peculiarities of phytotron management systems
		operator's activity.
2.	Aeropone	Dispersed and integrated electronic management system; many sensors and performance devices; four and more management levels; the electronic research system of the conditions of the plants; big enough flexibility of management technologies; the management of sensors, performance devices, their groups, the parameters of the environment and integrated management of phytotrons; relatively large territories served; constant interaction between ES and a human.
3.	Megapone	Combinations of hydropones, aeropones and diapones; the networks of electronic management system of many dispersed types; the electronic research system of the conditions of the plants; universal protection systems against various contingency; the management systems of development; constant analysis and management of complex efficiency.

Conclusions

The peculiarities of electronic management systems of phytotrons depend on the requirements for the quality of the products raised there and also on the distance between it and customer.

Using economic criteria of the arrangement of various types of phytotrons in territories, rational distances among diapones, aeropones and/or diapones and consumers and quantities of the products produced can be calculated and at the same time the structures of electronic management systems can be chosen.

Random nature of the most factors, operating on phytotrons, determines the necessity of using statistical methods and probabilistic evaluation of the efficiency of management systems.

References

- Balaišis P., Gužauskas R., Eidukas D., Valinevičius A. Directions of Efficiency Research for Biotronics Technologies // Electronics and Electrical Engineering. – Kaunas: Technologija, 2009. – Nr. 1 (89). – P. 49–54.
- Valinevičius A., Balaišis P., Eidukas D., Bagdanavičius N., Keras E. Biotronic System Network Efficiency Investigation // Electronics and Electrical Engineering. – Kaunas: Technologija, 2006. – Nr. 3 (67). – P.13–18.
- Eidukas D., Balaišis P., Valinevičius A., Žilyls M. Reliability and Efficiency of Electronic Systems. – Kaunas: Technologija, 2006. – 314 p.
- Valinevičius A., Žickis A., Gužauskas R., Keras E. Investigation of the structure of Data Network of Biotronics

- Systems // Proceedings of the 11th Biennial Baltic Electronics Conference. – Tallinn. – 2008. – P. 269–272.
5. **Balaišis P., Eidukas D., Navikas D., Vilutis G.** Persistence of Electronic devices // Modern Problems of Radio Engineering. Telecommunications and COmputer Science.- Lviv – Slavsko. Ukraine. 2002. – P.13–15
 6. **Balaišis P., Eidukas D., Kavoliūnas R., Plėštys R., Vilutis G.** Research of network efficiency of Information Transmission // ITI 2004: proceedings of the 26th International conference on Information Technology Interfaces, June 7-10, 2004, Cavtat, Croatia/Institute of Electrical and Electronics Engineers. Vol.1. Zagreb: University of Zagreb, 2004. – P. 587–592.

Received 2009 07 09

P. Balaišis, D. Eidukas, E. Keras, A. Valinevičius. The Selection of Biotronics Measures // Electronics and Electrical Engineering. – Kaunas: Technologija, 2010. – No. 1(97). – P. 9–14.

The conception of integration of biologic and electronic systems (BS and ES) in phytotrons when creating the integrated biotronics systems (IBTS) was offered. The priority of BS objectives is assured in IBTS. General principles of formation of IBTS networks were provided. IBTS network efficiency evaluation method was offered. Investigation of deployment techniques of phytotrons (hotbeds, greenhouses and their complexes) which are used in IBTS was performed. Main requirements for the composition of electronic control systems used in phytotrons of various groups were formulated. Ill. 6, bibl. 6, tabl. 1 (in English; abstracts in English, Russian and Lithuanian).

П. Балайшис, Д. Эйдукас, Е. Керас, А. Валинявичюс. Подбор средств биотроники // Электроника и электротехника. – Каунас: Технология, 2010. – № 1(97). – С. 9–14.

Приведена концепция интеграции биологических и электронных систем (БС и ЭС) при создании интегрированных систем биотроники (ИБТС). Обеспечен приоритет целей БС. Приведены основные принципы создания сетей ИБТС. Предложен метод оценки эффективности сетей ИБТС. Сделан анализ размещения фитотронов, используемых в ИБТС. Сформулированы основные требования для создания электронных систем управления, используемых в фитотронах различных типов. Ил. 6, библи. 6, табл. 1 (на английском языке; рефераты на английском, русском и литовском яз.).

P. Balaišis, D. Eidukas, E. Keras, A. Valinevičius. Biotronikos priemonių parinkimas // Elektronika ir elektrotechnika. – Kaunas: Technologija, 2010. – Nr. 1(97). – P. 9–14.

Pasiūlyta koncepcija, kaip integruoti biologinę ir elektroninę sistemas (BS ir ES) kuriant integruotas biotronikos sistemas (IBTS). IBTS užtikrinamas BS tikslų prioritetas. Pateikti pagrindiniai IBTS tinklų kūrimo principai. Pasiūlytas IBTS tinklų efektyvumo vertinimo metodas. Atliktas IBTS naudojamų fitotronų išdėstymo tyrimas. Suformuluoti pagrindiniai reikalavimai, kaip kurti elektronines valdymo sistemas, kurios naudojamos įvairių tipų fitotruonuose. Il. 6, bibl. 6, lent. 1 (anglų kalba; santraukos anglų, rusų ir lietuvių k.).

DOI: 10.5755/j02.eie.9936