

## Compensation of Acting Load Influence on Static Characteristics of Electric Drive by using Inertia Moment Observer

V. Geleževičius

Dept. of Control Technology, Kaunas University of Technology,

Studentų str. 48, LT-51367 Kaunas, Lithuania; phone: +370 37 451610, e-mail: vilius.gelezevicius@ktu.lt

### Introduction

When adjusting speed regulator of an electric drive having hierarchical structure with internal current (torque) regulation loop, influence of the two changing parameters – inertia moment value and magnitude of acting load – are to be evaluated. The inertia moment value of a moving part of the drive predefines its dynamical features and acting load influences on the static accuracy of the drive. In the case of inertia moment change the gain of the speed regulator should be coordinately readjusted in a manner of constancy of gain of the whole speed regulation contour assurance. Influence of acting load on accuracy of speed maintaining process in the steady state of the drive could be diminished or eliminated by means of proper gain value or structure of speed regulator selection.

In the cases (handlers, manipulators, robots and so on) when mass of transported object and its radius of rotation change, the values of moment inertia and acting load of the drive permanently vary. In dynamic state of the drive this requires the gain of speed regulator to be permanently corrected in correspondence with inertia moment change. Necessary gain correction may be realised by using adaptive speed controller with inertia moment observer, designed on the base of MIT or Lyapunov rule [1], or controller with switching control law [2].

The inertia moment observer of the drive works properly in condition the acting load being near to zero, - in the second hand, the load observation, by using Luenberger filter, for example, requires the moment inertia to be constant [3,4]. This paper deals with the problem of inertia moment observer application for two purposes: for inertia moment influence elimination on dynamic characteristics of drive and of acting load influence minimization on static characteristics in the steady state of the drive as well.

### Discussion of structure of adaptive electric drive with inertia moment and acting load observer

Let us suppose the main loop of hierarchical

structure DC drive (Fig.1) consisting of inner current (torque) control contour, depicted by transfer function  $H_{CC}(p)$ , and proportional speed controller  $K_{CS}$ , designed under the quantitative optimum condition. Optimum value of speed controller gain  $K_{CS}$  is defined by parameters of current contour and mechanical part of the drive

$$K_{CS} = \frac{k_C}{4k_S T_{PC} C_M} \cdot J_M = k^*_{CS} \cdot J_M, \quad (1)$$

where  $k_C$ ,  $k_S$  – transfer coefficients of current and speed feedbacks correspondingly;  $T_{PC}$  – small time constant of power converter,  $C_M$  – torque constant of the motor,  $J_M$  – inertia moment of moving part.

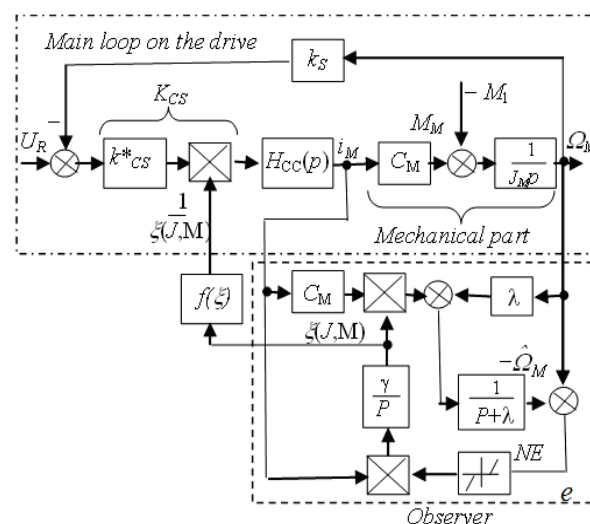

Fig. 1. Structure of adaptive DC drive with inertia moment observer

With inertia moment  $J_M$  of moving part change, the gain  $K_{CS}$  is to be continuously corrected. For inertia moment current value estimation the observer designed according Lyapunov rule may be applied. In the idle case of the drive the estimated value  $\xi(J, M)$  corresponds

to the parameter  $1/J_M$  and may be used for speed controller gain adaptation.

When drive is loaded with static torque  $M_l$ , functioning of an observer is disturbed, and estimated value  $\xi(J, M)$  becomes a complex function of inertia moment  $J_M$  and acting load  $M_l$ . According Fig. 1 process in observed part of the system is defined by equation:

$$\frac{d\Omega_M}{dt} = \left( i_M \frac{C_M}{J_M} - \frac{M_l}{J_M} \right), \quad (2)$$

where  $i_M$  – running current value of the motor;  $M_l$  - acting load value.

Dynamics of observer is modelled by equations:

$$\frac{d\hat{\Omega}_M}{dt} = i_M C_M \xi(J, M) + \lambda (\Omega_M - \hat{\Omega}_M), \quad (3)$$

$$\frac{d\xi(J, M)}{dt} = i_M \gamma (\Omega_M - \hat{\Omega}_M), \quad (4)$$

where  $\Omega_M$  and  $\hat{\Omega}_M$  - running and estimated values of speed of the drive;  $\xi(J, M)$  – complex parameter of observation, depending on inertia moment and load of the drive;  $\lambda, \gamma$  - observer parameters.

In the dynamic state of the drive, when torque developed by motor largely exceeds loading torque value, influence of the loading torque  $M_l$  on functioning of observer becomes insignificant and estimated value of complex parameter  $\xi(J, M)$  approaches to the value of observed parameter  $1/J_M$ . After inverse functional transformation, obtained signal becomes proportional to the value of inertia moment and may be applied as gain correcting signal of the speed controller of drive. It means that presented system in dynamic state functions as an adaptive system in regard of inertia moment change.

In the steady state of the drive on obtains  $i_M = M_l / C_M$  and

$$e = \Omega_M - \hat{\Omega}_M = \frac{M_l \cdot \xi(J, M)}{\lambda}, \quad (5)$$

$$\frac{d\xi(J, M)}{dt} = \frac{M_l}{C_M} \gamma \cdot e, \quad (6)$$

where  $e$  – expresses deflection of observer output  $\hat{\Omega}_M$  signal, corresponding to the speed of unloaded drive from the running speed value  $\Omega_M$  of the motor, loaded by torque  $M_l$ . It is evident that  $e < 0$ .

Taking into account this circumstance, the following conclusion could be drawn from (6) and (5) equations:

- in the steady state of the drive, deflection  $e$  conditions diminution of complex parameter  $\xi(J, M)$ ;
- with diminution of the complex parameter  $\xi(J, M)$  deflection  $e$  diminishes.

It means that in the steady state of loaded drive complex parameter of observer  $\xi(J, M)$  continuously diminishes. After inverse functional transformation it may be applied for automatic increasing of proportional speed controller gain  $K_{CS}$ . With controller gain rise, the static error of the motor speed provoked by loading charge will be diminished.

To avoid unacceptable raise of the speed controller gain able to become a cause of instability of the speed regulation contour, a nonlinear block  $NE$  is introduced into observer structure. Owing to this, drop of the parameter  $\xi(J, M)$  will be interrupted under the condition  $e \leq \zeta$ , where  $\zeta$  – small, predefined value.

### Modelling of the system

The model of the system has been developed according the structure given in Fig.1, under the following initial data of the main loop:  $k_{CS}^* = 125$ ;  $C_M = 1.2$ ;  $k_s = 0.06$   $H_{CC}(p) = 2.8 / (0.02p + 1)$  and with parameters of observer  $\lambda = 500$ ,  $\gamma = 1000$ ,  $\zeta = 0.002 \div 0.005$ .

Variable parameters of the system such as inertia moment  $J_M$  and loading torque  $M_l$  might be freely changed before modelling or during modelling as well. The total gain value of proportional speed controller  $K_{CS} = k_{CS}^* / \xi(J, M)$  was automatically corrected according to output value  $\xi(J, M)$  of observer. The system response curves without and with inertia moment change compensation are presented in Fig. 2

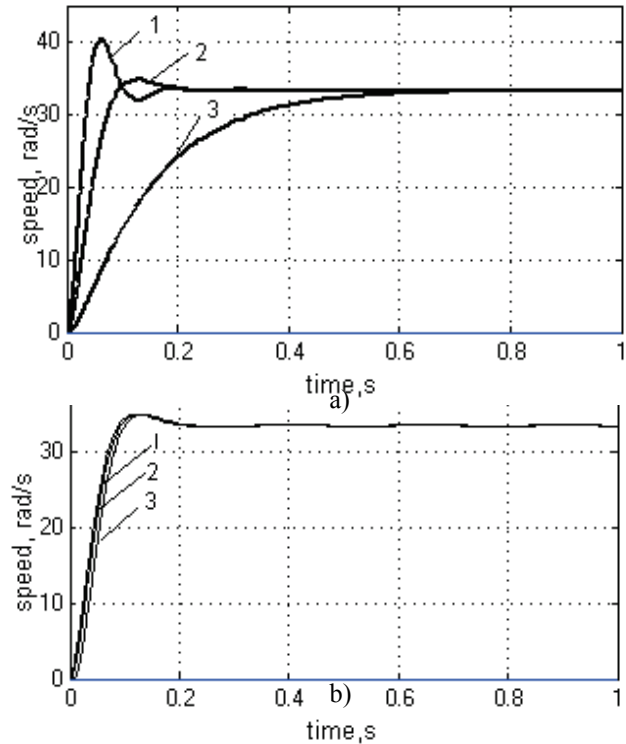

**Fig. 2.** Responses of unloaded system: a) without inertia moment change compensation; b) with inertia moment change compensation using observer signal  $\xi(J, M)$

The responses are obtained for the system with speed controller adjusted under the quantitative optimum condition supposing that inertia moment  $J_M=0,25 \text{ kgm}^2$  (2 curve). As it is shown in Fig. 2a, the responses of the system without compensation significantly differ with inertia moment variations: curve 1 corresponds to case  $J_M=0,1 \text{ kgm}^2$  and curve 3 -  $J_M=1 \text{ kgm}^2$ . The responses of the system with inertia moment change compensation using observer output signal  $\xi(J,M)$  become almost indifferent, inertia moment variations being the same of (Fig. 2b).

The values of output parameter  $\xi(J,M)$  of observer exactly correspond to the observed parameter  $1/J_M$  value and are presented in Fig. 3. The observed parameter values become equal to 10, 4 and 1 correspondingly.

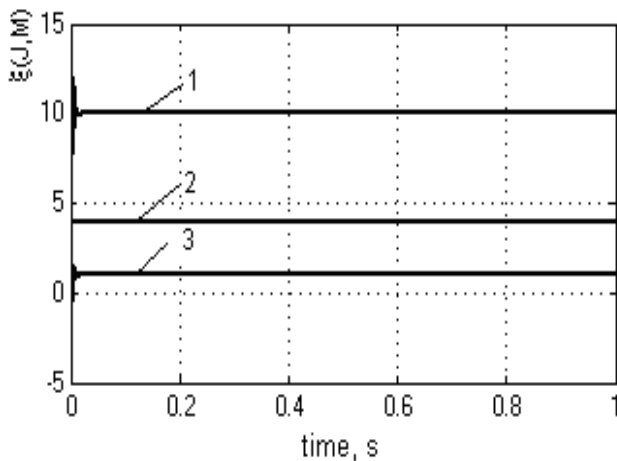
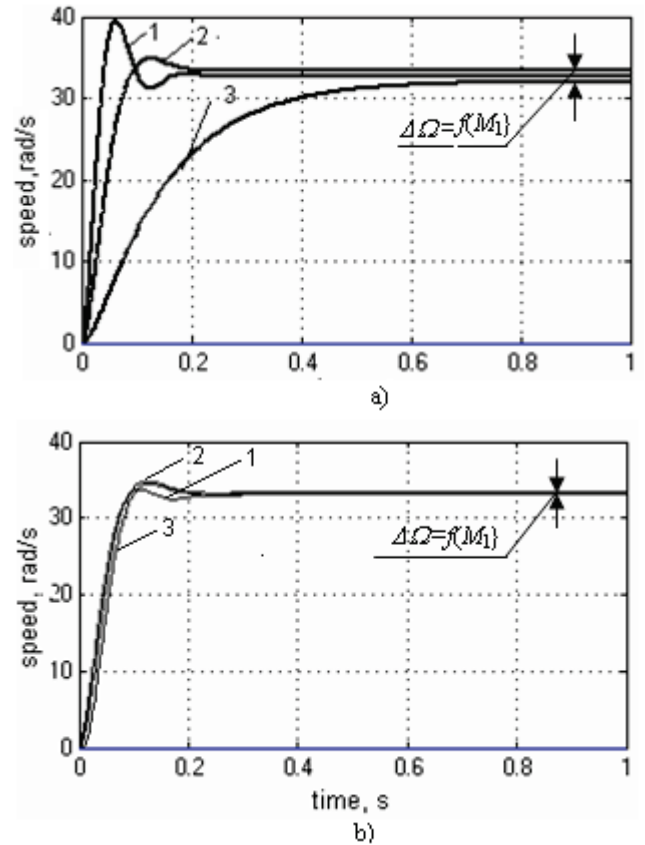

**Fig. 3.** Variation of observer output parameter  $\xi(J,M)$  with inertia moment change in the case of unloaded drive

Further investigations have been carried out the system being loaded with static load  $M_1$  varying from zero up to rated value (for the used DC motor 1G 5 102-0ED rated value of torque is equal to  $M_N = 8.9 \text{ Nm}$ ). The modeling results of loaded drive are presented in Fig. 4.

The responses of loaded system (curves 1 and 3) are compared with response of unloaded and perfectly adjusted system (curve 2) in the Fig. 4a. The curve 1 represents response of detuned system with inertia moment  $J_M=0.1 \text{ kgm}^2$  and acting load  $M_1=4.0 \text{ Nm}$ . The curve 3 corresponds to response of system with inertia moment  $J_M=1 \text{ kgm}^2$  and acting load  $M_1=8.0 \text{ Nm}$ . In all the cases gain of the speed controller remains unchanged and corresponds to optimal value for the case with inertia moment being equal to  $0.25 \text{ kgm}^2$ .

In the Fig. 4b the response curves of the system with implemented speed controller gain corrector by using inertia moment observer signal  $\xi(J,M)$  are presented. There it is clearly seen an efficiency of inertia moment observer application for improvement of dynamic and static characteristics of the drive. Speed error in the steady state of the drive  $\Delta\Omega$  provoked by acting load  $M_1$  significantly decreases. This is caused by the fact that steady state error  $\Delta\Omega$  being coincident with observation error  $e$  stipulates decreasing of output value  $\xi(J,M)$  of observer and, consequently, increasing of speed controller gain correcting parameter  $1/\xi(J,M)$  value. Variation of parameter  $\xi(J,M)$  during control process of the drive is presented in Fig. 5.



**Fig. 4.** Responses of loaded system: a) without inertia moment change and load compensation; b) with inertia moment change and load compensation using observer signal  $\xi(J,M)$

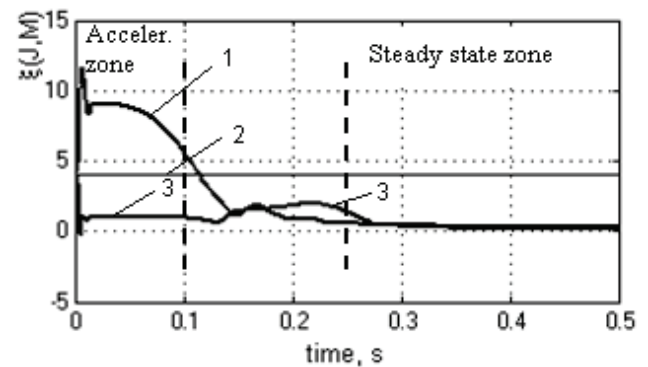

**Fig. 5** Variation of observer output parameter  $\xi(J,M)$  with inertia moment and acting load change

As it is seen from Fig. 5 the process of speed controller gain correction can be divided into three zones: acceleration zone, intermediate zone and steady state zone. In the acceleration zone  $0 \leq t \leq 0.1 \text{ s}$ , torque of the motor is greatly larger than static load  $M_1$ , so observer output signal value is close to the observed parameter  $1/J_M$  value and ensures well correction of speed controller gain, maintaining dynamic quality of the process almost invariant

In the steady state zone observer reacting on emerged error  $e$  begins diminishing of parameter  $\xi(J,M)$  value as long as the condition  $e \leq \zeta$  is reached. The

value of parameter  $\zeta$  is to be chosen as result of coordination of required speed regulation accuracy and desired stability conditions.

In the intermediate zone observer is in transitional regime passing from inertia moment observation state to static error estimation state. Owing to this in this phase the dynamic characteristics of loaded drive are minutely worse than ones of unloaded drive.

Finally, the dynamical and static features of the investigated system are illustrated by responses of loaded system to the bipolar pulse reference signal, presented in Fig. 6.

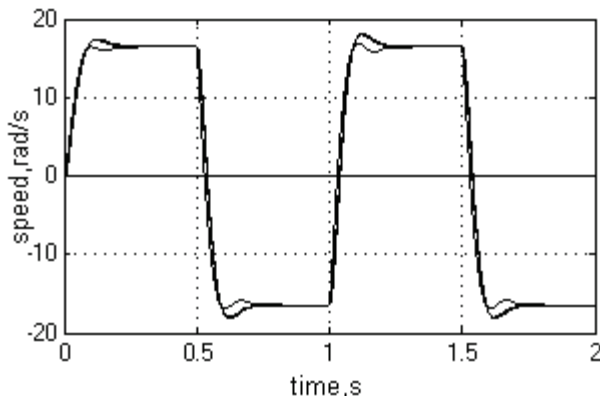

Fig. 6. Responses of loaded system to the bipolar pulse reference signal

These practically coinciding responses are obtained for the following cases: a)  $J_M = 0,4 \text{ kgm}^2$  and  $M_I = 0$ ; b)  $J_M = 0,1 \text{ kgm}^2$  and  $M_I = 4 \text{ Nm}$ ; c) b)  $J_M = 1 \text{ kgm}^2$  and  $M_I = 4 \text{ Nm}$ .

## Conclusions

1. The possibility of inertia moment observer application for acting load influence compensation on static characteristics of DC drive with P mode speed controller is investigated in this paper.
2. It is shown that in acceleration/deceleration phases of electric drive inertia moment observer can be used as speed controller gain corrector ensuring invariance of dynamic features in changing inertia moment conditions, in the steady state it can be used for static error provoked by acting load compensation.
3. Static accuracy and stability of the system is defined by dead zone of nonlinear element of observer, interrupting increasing of the gain of speed controller, when speed error  $e$  reaches predefined value.

## References

1. Dumont. G. ECE-54 - Adaptive control. University of British Columbia. 2006. p 41.
2. Vichai S., Hirai S., Komura M., Kuroki S. Hybrid Control-based Model Reference Adaptive Control // Electronics and Electrical Engineering. – Kaunas: Technologija, 2005. – No. 3(59). – P. 5–8.
3. Šulčius N., Geleževičius V. A. Investigation of Velocity Control System with Programmable Variable Structure Controller // Electronics and Electrical Engineering. – Kaunas: Technologija, 2007. – No. 5(77). – P. 53–56.
4. Борцов Ю. А., Поляков Н. Д., Путов В. В. Электромеханические системы с адаптивным и модальным управлением. Энергоатомиздат. Л. 1984. 215 с.

Received 2009 11 29

V. A. Geleževičius. Compensation of Acting Load Influence on Static Characteristics of Electric Drive by using Inertia Moment Observer // Electronics and Electrical Engineering. – Kaunas: Technologija, 2010. – No. 3(99). – P. 53–56.

The possibility of acting load influence on static characteristics of DC drive compensation by using inertia moment observer is investigated. It is demonstrated that in dynamic state of the drive observer identifies inertia moment of the moving part and gives a signal for speed controller gain correction for quantitative optimum condition ensuring. In the steady state of the drive the observer serves as speed error provoked by acting load minimisation by means of speed controller gain increasing. Modeling results of the system are presented. Ill. 6, bibl.4 (in English; summaries in English, Russian and Lithuanian).

V. A. Гяляжвявичус. Компенсация влияния момента нагрузки на статические характеристики электропривода с применением наблюдателя момента инерции // Электроника и электротехника. – Каунас: Технология, 2010. – №. 3(99). – С. 53–56.

Исследована возможность использования наблюдателя момента инерции для компенсации влияния момента нагрузки на статические характеристики электрического привода. Показано, что в динамическом режиме наблюдатель является фильтром момента инерции и формирует сигнал коррекции коэффициента усиления с целью обеспечения технического оптимума системы. В установившемся режиме наблюдатель используется для минимизации статической ошибки скорости нагруженного привода путем увеличения усиления регулятора скорости. Представлены результаты моделирования системы. Ил. 6, библи. 4 (на английском языке; рефераты на английском, русском и литовском яз.).

V. A. Geleževičius. Apkrovos įtakos elektros pavaros statinėms charakteristikoms kompensavimas naudojant inercijos momento stebėtuvą // Elektronika ir elektrotechnika. – Kaunas: Technologija, 2010. – Nr. 3(99). – P. 53–56.

Nagrinėjama galimybė inercijos momento stebėtuvą panaudoti apkrovos momento įtakai kompensavimo elektros pavaros statinėms charakteristikoms nustatyti. Parodyta, kad dinaminio režimo stebėtuvas veikia kaip inercijos momento filtras, formuojantis greičio regulatoriaus perdavimo koeficiento koregavimo signalą, garantuojantį kiekybinio optimumo sąlygą, kintant pavaros inercijos momentui. Pavarai veikiant statiniu režimu, stebėtuvas naudojamas apkrovos momento sąlygojamai greičio paklaidai minimizuoti, didinant greičio regulatoriaus stiprinimą. Pateikti sistemos modeliavimo rezultatai. Il. 6, bibl. 4 (anglų kalba; santraukos anglų, rusų ir lietuvių k.).

DOI: 10.5755/j02.eie.9905