

Evaluation of the Microstrip Lines Connectors in the Meander Delay Line Model

A. Gurskas, V. Urbanavičius, R. Martavičius

Department of Electronic Systems, Vilnius Gediminas Technical University,

Naugarduko str. 41-423, LT-03227 Vilnius, Lithuania, phone. +370 5 2744766, e-mail: antanas.gurskas@el.vgtu.lt

Introduction

The meander microstrip delay lines (MMDL) are widely used for pulse signals synchronization [1], for designing analogue and digital filters [2], small-sized antennas [3], resonators [4] and other devices [5], [6]. Design of the MMDL (Fig.1, (a)) consists of dielectric substrate with one side covered by a solid conductive layer that carries out the electric shield function and the signal conductor on the other side, having the meander form.

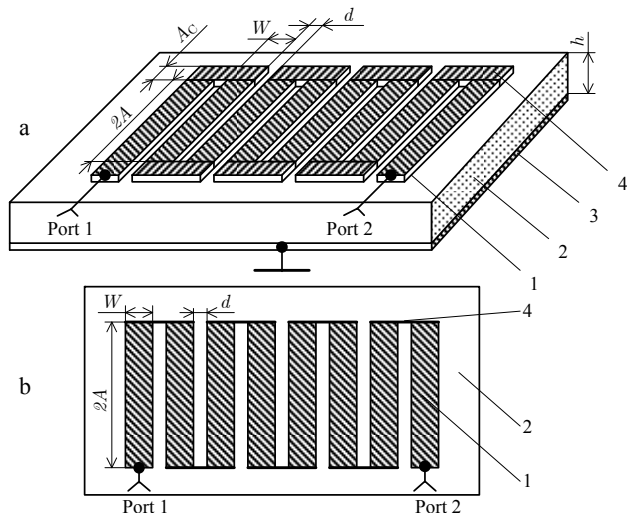

Fig. 1. The design (a), and physical model (b) of the microstrip meander delay line: 1 – strips of the meander conductor; 2 – dielectric substrate; 3 – conductive shield; 4 – strip connectors

Theoretical methods used for analysis of MMDLs can be conditionally united in two groups: analytical and computational or numerical. Analytical methods are based on the strict solution of the Maxwell's equations and application of the specific boundary conditions. The group of the analytical methods also includes the approached methods of analysis with deduced sophisticated equations describing behavior of specific MMDL with set of conditions and limitations of operation. A physical model in such methods may be created using microstrip multiconductor line which parameters in the cross-section plane are the same as MMDL. The part of multiconductor

line of length $2A$ is “cut out” in this case and neighboring conductors are connected using the infinite thin connectors. Boundary conditions of voltages and currents on the neighboring conductors of the multiconductor line are taken into consideration connecting conductors into meander path (Fig. 1, (b)). MMDLs are investigated using analytical methods in [7]–[9].

Recently numerical methods became popular (e.g., the method of moments – MoM [10], and the method of finite differences in time domain [11]) for simulation and analysis of MMDLs. Numerical methods allow us to obtain accurate characteristics of sophisticated electrodynamic systems and microwave devices. However, the duration of calculations can reach tens of hours even if modern workstations are used [12].

The hybrid methods (joining numerical and analytical) are used in practice in order to accelerate calculations of characteristics and preserve the accuracy of calculations [13], [14].

The paper is dedicated to specify MMDL model to make calculations using S matrix method more accurate.

Section “The model” in the paper describes the specified model of the MMDL. The investigated model of the MMDL and the results of its simulation and experimental measurement are presented in the following sections and the conclusions are formulated.

The model

The example of using of S matrix technique for calculation of the phase delay time for the MMDL was described in [15]. There was shown that calculated phase delay time differs from measured values in low frequency range by 3 % and it was much better than the calculation result using analytical method (analytically calculated values differ from measured results by 5 %). However in this model influence of microstrip line segments (connectors) connecting neighboring parallel strips of meander conductor wasn't evaluated. Moreover, verification of the model was done comparing calculated results with one fabricated MMDL prototype only.

Actually this is enough for the model preliminary estimation merely.

On the other hand there were attempts to evaluate influence of these segments analytically [16]. The main result of this evaluation was analytically shown increase of phase delay time when the model of MMDL was appended by lumped capacitances or short segments of microstrip lines in the space of short junction between neighboring meander strips. The main idea of this article is to append MMDL S matrix mathematical model [15] by lumped capacitances (first step) and input impedances of short microstrip lines segments (second step) as it was done analytically in [16].

Conformal mapping equations were used during the investigations (for calculation of capacitance per unit length of the multiconductor line parameters in case of odd and even excitation) and S matrix method for calculation of phase delay time of the MMDL. Experimentally phase delay time was measured by the method of π points. With the purpose of achievement of the greatest reality the calculated values of the phase delay time also were defined by the π points technique. For this purpose the global $ABCD$ matrix of the MMDL was calculated and input voltage response in the frequency domain of the open/shorted delay line were found.

MMDL topology pictures and proposed models are presented in Fig. 2.

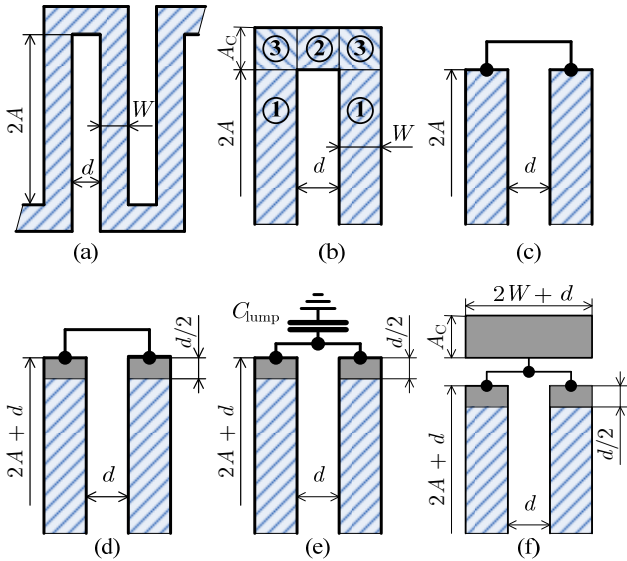

Fig. 2. Meander edge models: (a) – MMDL topology; (b) – designation by zones of the meander edge; (c) – simple model of the meander edge; (d) – model that evaluated zone ② by extending meander strips ①; (e) – the model (d) is appended by evaluation of zones ③ using lumped capacitance; (f) – model (d) appended by input complex admittance of the microstrip line segment made from topology of zones ② and ③

In the topology of the MMDL the meander edge of two neighboring strips and connector (Fig. 2 (a)) can be designated into zones ①, ② and ③ (Fig. 2 (b)). The simple model of the MMDL (Fig. 2 (c)) does not evaluate zones ② and ③ of the connector and is fairly accurate if length of meander strips is much larger than distance

between strips and, hence, time delay caused by the meander strips also will be larger than connectors delay

$$2A \gg d. \quad (1)$$

But height $2A$ of some MMDLs does not satisfy requirements of equation (1). Therefore it was worked on evaluation of the zones ② and ③.

The first approach in the way of getting better calculations accuracy with respect to measurements was expanding the height of the meander strips $2A$ (dark segments in the picture Fig. 2 (d)). Thus we compensated the path of the wave traveling between neighboring meander strips assuming that wave traveling conditions in this area are the same as along of the meander strips.

Next step reducing the difference between calculations and measurements was to append to the previous model (Fig. 2 (d)) lumped capacitances calculated as parallel plates capacitors of two square zones ③:

$$C_{\text{lump}} = (\varepsilon_0 \varepsilon_r W^2) / h, \quad (2)$$

where ε_0 – electrical constant; ε_r , h – correspondently dielectric permittivity and height of the substrate. This model is presented in Fig. 2 (e). We should take into account the fact that the parallel plates capacitor formula (2) does not evaluate electrical field scattering on the capacitor edges, so we still can expect better calculation accuracy in case of evaluation of this scattering.

Another way of evaluation of connectors is to analyze this topology part as input impedance of the short microstrip line segment with the open end (see Fig. 2 (f)). The input admittance of lossless microstrip line segment with the open end has complex value

$$\dot{Y}_{\text{IN}} = Y_0 \coth(j\beta A_C), \quad (3)$$

where Y_0 , β , and A_C correspondently are the characteristic admittance, phase constant, and length of the microstrip segment. As shorter the line is, the more similar line behaves as frequency independent lumped capacitance (Fig. 2 (e)). This lumped capacitance can be calculated as

$$C_{\text{lump}} = Y_0 (A_C \cdot k_d) / c_0, \quad (4)$$

where A_C – the length of the microstrip line segment; k_d – a delay factor of the short microstrip line segment; c_0 – the speed of light in free space.

MMDL scattering matrix calculation technique refers to creation of the internal junction matrix describing the meander topology. The meaning of each i and j element in the matrix corresponding to i and j meander topology element and is equal to one if there is no reflection between corresponding elements in the topology. In case of any reflection in the topology exist – the corresponding element of this junction matrix expressed as a function of complex normalized reflection coefficient and looks like

$$g_{i,j} = 1 / (1 + \dot{Y}_{\text{lump}}), \quad (5)$$

where i and j – the indexes of internal junction matrix elements; \dot{Y}_{lump} – lumped admittance of additional circuit in each meander pace of MMDL topology. All other junction matrix elements are equal to zero. In case of lumped capacitance this admittance is calculating as

$$\dot{Y}_{\text{lump}} = j2\pi f C_{\text{lump}}, \quad (6)$$

or

$$\dot{Y}_{\text{lump}} = \dot{Y}_{\text{IN}} \quad (7)$$

in case of very short ($A_C \ll 2A$) microstrip lines segment. Calculation results are presented in the following section.

The investigated MMDL

The layout of the experimental MMDL prototype is presented in Fig. 3.

It contains conductive meander path consisting of 67 meander paces. The meander conductor is formed on the dielectric substrate with the thickness $h = 0.46$ mm and the dielectric permittivity $\epsilon_r = 7.3$. Thickness of the meander conductor on the substrate is $t = 10 \mu\text{m}$.

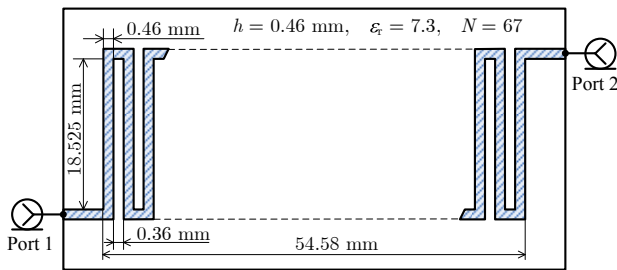

Fig. 3. The topology view of the experimental MMDL prototype

The pass band of the MMDL is specified by the phase-frequency distortions [8] so that main attention during the MMDL investigation was focused on the phase delay time versus frequency. Unfortunately truthfulness of the comparisons of experimentally measured and calculated characteristics is limited due to manufacturing inaccuracies both meander topology and substrate material characteristics (its thickness and permittivity) and due to the measurement inaccuracies. For overcoming this problem i.e. that results of measurements and calculations could be compared more objectively it is necessary to design, manufacture and investigate the number of the MMDL prototypes.

Comparison of simulation and measurement results

Calculated and measured results are presented in Fig. 4 and compared in Table 1. Relative difference between simulated and measured time delay is evaluated by

$$\delta t_{d100\text{MHz}} = \left(t_{d100\text{MHz}}^{(M)} - t_{d100\text{MHz}}^{(P)} \right) 100\% / t_{d100\text{MHz}}^{(P)}, \quad (8)$$

where $t_{d100\text{MHz}}^{(P)}$ and $t_{d100\text{MHz}}^{(M)}$ are the time delay of MMDL prototype, and specific MMDL model correspondently, at the 100 MHz frequency.

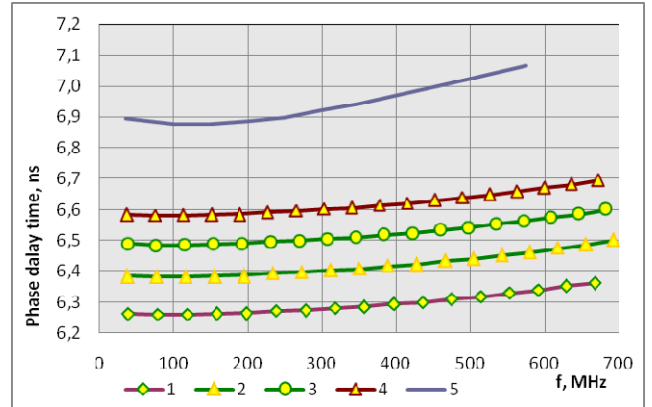

Fig. 4. The phase delay time of the MMDL (the topology is shown on Fig. 3) versus frequency: 1 – calculated according to simplified model, presented on Fig. 2 (c); 2 – calculated using the model shown on Fig. 2 (d); 3 – calculated using the model shown on Fig. 2 (e); 4 – calculated using the model shown on Fig. 2 (f); 5 – experimentally measured result

Table 1. Comparison of the simulation and measurement results

Model of MMDL	$t_{d100\text{MHz}}$ (ns)	$\delta t_{d100\text{MHz}}$ (%)
MMDL prototype	6.88	–
Fig. 2 (f)	6.58	4.36
Fig. 2 (e)	6.48	5.81
Fig. 2 (d)	6.38	7.23
Fig. 2 (c)	6.26	9.01

Initially calculations were started from the simplified model of MMDL (Fig. 2 (c)), without any evaluation of the meander edge and connector between two neighboring strips. Calculations (curve 1 in Fig. 4) were made according to the method described in [15]. Inaccuracy between calculated and measured results was got 9%.

Calculated curve 2 in Fig. 4 is gotten using the model of extended meander strips (Fig. 2 (d)) reduced calculations inaccuracy to 7.2%.

Curve 3 in Fig. 4 demonstrates extra evaluation of square zones ③ in the model shown on Fig. 2 (e). Inaccuracy was got 5.8%.

Finally, model (Fig. 2, (f)) appended by input complex admittance of the microstrip line made from zones ② and ③ has got the best calculation results (curve 4 in Fig. 4). Inaccuracy between calculated and measured results – 4.4%.

Conclusion

Calculated phase delay time of the MDDL usually is less than measured in all frequency range. Evaluation of MMDL meander edge between two neighbor strips can significantly increase calculated phase delay time and as a result increase calculation accuracy. Inaccuracy of calculated and measured phase delay time depends on the method of evaluation and on the topology of the MMDL. In case of investigated MMDL proposed evaluation method allows to increase calculated phase delay time and

reduce inaccuracy from 9 % to 4.4 %. The remained rather big difference between calculated and measured values we presume mainly due to dielectric substrate permittivity deflection which is under the control.

References

1. Zhou W., Ou X., Zhou H., et al. A Time interval measurement technique based on time and space relationship processing // International Frequency Control Symposium and Exposition, IEEE. – 2006. – P. 260–266.
2. Vincent P., Culver J., Eason S. Meandered line microstrip filter with suppression of harmonic passband response // Microwave Symposium Digest, IEEE MTT-S International. – 2003. – Vol. 3. – P. 1905–1908.
3. Taher M. K. Small size multiband meander line antenna for wireless applications // Antennas and Propagation Conference LAPC 2008. – 2008. – P. 401–404.
4. Tang W. X., et al. A meander line resonator to realize negative index materials // Antennas and Propagation Society International Symposium AP-S 2008. – IEEE, 2008. – P. 1–4.
5. Tharp J. S., Lopez-Alonso J. M., Ginn J. C., et al. Demonstration of a single layer meander line phase retarder at IR // Antennas and Propagation Society International Symposium, IEEE. – 2006. – P. 829–832.
6. Chen C., Li C., Huang B., et al. Ring-based triple-push VCOs with wide continuous tuning ranges // IEEE Transaction on MTT. – 2009. – Vol. 57, No. 9. – P. 2173–2192.
7. Martavičius R. Electrodynamic plain retard systems for wide band electronic devices // Vilnius: Technika, 1996. – 264 p.
8. Štaras S., Vainoris Z., Martavičius R., et al. Broadband signal paths for travelling wave oscilloscope cathode-ray tubes / Vilnius: Technika, 1993. – 360 p. (in Russian).
9. Nickelson L., Asmontas S., Tamosiuniene M., Shugurov V. Numerical study of open slot lines with asymmetrically placed strip conductor in 37.5 – 78 GHz frequency band // International Journal of Infrared and Millimeter Waves. – 2003. – Vol. 24, No. 11. – P. 1913–1923.
10. Rubin B. J., Singh B. Study of meander line delay in circuit boards // IEEE Transactions on MTT. – 2000. – Vol. 48, No. 9. – P. 1452–1460.
11. Daškevičius V., Skudutis J., Štaras S. Simulation of the inhomogeneous meander line // Electronics and Electrical Engineering. – Kaunas: Technologija, 2007. – No. 2(74). – P. 37–40.
12. Cheng Q. S., Bandler J. W., Koziel S. Combining coarse and fine models for optimal design // IEEE Microwave Magazine. – 2008. – Vol. 9, No. 1. – P. 79–88.
13. Burokas T., Daskevicius V., Skudutis J., Staras S. Simulation of the wide-band slow-wave structures using numerical methods // The International Conference on Computer as a Tool, EUROCON 2005. – 2005. – Vol. 1. – P. 848–851.
14. Urbanavicius V., Gurskas A., Martavicius R. Simulation of the Meander Delay Line Using the Hybrid Method // Electronics and Electrical Engineering. – Kaunas: Technologija, 2009. – No. 2(90). – P. 6–9.
15. Gurskas A., Jurevicius V., Kirvaitis R., et al. Application of Scattering Matrices in Investigation of Electrodynamic Systems // Electronics and Electrical Engineering. – Kaunas: Technologija, 2002. – No. 4(39). – P. 7–12.
16. Gurskas A., Martavicius R. Influence of contacting squares to the properties of Meander Microstrip Delay Lines // Radioelectronics. – Vilnius. – 1988. – Vol. 24, No 3. – P. 53–58.

Received 2009 12 08

A. Gurskas, V. Urbanavičius, R. Martavičius. Evaluation of the Microstrip Lines Connectors in the Meander Delay Line Model // Electronics and Electrical Engineering. – Kaunas: Technologija, 2010. – No. 3(99). – P. 39–42.

The model of the Meander Microstrip Delay Line (MMDL) evaluating neighbor meander microstrips junction is presented. Model of the MMDL is based on scattering matrix method. Consecutive transition from simplest MMDL model without evaluation of meander microstrip connectors to sophisticated model, which evaluates the meander microstrip connectors by open microstrip line segment. The intermediate models are evaluating the meander microstrip connectors by extending the length of the meander strips and by lumped capacitances. It is found that in case of primitive model calculated MMDL phase delay time usually is lesser than experimentally measured, but in case of sophisticated model, calculated phase delay time rises. This rise depends on the MMDL meander topology and on the technical characteristics of the dielectric substrate. Adequacy of the proposed model was checked by the software written by authors. The carried out calculations have shown good coincidence with the experimentally measured results. Ill. 4, bibl. 16 (in English; summaries in English, Russian and Lithuanian).

A. Гурскас, В. Урбанавичюс, Р. Мартавичюс. Оценка влияния сегментов микрополосковых соединителей в модели меандровой линии задержки // Электроника и электротехника. – Каunas: Технология, 2010. – № 3(99) – С. 39–42.

Представлена модель меандровой микрополосковой линии задержки (ММЛЗ), учитывающая соединения соседних микрополосок меандрового проводника. ММЛЗ моделируется гибридным методом на основе матриц рассеяния. Представлен последовательный переход от простейшей модели ММЛЗ, не учитывающей зон соединения соседних микрополосок, до сложной, в которой зоны соединения соседних микрополосок моделируются отрезками разомкнутых микрополосковых линий. В промежуточных вариантах модели зоны соединения соседних микрополосок предложено моделировать пропорциональным удлинением меандровых полосок и сосредоточенной емкостью. Показано, что в случае примитивной модели рассчитанная величина фазового времени задержки обычно меньше измеренной, а в случае предложенной модели рассчитанная величина увеличивается и приближается к измеренной. Это приближение зависит как от топологии ММЛЗ так и от характеристик диэлектрической подложки. Адекватность модели проверена авторами созданным программным обеспечением. Проведенные расчеты показали хорошее совпадение рассчитанных результатов с измеренными. Ил. 4, библи. 16 (на английском языке; рефераты на английском, русском и литовском яз.).

A. Gurskas, V. Urbanavičius, R. Martavičius. Mikrojuostelinų jungiklių įvertinimas meandrinės vėlinimo linijos modelyje // Elektronika ir elektrotechnika. – Kaunas: Technologija, 2010. – Nr. 3(99). – P. 39–42.

Pateiktas mikrojuostelinės meandrinės vėlinimo linijos (MMVL) modelis, įvertinantis meandrą sudarančių gretimų strypų sujungimo zonas. MMVL modeliuojama sklaidos matricių metodu. Pateiktas nuoseklus perėjimas nuo paprasčiausio MMVL modelio, neįvertinančio sujungimo zonų, iki sudėtingo, kurio sujungimų zonas modeliuojamos atvirų mikrojuostelinų linijų atkarpomis. Tarpiniuose modelio variantuose strypų sujungimo zonas siūloma modeliuoti proporcingu daigialaidės linijos juostelių pailginimu ir sutelktomis talpomis. Parodyta, kad taikant primityvų modelių apskaičiuota fazinio vėlinimo laiko skaičiuota vertė paprastai būna mažesnė už išmatuotą, o naudojant siūlomą modelį skaičiuota fazinio vėlinimo laiko vertė padidėja. Šis padidėjimas priklauso tiek nuo

MMVL konstrukcijos, tiek nuo dielektrinio pagrindo techninių charakteristikų. Siūlomo modelio adekvatumas patikrintas autorių sukurta programine įranga. Skaičiavimai parodė, kad gauti rezultatai gerai sutampa su eksperimentiškai išmatuotais. Il. 4, bibl. 16 (anglų kalba; santraukos anglų, rusų ir lietuvių k.).

DOI: 10.5755/j02.eie.9902