

## Three-Phase Motor Control using Modified Reference Wave

C. Aghion, O. Ursaru, M. Lucanu

Technical University "Gheorghe Asachi" of Iași, Blvd Carol I, No.11, Romania, phone: +40.232.270.021 int.285

e-mail: aghion@etc.tuiasi.ro, ovidiu@etc.tuiasi.ro, mlucanu@etc.tuiasi.ro

### Introduction

This paper describes the implementation of a modified reference wave using discontinuous pulse width modulation (DPWM-S2) technique.

DPWM-S2 [1] command technique is a high performance computational control method, having as a main advantage the reduction of the number of commutations of the power transistors within the three-phase inverter, as compared to other modulation techniques, e.g. Sinusoidal Pulse Width Modulation (SPWM) [2], Space Vector Modulation (SVM) [3], etc. The number of commutations is reduced as, considering equations (1) for two intervals of time (out of six), some transistors are in continuous conduction, and power losses in commutation should be in theory by 1/3 smaller if SPWM or SVM techniques were used. With a reduced number of commutations, power losses on the transistors are decreasing, caloric power is decreasing too and, as a result, smaller heat-sinks are needed on the same transistors.

### Theoretical considerations regarding the modulation signal

The main equations of the DPWM-S2 signal are presented in (1) and the mathematical representation is shown in Fig. 1.

$$s_2 = \begin{cases} 1, & 0 \leq \omega_m t \leq \pi/3, \\ \sqrt{3}m_a \cos \omega_m t + m_a \sin \omega_m t - 1, & \pi/3 \leq \omega_m t \leq 2\pi/3, \\ \sqrt{3}m_a \cos \omega_m t - m_a \sin \omega_m t + 1, & 2\pi/3 \leq \omega_m t \leq \pi, \\ -1, & \pi \leq \omega_m t \leq 4\pi/3, \\ \sqrt{3}m_a \cos \omega_m t + m_a \sin \omega_m t + 1, & 4\pi/3 \leq \omega_m t \leq 5\pi/3, \\ \sqrt{3}m_a \cos \omega_m t - m_a \sin \omega_m t - 1, & 5\pi/3 \leq \omega_m t \leq 2\pi. \end{cases} \quad (1)$$

Fig. 2 shows the waveforms of the modulator signals ( $s_{2a}$ ,  $s_{2b}$  and  $s_{2c}$ ) obtained for the DPWM-S2 technique and the control signals for all six transistors within the power inverter.

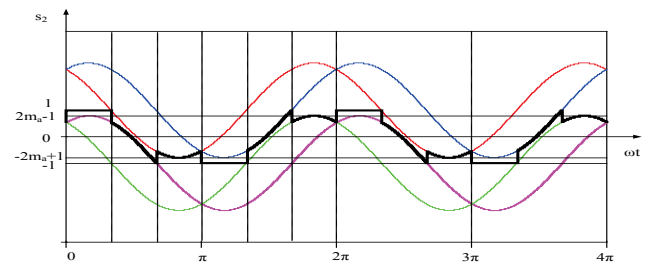

Fig. 1. The modulator signal DPWM-S2

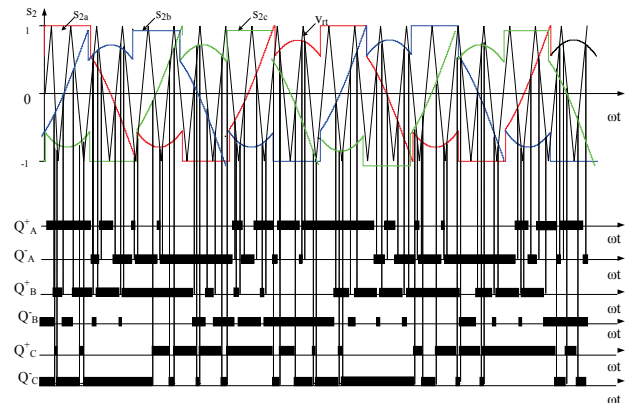

Fig. 2. Waveforms of the modulator and control signals for all six transistors

Fig. 3 shows the power inverter schematics used for the simulation.

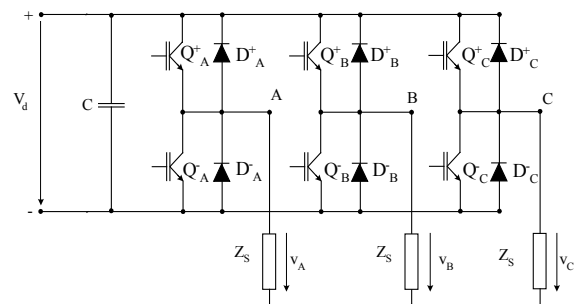
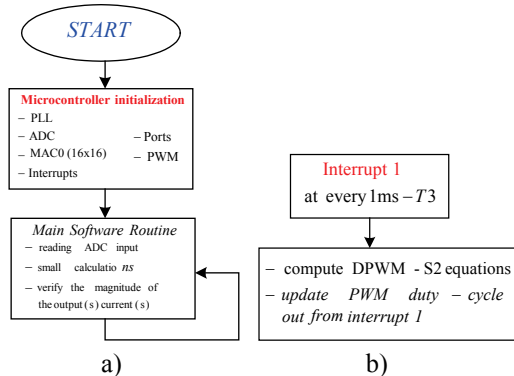

Fig. 3. Power inverter architecture

## Command and Control Algorithm

The DPWM-S2 software takes into consideration equations (1) and is suited for C8051F120 microcontroller made by Silicon Laboratories. The main flowchart of the control software is shown in Fig. 4a Fig. 4b shows the flowchart of the T3 Timer interruption (Service Routine Interruption), where the main equations are solved.



**Fig. 4.** Command and control algorithm: a – software control flowchart; b – flowchart of Interrupt 1

The first step is the microcontroller initialization (Input/Output Ports, ADC, PLL, Timers, PWM, etc.), the second step is the execution of the main software routine, written in C language, where the value of the Analog to Digital Converter (ADC) is continually read. This value is useful for the calculation of the magnitude of the modulator wave for the desired signal. The software also contains an interrupt routine:

Interrupt 1 appears at every 1ms because the Timer T3 surpasses itself. In this routine all three command signals are computed (with  $120^\circ$  phase-shift between them); there are three signals because it is necessary to command transistors  $Q_A^+$ ,  $Q_B^+$  and  $Q_C^+$ , and for  $Q_A^-$ ,  $Q_B^-$  and  $Q_C^-$  transistors, the command signals are obtained by the complementation of the original signals.

## Software Control

The command software is written in C language, applied to C8051F120 microcontroller. The software routine for the calculation of the PWMA signals ( $s_{2a}$ ,  $s_{2b}$  and  $s_{2c}$ ) is shown below. It should be taken into consideration that all these calculations are made in Interrupt 1 routine (having a lower priority), which is executed at every 1ms when Timer T3 surpasses itself. The necessary computing time is approximately  $400\mu s$ , performance obtained using MAC 16x16 (Multiply and Accumulate) block and the high working speed of the microcontroller (100MHz-100MIPS / millions of instructions per second).

```
void Timer3_ISR (void) interrupt 14
// at every 1ms
{
    unsigned char SFRPAGE_SAVE = SFRPAGE;
    gigi();
    SFRPAGE = TMR3_PAGE;
    TF3 = 0;
    SFRPAGE = SFRPAGE_SAVE;
}
```

```
}
//-----
// Compute modulation signals
//-----

void gigi(void)
{
    signed char s;          // signed sine
    unsigned char o;       // output value
    unsigned int p;        // 16 bit product

    unsigned char SFRPAGE_SAVE = SFRPAGE;

    float f0, f1, f2, tr0, tr1, tr2;
        Sum += (freq << 6);
    q0 = (Sum >> 8);
    tr0 = (q0/40.6);

    if(!reverse)
    {
        tr1 = tr0 + xx1;
        tr2 = tr0 + xx2;
    }
    else
    {
        tr2 = tr0 + xx1;
        tr1 = tr0 + xx2;
    }

    SFRPAGE = PCA0_PAGE;
    f0 = s3(tr0);
    s = f0*0x7F;
    p = amplitude * (signed int)s;
        //multiply by v
    o = p>>8;          // throw away low byte
    o += 0x80;        // center sinewave at 50%
    PCA0CPH0 = o;

    f1 = s3(tr1);
    s = f1*0x7F;
    p = amplitude * (signed int)s;
        //multiply by v
    o = p>>8;          // throw away low byte
    o += 0x80;        // center sinewave at 50%
    PCA0CPH1 = o;

    f2 = s3(tr2);
    s = f2*0x7F;
    p = amplitude * (signed int)s;
        //multiply by v
    o = p>>8;          // throw away low byte
    o += 0x80;        // center sinewave at 50%
    PCA0CPH2 = o;
    SFRPAGE = SFRPAGE_SAVE; }

//-----
// Compute DPWM-S2 signal
//-----

float s3(float tr)
{
    float dpwma;

    if(tr<=1.046 && tr>0)
    {
        dpwma = 1;
    }

    if(tr<=2.093 && tr>1.046)
    {
        dpwma = (sqr3*ma*cos(tr)+ma*sin(tr)) - 1;
    }
    if(tr<=3.151 && tr>2.093)
    {
        dpwma = (sqr3*ma*cos(tr)-ma*sin(tr)) + 1;
    }
    if(tr<=4.186 && tr>3.151)
    {

```

```

        dpwma = -1;
    }

    if(tr<=5.233 && tr>4.186)
    {
        dpwma = (sqr3*ma*cos(tr)+ma*sin(tr)) + 1;
    }

    if(tr<=6.28 && tr>5.233)
    {
        dpwma = (sqr3*ma*cos(tr)-ma*sin(tr)) - 1;
    }

    if(tr<=1.046+6.28 && tr>0+6.28)
    {
        dpwma = 1;
    }

    if(tr<=2.093+6.28 && tr>1.046+6.28)
    {
        dpwma = (sqr3*ma*cos(tr)+ma*sin(tr)) - 1;
    }

    if(tr<=3.151+6.28 && tr>2.093+6.28)
    {
        dpwma = (sqr3*ma*cos(tr)-ma*sin(tr)) + 1;
    }

    if(tr<=4.186+6.28 && tr>3.151+6.28)
    {
        dpwma = -1;
    }

    if(tr<=5.233+6.28 && tr>4.186+6.28)
    {
        dpwma = (sqr3*ma*cos(tr)+ma*sin(tr)) + 1;
    }

    if(tr<=6.28+6.28 && tr>5.233+6.28)
    {
        dpwma = (sqr3*ma*cos(tr)-ma*sin(tr)) - 1;
    }

    return dpwma;
}

```

### Simulation and experimental results

After implementing the above software on the microcontroller, the signals  $s_{2a}$  and  $s_{2b}$  are obtained and shows in Fig. 5.

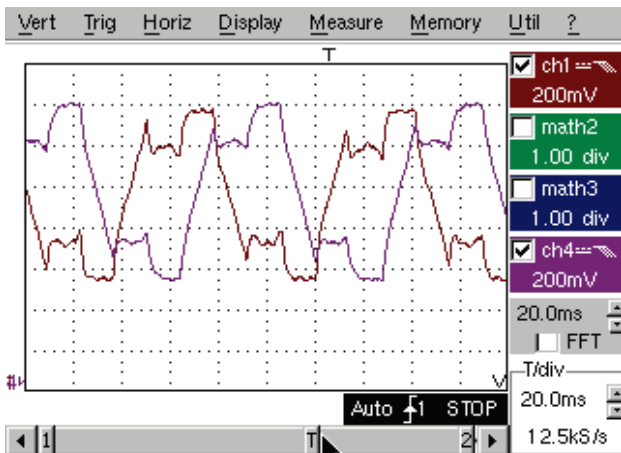

Fig. 5. Modulation signals  $s_{2a}$  and  $s_{2b}$  obtained by measurement

Fig. 6 shows the waveforms of the command signals for  $Q_A^+$  and  $Q_B^+$  transistors within the three-phase inverter. It is important to mention that the modulation was a triangular modulation wave with 17.25KHz carrier frequency.

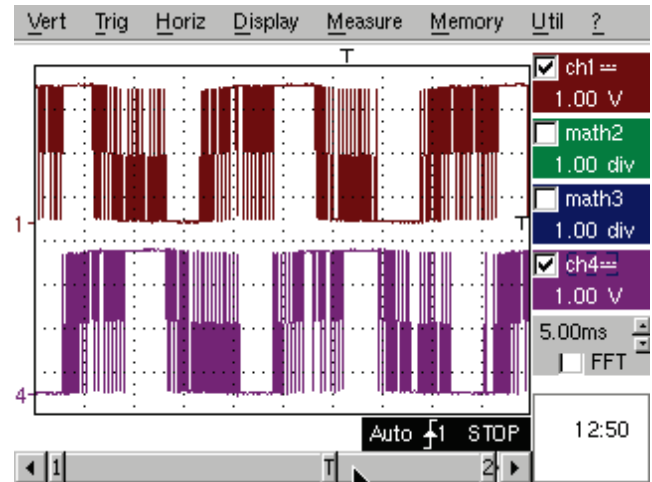

Fig. 6. Waveforms from the oscilloscope of the command signals for  $Q_A^+$  and  $Q_B^+$  transistors

Considering that the supply voltage of the three-phase is 305V and the output impedance is of 0.37 KW for the simulations and on the practical stand, we obtain the following.

Fig. 7 shows on the left side the line to line voltage between A and B phases read on the oscilloscope, and the harmonic content of this voltage is presented below. On the right side, is presented the line to line voltage between A and B phases, obtained by simulations, and the harmonic spectrum of the line to line voltage between A and B phases, obtained also by simulations.

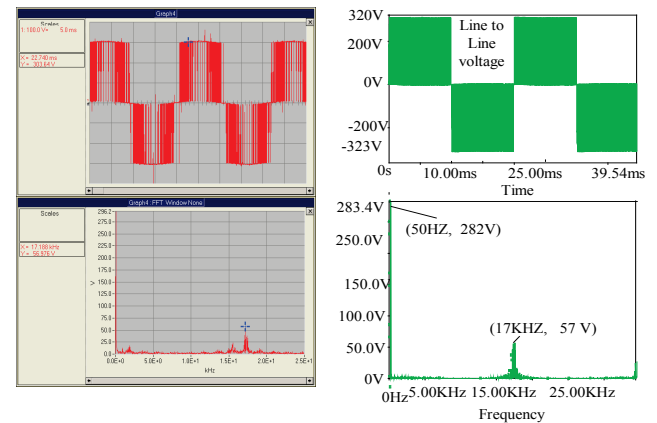
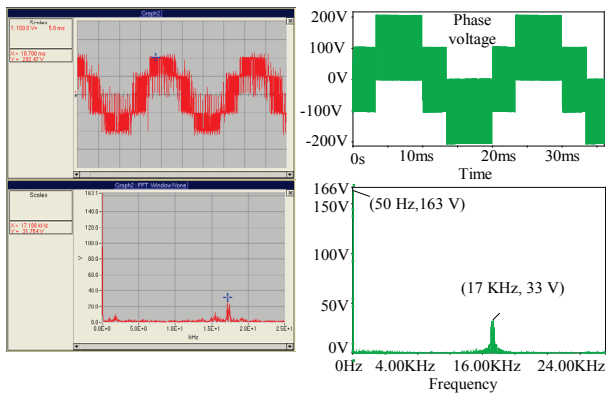

Fig. 7. – left side: waveforms and harmonic spectrum of the line to line voltage, obtained from oscilloscope  
– right side: waveforms and harmonic spectrum of the line to line voltage, obtained by simulations

Fig. 8 shows on the left side the phase voltage A, read on the oscilloscope, and the harmonic content of this voltage is presented below. On the right side, is presented the phase voltage A, obtained by simulations, followed by the harmonic spectrum of the phase voltage A, obtained by simulations.



**Fig. 8.** – left side: waveforms and harmonic spectrum of the phase voltage A, obtained from oscilloscope.

– right side: waveforms and harmonic spectrum of the phase voltage A, obtained by simulations

Fig. 9 shows on the left side the phase current A, read on the oscilloscope, and the harmonic content of this current is presented below. On the right side is presented the phase current A, obtained by simulations, followed by the harmonic spectrum of the phase current A, obtained by simulations.

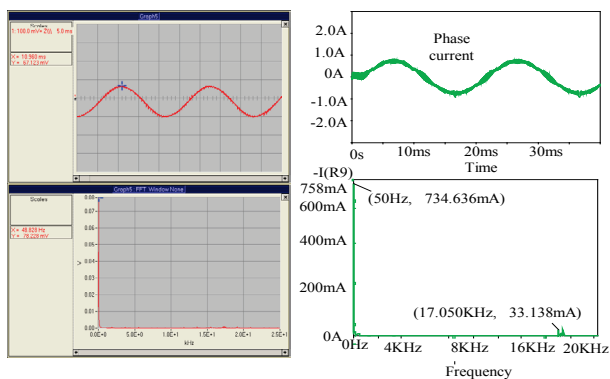

**Fig. 9.** – left side: waveforms and harmonic spectrum of the phase current A, obtained from oscilloscope

– right side: waveforms and harmonic spectrum of the phase current A, obtained by simulations

## Conclusion

This paper aims at implementing the DPWM-S2 algorithm using a microcontroller for three-phase inverter command. Although this DPWM-S2 technique is of high performance, we cannot say that this technique is the best (considering also the frequency response of the output voltage), but it offers a great advantage as it determines a reduction of the number of commutations of the power transistors within the three-phase inverter. This will lead to small power losses, increasing the efficiency of the inverter.

## References

1. **Hava A.** Carrier based PWM-VSI drives in the overmodulation region. PhD Thesis. – University of Wisconsin, Madison, 1998. – 360 p.
2. **Ursaru O., Aghion C., Lucanu M., Tigaeru L.,** Pulse Width Modulation Command Systems Used for the Optimization of Three Phase Inverters // *Advanced in Electrical and Computer Engineering Journal.* – Suceava, Romania. – Vol. 9. – No. 1/2009. – P. 22–27
3. **Bose K. B.,** Microcomputer Control of Power Electronics and Drive. – New York: IEEE Press, – 1987.
4. **Kácsor G., Špánik P., Dudrík J., Luft M., Szychta E.** Principles of Operation of Three-level Phase Shift Controlled Converter // *Electronics and Electrical Engineering.* – Kaunas: Technologija, 2008. – No. 2(82). – P. 69–74.
5. **Špánik P., Dobrucký B., Frivaldský M., Drgoňa P., Kurytník I.** Experimental Analysis of Commutation Process of Power Semiconductor Transistor's Structures // *Electronics and Electrical Engineering.* – Kaunas: Technologija, 2008. – No.2(82). – P. 75–78.
6. **Savickienė Z., Poška A. J.** Simplified Calculation of Linear Induction Drives Characteristics // *Electronics and Electrical Engineering.* – Kaunas: Technologija, 2007. – No. 5(77). – P. 15–18.
7. **Aghion C., Ursaru O., Lucanu M., Dimitriu L., Vornicu L.,** Software Control for PWMA // *International Symposium on Signals Circuits and Systems (ISSCS2007).* – Vol. 2. – P. 429–432. IEEE Catalog Number 07EX1678.
8. **Rata G., Rata M., Graur I., Milici D. L.,** Induction Motor Speed Estimator Using Rotor Slot Harmonics // *Advances in Electrical and Computer Engineering Journal.* – Suceava, Romania. – Vol. 9. – No. 1/2009. – P. 70–73.

Received 2009 12 29

**C. Aghion, O. Ursaru, M. Lucanu.** Three-Phase Motor Control using Modified Reference Wave // *Electronics and Electrical Engineering.* – Kaunas: Technologija, 2010. – No. 3(99). – P. 35–38.

This paper describes the implementation of a modified reference wave using discontinuous pulse width modulation DPWM-S2 technique. The number of commutations is reduced as, for two intervals of time (out of six), some transistors are in continuous conduction, and power losses in commutation should be in theory by smaller if SPWM or SVM techniques were used. Ill. 9, bibl. 8 (in English; abstracts in English, Russian and Lithuanian).

**Ц. Агхион, О. Урсару, М. Луцану.** Использование справочной волны для контроля трехфазного мотора // *Электроника и электротехника.* – Каунас: Технология, 2010. – № 3(99). – С. 35–38.

Описывается метод модуляции ширины импульса, когда применяется DRW-S2 справочной волны. В эксперименте число переключения транзисторов сохранен от 6 до 2. Дан теоретический анализ времени переключения на основе методов SPWM или SVM. Экспериментальные результаты переключения трехфазного мотора совпадает с теоретическими предпосылками. Ил. 9, библи. 8 (на английском языке; рефераты на английском, русском и литовском яз.).

**C. Aghion, O. Ursaru, M. Lucanu.** Trifazio variklio valdymas modifikuoto šaltinio banga // *Elektronika ir elektrotechnika.* – Kaunas: Technologija, 2010. – Nr. 3(99). – P. 35–38.

Aprašytas modifikuotos šaltinio bangos DPWM-S2 metodas, paremtas impulso pločio moduliacija. Tiriant tranzistorių persijungimų skaičius buvo sumažintas nuo 6 iki 2. Persijungimų metu kai kurie tranzistoriai išlieka pereinamosios būsenos. Teoriniu požiūriu persijungimo trukmė turi būti trumpesnė, jei taikomi SPWM ar SVM metodai. Il. 9, bibl. 8 (anglų kalba; santraukos anglų, rusų ir lietuvių k.).

DOI: 10.5755/j02.eie.9901