

State-feedback Control of a Current Source Inverter-based STATCOM

Gang Yao¹, LiXue Tao², LiDan Zhou¹, Chen Chen¹

¹ *Department of Electrical Engineering, Shanghai Jiao tong University
DongChuan Road #800, Shanghai, P. R. China, phone: +086 21 62932367;
e-mail: yaogangthh@sjtu.edu.cn*

² *Jiangsu Electronic power design institute, Nanjing.*

Introduction

In recent decades, the electric distribution systems are suffering from significant power quality (PQ) problems, which are characterized by low power factor, poor voltage profile, voltage fluctuations, voltage sag/swell, load unbalancing, and supply interruptions. These power quality issues have attracted attention to the researchers both in academic and industry. As a result, many power quality standards were proposed in [1], such as the IEEE 519-1992, IEEE Std.141-1993, IEEE Std.1159-1995 and IEC 1000-3-2, etc. Among all forms of the power quality issues, the voltage fluctuations or sag/swell problems were recognized as the most costly events in the modern assembly lines and commercial offices. On the other hand, the increasing power quality problems have stimulated a great potential for the industry to devise the power quality mitigation and compensation devices. For instance, the static synchronous compensator (STATCOM) are designed to compensate fundamental frequency reactive power component, moreover, the STATCOM also has the capability for voltage regulation for grid voltage at the common coupling point (PCC) by injecting or absorption a certain amount of reactive power. Hence the STATCOM received considerable attention due to the urgent requirement for tackling the voltage fluctuation problems.

Compared with the static var compensator (SVC), the STATCOM has advantages such as fast, continuous reactive power output ability, high efficiency and low harmonic distortion in the output current [2]. There are actually two different kinds of STATCOMs, classified by their inverter configuration: voltage source inverters (VSIs) and current source inverters (CSIs).

Nowadays, the pulse width modulated (PWM) three-phase voltage-source inverter (VSI) is the most common dc/ac power converter, extensively used in ac drive systems, ac uninterruptible power supplies and the active power filters, which has been operated in transmission or distribution power systems [2–8, 11]. Simple and robust, it is easy to control in the feed-forward voltage mode or feedback current mode. Wide ranges of the frequency and

magnitude of fundamental output voltage are attainable. Moreover, the VSIs, typically based on the fast-switching IGBTs, are not free of certain drawbacks, which include substantial switching losses, conducted and radiated electromagnetic interference (EMI).

The current source inverters (CSIs), typically, supplied from controlled rectifiers with close-loop current control, which can transfer the electric power in both directions and are characterized by a fast response to the phase command for the vector of output current. Due to large dc-link inductance and current control in the rectifier, the inherent protection from over-current, the power circuit of the CSI is simpler and more robust than that of the VSI. Meanwhile, the CSI topology offers a number of distinct advantages over VSI topology [9] as following: 1) directly controlling the output current of inverter; 2) implicit short-circuit protection, the output current being limited by the dc inductor; 3) high converter reliability, due to the unidirectional nature of the switches and the inherent short-circuit protection; 4) fast start-up, where no additional start-up rectifier is needed. In addition, unlike VSI STATCOM, the CSI STATCOM injects no harmonic into the ac network when it is operating at zero. These characters make the CSI a potential device for reactive power control.

The research on the CSI topology and its allocations in power systems has been discussed in detail [9-10]. When applied to STATCOM, the direct output of a CSI is a controllable ac current, whereas that of a VSI is a controllable ac voltage. In most transmission systems, under normal operating conditions, the current injected by STATCOM is a small percentage of the line current. Therefore, when CSI is applied, the current harmonics are very small. On the contrary, the VSI topology results larger voltage and current harmonic distortions. On the other hand, the dc energy storage element in CSI topology is an inductor, whereas in VSI topology is a capacitor, which means that the power loss and dc energy storage requirement of CSI is lower than that of VSI.

This paper is organized as follows: The mathematical linear modeling of the CSI-based STATCOM is presented

in Section 2. And the control strategies are presented in Section 3, where a decoupled state-feedback with PI controller is formulated and discussed in detail. In section 4, the performances of the STATCOM during the steady-state and responsibility to step changes in the reference values of the q -axis and dc-side current are evaluated by simulation tool PSCAD/EMTDC. Finally, Section 6 concludes this paper.

CSI-based STATCOM modeling

The topology of the CSI STATCOM presented in this paper is depicted in Fig.1. It is equal to be a controllable current source, which generates a 90° leading or lagging sinusoidal current with respect to the corresponding phase voltage. The differential equations for the system in the synchronous frame are derived as [6-8]:

$$\frac{d}{dt} \begin{bmatrix} i_{dc} \\ i_d \\ i_q \\ v_{cd} \\ v_{cq} \end{bmatrix} = \begin{bmatrix} \frac{R_{dc}}{L_{dc}} & 0 & 0 & -\frac{3M_d}{2L_{dc}} & -\frac{3M_q}{2L_{dc}} \\ 0 & -\frac{R}{L} & \omega_0 & \frac{1}{L} & 0 \\ 0 & -\omega_0 & -\frac{R}{L} & 0 & \frac{1}{L} \\ \frac{M_d}{C_s} & -\frac{1}{C_s} & 0 & 0 & \omega_0 \\ \frac{M_q}{C_s} & 0 & -\frac{1}{C_s} & -\omega_0 & 0 \end{bmatrix} \begin{bmatrix} i_{dc} \\ i_d \\ i_q \\ v_{cd} \\ v_{cq} \end{bmatrix} + \begin{bmatrix} 0 \\ -\frac{v_{sd}}{L} \\ \frac{v_{sq}}{L} \\ 0 \\ 0 \end{bmatrix}, \quad (1)$$

where ω_0 is fundamental frequency of the grid voltage. M_d and M_q are the control signals of CSI and can be expressed by

$$\begin{bmatrix} M_d \\ M_q \end{bmatrix} = M \begin{bmatrix} \cos \delta \\ \sin \delta \end{bmatrix}, \quad (2)$$

where M is the modulation index and δ is the phase angle of CSI output current. In order to simplify the analysis, assuming that the d-axis frame is coincided with direction of the space vector of the system voltage, i.e.,

$$\begin{bmatrix} v_{sd} \\ v_{sq} \end{bmatrix} = \begin{bmatrix} V_s \\ 0 \end{bmatrix}, \quad (3)$$

where V_s is the RMS value of phase voltage of the system.

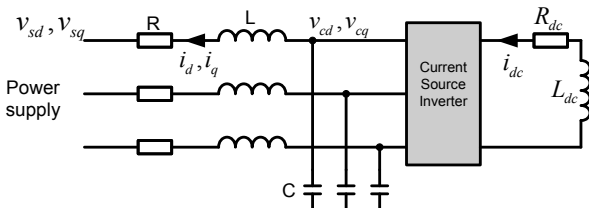

Fig. 1. The schematic of STATCOM based on CSI

It can be deduced from eq.(1) that the system is nonlinear due to the existence of variables $M_d v_{cd}$ and $M_q v_{cq}$. It is obvious that i_{dc} is the source of nonlinearity in the model of the CSC-based STATCOM. An alternate method

for describing the dynamics of i_{dc} is to use the active power balance equation. Neglecting the power loss in resistance R and the switches, the active power balance equation is

$$P_{ac} = P_{dc}, \quad (4)$$

The active power delivered by the ac source P_{ac} and the active power absorbed by the dc-side P_{dc} can be expressed as

$$P_{ac} = -\frac{3}{2} v_{sd} i_d, \quad (5)$$

$$P_{dc} = L_{dc} i_{dc} \frac{d}{dt} i_{dc} + R_{dc} i_{dc}^2. \quad (6)$$

Then the following expression can be derived:

$$L_{dc} i_{dc} \frac{d}{dt} i_{dc} + R_{dc} i_{dc}^2 = -\frac{3}{2} v_{sd} i_d, \quad (7)$$

which can be written as

$$\frac{d}{dt} (i_{dc}^2) = -\frac{2R_{dc}}{L_{dc}} (i_{dc}^2) - \frac{3v_{sd}}{L_{dc}} i_d. \quad (8)$$

In (8), i_{dc}^2 is taken as the state variable instead of i_{dc} , which can make the dynamic equation linear. Since i_{dc} does not change direction, it will not cause any technical problem to choose i_{dc}^2 as state variable. In the steady state, the range of variations of v_{sd} is very small, which can be equal to a constant. Therefore it is reasonable to treat (11) as a linear equation. In eq.(1), the input variables v_{cd} and v_{cq} are coupled with i_{dc} , therefore two new variables are defined to linearize the system. Note that

$$\begin{cases} i_{id} = M_d i_{dc} \\ i_{iq} = M_q i_{dc} \end{cases} \quad (9)$$

Submitting eqs.(3) and (9) into eq.(1), the resulting improved dynamic model of the STATCOM in matrix form can be derived as

$$\frac{d}{dt} \begin{bmatrix} (i_{dc}^2) \\ i_d \\ i_q \\ v_{cd} \\ v_{cq} \end{bmatrix} = \begin{bmatrix} -\frac{2R_{dc}}{L_{dc}} & -\frac{3V_s}{L_{dc}} & 0 & 0 & 0 \\ 0 & -\frac{R}{L} & \omega_0 & \frac{1}{L} & 0 \\ 0 & -\omega_0 & -\frac{R}{L} & 0 & \frac{1}{L} \\ 0 & -\frac{1}{C_s} & 0 & 0 & \omega_0 \\ 0 & 0 & -\frac{1}{C_s} & -\omega_0 & 0 \end{bmatrix} \begin{bmatrix} (i_{dc}^2) \\ i_d \\ i_q \\ v_{cd} \\ v_{cq} \end{bmatrix} + \begin{bmatrix} 0 & 0 \\ 0 & 0 \\ 0 & 0 \\ \frac{1}{C_s} & 0 \\ 0 & \frac{1}{C_s} \end{bmatrix} \begin{bmatrix} i_{id} \\ i_{iq} \end{bmatrix} + V_s \begin{bmatrix} 0 \\ \frac{1}{L} \\ 0 \\ 0 \\ 0 \end{bmatrix}. \quad (10)$$

In order to analysis in the follow section, Eq.(10) is simplified in the matrix form

$$\dot{x} = Ax + Bu + Fe, \quad (11)$$

$$y = Cx, \quad (12)$$

where $x = [i_{dc}^2 \quad i_d \quad i_q \quad v_{cd} \quad v_{cq}]^T$; $u = [i_{id} \quad i_{iq}]^T$;

$$e = V_s, y = [i_{dc}^2 \quad i_q]^T.$$

$$A = \begin{bmatrix} -\frac{2R_{dc}}{L_{dc}} & -\frac{3V_s}{L_{dc}} & 0 & 0 & 0 \\ 0 & -\frac{R}{L} & \omega_0 & \frac{1}{L} & 0 \\ 0 & -\omega_0 & -\frac{R}{L} & 0 & \frac{1}{L} \\ 0 & -\frac{1}{C_s} & 0 & 0 & \omega_0 \\ 0 & 0 & -\frac{1}{C_s} & -\omega_0 & 0 \end{bmatrix}, B = \begin{bmatrix} 0 & 0 \\ 0 & 0 \\ 0 & 0 \\ \frac{1}{C_s} & 0 \\ 0 & \frac{1}{C_s} \end{bmatrix}, \quad (13)$$

$$F = \begin{bmatrix} 0 \\ -\frac{1}{L} \\ 0 \\ 0 \\ 0 \end{bmatrix}, C = \begin{bmatrix} 1 & 0 & 0 & 0 & 0 \\ 0 & 0 & 1 & 0 & 0 \end{bmatrix},$$

where $i_{dc}^2, i_d, i_q, v_{cd}$ and v_{cq} are defined as the state variables, i_{id} and i_{iq} are the input variables, i_{dc}^2 and i_q are the output variables, $R, L, C_s, R_{dc}, L_{dc}, V_s$ and ω_0 are system parameters and considered as constants.

Decoupled state-feedback controller design

In Section 2, a linear model for the CSI-based STATCOM was derived. In this section, the decoupled state-feedback with assistant PI controller is formulated. In order to eliminate the state error when modeling the system, an assistant PI controller is designed. For a linear system represented by eq. (11) and eq. (12), it is easy to design a state-feedback controller. The controller can be described as the following form:

$$u = -Kx + Ty_{ref} + Me, \quad (14)$$

where $y_{ref} = [(i_{dc}^2)_{ref} \quad i_{qref}]$ is the reference input, K is a 2×5 constant state-feedback gain matrix for state-variables x , T is a 2×2 constant diagonal gain matrix for the reference input, and M is a 2×1 constant gain vector.

According to eqs.(11)~(14), the relationship between the input and output of close loop controller is

$$y = C(SI - A + BK)^{-1} [BTy_{ref} + (BM + F)e]. \quad (15)$$

In order to eliminate the cross coupling between i_{dc} and i_q , it is necessary to choose some of the entries of K to make the matrix $C(SI - A + BK)^{-1}B$ diagonal. The poles of the close-loop system are set on the negative axis in order to obtain a fast, smooth, transient response without

overshoot. According to this principle, the parameter K can be computed using MATLAB.

Under steady state, $\dot{x} = 0$, Eq.(15) can be expressed as

$$y = C(BK - A)^{-1} [BTy_{ref} + (BM + F)e]. \quad (16)$$

In order to let y track the reference value y_{ref} , the following condition must be satisfied:

$$\begin{cases} C(BK - A)^{-1} BT = E, \\ C(BK - A)^{-1} (BM + F)e = 0, \end{cases} \quad (17)$$

where E is a 2×2 identify matrix. According to eq.(17), the entries of T and M can be found. Therefore, the parameters of state-feedback controller are all obtained.

Because of neglecting the power loss in R and switches when we linearize the STATCOM system, it may cause the steady-state error. In order to eliminate the error, a PI controller is proposed. The PI controller can keep the output variables to track the reference input variables. The final controller can be the form of

$$u = -Kx + Ty_{ref} + Me - \begin{bmatrix} K_p & K_i \end{bmatrix} \left(\begin{bmatrix} y \\ \int_0^t y \end{bmatrix} - \begin{bmatrix} y_{ref} \\ \int_0^t y_{ref} \end{bmatrix} \right), \quad (18)$$

where $[K_p \quad K_i]$ is a 2×4 constant matrix.

Assuming elements in the K , T and M are all zeroes, and define a new integral vector $x_I = \int_0^t y dt = \int_0^t Cx dt$, therefore, the controller can be revised as:

$$u = -\begin{bmatrix} K_p C & K_i \end{bmatrix} \begin{bmatrix} x \\ x_I \end{bmatrix} + \begin{bmatrix} K_p & K_i \end{bmatrix} \begin{bmatrix} y_{ref} \\ \int_0^t y_{ref} \end{bmatrix}. \quad (19)$$

The new system can be expressed by

$$\begin{bmatrix} \dot{x} \\ \dot{x}_I \end{bmatrix} = \begin{bmatrix} A & 0 \\ C & 0 \end{bmatrix} \begin{bmatrix} x \\ x_I \end{bmatrix} + \begin{bmatrix} B \\ 0 \end{bmatrix} u + \begin{bmatrix} F \\ 0 \end{bmatrix} e. \quad (20)$$

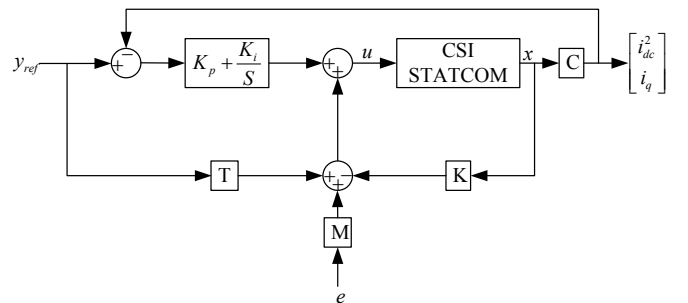

Fig. 2. Block diagram of the STATCOM controller

The entries of $[K_p \quad K_i]$ can be uniquely found based on the specified set of poles of the system and making the

system decoupled. The block diagram of the whole STATCOM controller is shown in Fig 2.

Simulation results

In order to test performance of CSI-based STATCOM described by the linear model, extensive simulation results by PSCAD/EMTDC are provided. All the simulations are based on the 230kV/100MVA power rating system which is shown in Fig. 3.

The system consists of a single machine infinite bus (SMIB) with a STATCOM. The base values for the voltage and power are taken to be 230 kV and 100 MVA, respectively. The voltages at both ends are 1.0 p.u., and $\delta=30^\circ$. The line impedance is $0.01+j0.03$ p.u., which is split equally on the left- and right-hand sides of the connecting point of the STATCOM. In Fig.3, the line resistor and inductance of each phase is $R=0.15\Omega$ and $L=1.2mH$. The capacitance of the filter capacitors is $C_s=90\mu F$. The dc inductor is sized at 50mH to ensure a dc current ripple of less than 5%. The dc resistor is neglected. The switching frequency is set to 1350Hz, which means 27 times higher than the fundamental frequency. Three types of simulation results are shown in Figs.4-6.

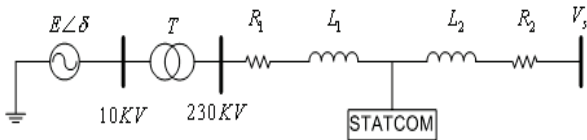

Fig. 3. Schematic diagram of simulation system

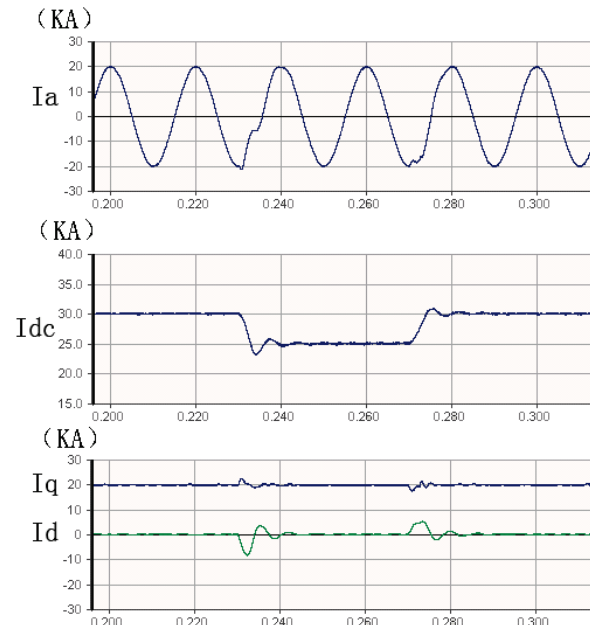

Fig. 4. Step response of I_{dc} : Waveforms of inject current I_a ; dc current I_{dc} ; reference and real value I_d, I_q

Fig.4 shows how the dc current can be regulated to its reference values. At first, I_{dc} is maintained at 30 kA, the peak value of STATCOM output current I_a is about 20 kA, the reference values of I_q and I_d are 20kA, 0kA, respectively. At $t=230ms$, the dc current reference are

changed into 25 kA. As shown in Fig. 4, I_{dc} follows the change in the reference and reaches the new set-point within a half cycle, with very small disturbance on the reactive power exchange, which is represented by I_q . The total harmonic distortion (THD) of the injected current is always less than 3%. At $t=270ms$, the dc current reference is recovered to 30 kA. Similarly, I_{dc} follows the change in the reference and reaches the new set-point within half a cycle.

Fig. 5 shows how the responsibility of applying a step changes in the q-axis current reference values. At first, I_q is maintained at 10 kA, and the peak value of STATCOM output current I_a is about 10 kA. At $t=160ms$, the q-axis current reference is changed into 20kA. As shown in Fig.5, I_q tracks the change in the reference and reaches the new set-point within 0.2 cycle, with very small influence on the dc quantity. The proposed control strategy yields a fast dynamic response in the ac current waveform.

Fig. 6 shows how the dc current and the q-axis current can be regulated to its reference values at the same time. At first, I_{dc} is maintained at 20 kA, I_q is 10 kA, and the peak value of I_a is 10kA. At $t=450ms$, the dc current reference is changed into 30 kA, meanwhile the q-axis current reference is changed into 20kA. As shown in Fig.6, I_{dc} and I_q follow the change in the reference and reach the new set-point within half a cycle. The total harmonic distortion (THD) of the injected current is very small. The reactive power can increase geminately within half a cycle.

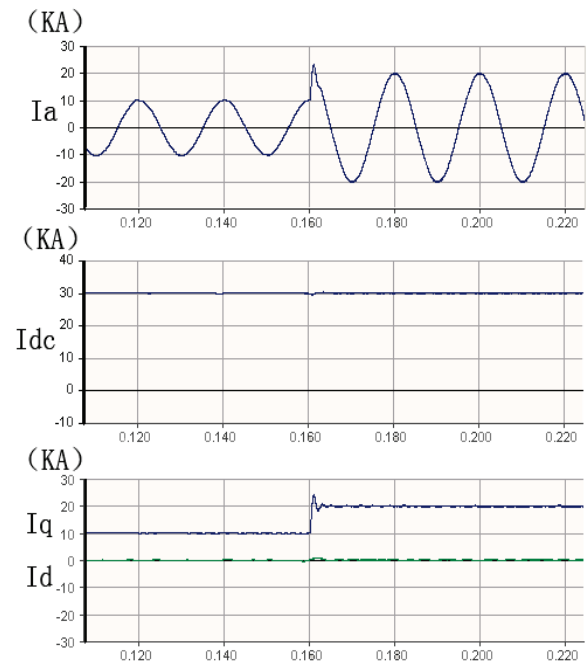

Fig. 5 Step response of I_q : Waveforms of inject current I_a ; dc current I_{dc} ; reference and real value I_d, I_q

It can be concluded from Fig.4-6 that there exists no cross coupling between I_{dc} and I_q , thus they can regulated separately introducing minimal disturbance to each other. The poles of the system are on the negative real axis, which yields a fast, smooth, non-oscillatory transient response in the I_{dc} and I_q . What's more I_{dc} can be stepped down to minimize the loss if the reactive

power compensation is not necessary. On the contrary, I_{dc} and I_q can be stepped up to excite the STATCOM.

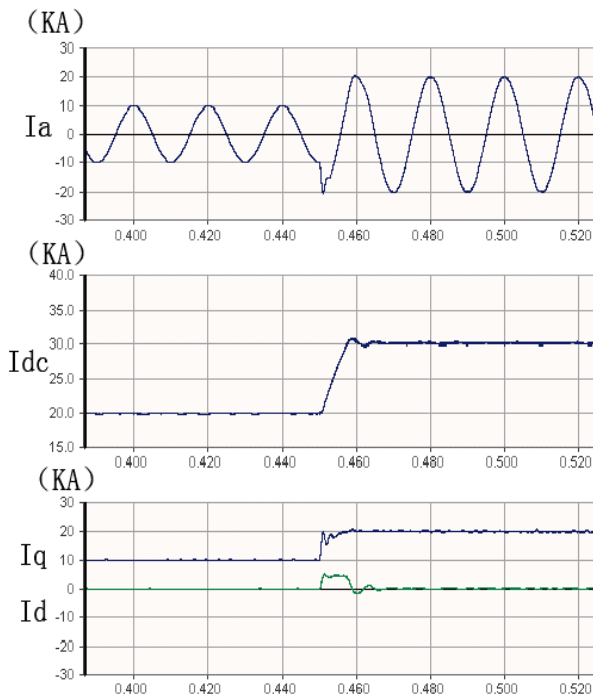

Fig. 6 Step response of I_{dc} and I_q : Waveforms of inject current I_a ; dc current I_{dc} ; reference and real value I_d , I_q

Conclusion

In this paper, a CSC-based STATCOM is proposed. A linear model for the STATCOM is derived from the original nonlinear model by applying the power balance equation and a nonlinear input transformation. The new linear model is independent of the operating point. The decoupled state-feedback control with a reduced-order state estimator is formulated and applied to the CSC-based STATCOM.

The performances of the STATCOM at steady-state and in response to step changes in the reference values of the system voltage and the dc-side current are evaluated using the simulation results from PSCAD/EMTDC package.

The simulation results indicate that the CSC-based STATCOM can fulfill all the objectives of a STATCOM. The CSC-based STATCOM has the potential of becoming

a new FACTS device because of its fast response and low harmonic distortion in the injected current while being operated at a very low switching frequency. This will pave the way for other CSC-based FACTS devices.

Similarly, in the future work, the control strategy based on state-feedback assisted with PI controller can be applied to the VSI-STATCOM topology, which also can improve the performance of VSI-STATCOM.

References

1. **IEEE Recommended Practice for Monitoring Electric Power Quality.** – IEEE Std-1159. – 1995.
2. **Larsen E. V., Miller N., Nilsson S.** Benefits of GTO-Based Compensation Systems for Electric Utility Applications // *IEEE Trans on Power Delivery.* – 1992. –Vol. 7, No. 4. – P. 2056–2064.
3. **Liu Wen-hua, Jiang Qi-rong, Liang Xu.** Field test and operation of ± 20 Mvar STATCOM // *Automation of Electric Power Systems.* – 2000. –Vol. 24, No. 23. – P. 43–46.
4. **Schauder, Gernhardt M., Stacey E.** Operation of ± 100 MVAR TVA STATCOM // *IEEE Trans. Power Delivery.* – 1997. – Vol. 12, No. 4. – P. 1805–1811.
5. **Mori S., Matsuno K., Hasegawa T.** Development of a large static Var generator using self-commutated inverters for improving power system stability // *IEEE Trans on Power Systems.* – 1993. – Vol. 8, No. 1. – P. 371–377.
6. **Andrzej M. Trzynadlowski, Niculina Patriciu, Frede Blaabjerg, John K. Pedersen.** A hybrid, current-source/voltage-source power inverter circuit // *IEEE Trans on Power Electronics.* – 2001. – Vol. 16, No. 6. – P. 866–871.
7. **Ichikawa F., Suzuki K., Nakajima T.** Development of self-commutated SVC for power system // *Proc. IEEE Power Conversion Conf. Yokohama'93.* – 1993. – P. 609–614.
8. **Zhou L., Khan M. M., Ji F., Yao G., Xie D., Chen C. and Shu J.** On using linear periodically resetting filter in current control loop for active power filter // *Journal of Circuits, Systems, and Computers.* – 2006. – Vol. 15, No. 4. – P. 615–639.
9. **Dong Shen, Lehn P.W.** Modeling, analysis, and control of a current source inverter-based STATCOM // *IEEE Trans on Power Delivery.* – 2002. – Vol. 17, No. 1. – P. 248– 253.
10. **Shauder C., Mehta H.** Vector analysis and control of advanced static VAR compensators // *IEE Proc.-C.* – 1993. – Vol. 140, No. 2. – P. 299– 306.
11. **Taleb R., Meroufel A.** Control of asymmetrical Multilevel Inverter Using Artificial Neural Network // *Electronics and Electrical Engineering.* – Kaunas: Technologija, 2009. – No. 8. – P. 93–98.

Received 10 29 2009

Gang Yao, LiXue Tao, LiDan Zhou, Chen Chen. State-feedback Control of a Current Source Inverter-based STATCOM // *Electronics and Electrical Engineering.* – Kaunas: Technologija, 2010. – No. 3(99). – P. 17–22.

The static synchronous compensator (STATCOM) is well known as a reactive power compensator with the best performance in the power system recently, which is used in power systems to regulate the line voltage, enhance the power transmission capacity and extend the transient stability margin. STATCOM is conventionally realized by a voltage-source converter; however, being a current injection device, its performance can be improved when realized by a current-source converter (CSC) that can generate a controllable current directly at its output terminals. A STATCOM based on the current-source converter topology is proposed. The nonlinear model of the current-source converter, which is the source of the difficulties in the controller design, has been modified to a linear model through a novel modeling technique. The proposed modeling technique is not based on the linearization of a set of nonlinear equations around an operating point. Instead, the power balance equation and a nonlinear input transformation are used to derive a linear model independent of the operating point. This model acts as the basis for the design of a decoupled state-feedback controller. The proposed STATCOM has been simulated using the PSCAD/EMTDC package. The simulation results show that a CSC-based STATCOM can result in excellent current and voltage waveforms as well as very short response time while operating at a low switching frequency. This makes the proposed scheme suitable for high power applications. Ill. 6, bibl. 11 (in English; summaries in English, Russian and Lithuanian).

Ган Яо, ЛиХсу Тао, ЛиДан Жоу, Чэн Чэн. Управление источника тока STATCOM на основе инвертора с обратной связью // Электроника и электротехника. – Каунас: Технология, 2010. – № 3(99). – С. 17–22.

Статические синхронные компенсаторы (STATCOM) хорошо известны как компенсатора реактивной мощности, которые используются в энергетических системах для регулирования напряжения, повышения мощности линии передачи и повышения переходной границы стабильности. STATCOM обычно осуществляется при помощи преобразователя напряжения. Однако, ее производительность может быть улучшена, используя преобразователь тока (CSC), который может генерировать управляемый ток непосредственно на выходных терминалах. Предлагается топология STATCOM на основе конвертора тока. Нелинейная модель преобразователя тока, которая и является источником. Проблем при проектировании контроллера, была модифицирована в линейную модель с помощью нового метода моделирования. Предложенная методика моделирования основывается не на линеаризации совокупность нелинейных уравнений. Вместо этого уравнения энергетического баланса и нелинейного преобразования входных сигналов используются для получения линейной модели независимой рабочей точки. Эта модель действует в качестве основы для разработки регулятора с обратной связью. Предложен STATCOM моделирован, используя PSCAD/EMTDC программу. Результаты моделирования показывают, что STATCOM на основе CSC может создать качественные сигналы тока и напряжения, а также обеспечить очень короткое время реакции при работе на низкой частоте переключения. Ил. 6, библи. 11 (на английском языке; рефераты на английском, русском и литовском яз.).

Gang Yao, LiXue Tao, LiDan Zhou, Chen Chen. Srovės keitiklio pagrindu sudaryto STATCOM valdymas grįžtamuoju ryšiu ryšį // Elektronika ir elektrotechnika. – Kaunas: Technologija, 2010. – Nr. 3(99). – P. 17–22.

Statiniai sinchroniniai kompensatoriai (STATCOM) gerai žinomi kaip labai efektyvūs reaktyviosios galios kompensatoriai. Jie naudojami elektros tiekimo linijų įtampai reguliuoti, perduodamai galiai ir pereinamojo stabilumo ribai padidinti. STATCOM paprastai konstruojamas naudojant įtampos keitiklį, tačiau jo našumą galima padidinti naudojant srovės keitiklį (CSC), išėjimo jungtyse galintį generuoti reguliuojamą srovę. Pasiūlyta srovės keitiklio pagrindu sudaryto STATCOM topologija. Netiesinis srovės keitiklio modelis, sukeliantis daugiausia problemų projektuojant valdiklius, nauju modeliavimo metodu, pakeistas į tiesinį modelį. Siūlomas modeliavimo metodas remiasi tuo, kad galios balanso lygtis ir netiesinė įėjimo signalo transformacija naudojama sukurti tiesiniam modeliui, kuriems neturėtų įtakos darbinio taško parametrai. Šio modelio pagrindu projektuojamas grįžtamuojo ryšio valdiklis. Pasiūlytasis STATCOM sumodeliuotas PSCAD/EMTDC aplinkoje. Modeliavimo rezultatai parodė, kad CSC pagrindu sukurtas STATCOM gali tiekti kokybiškus srovės ir įtampos signalus ir pasižymi labai trumpa reakcijos trukme, kai perjungimo dažnis yra nedidelis. Il. 6, bibli. 11 (anglų kalba; santraukos anglų, rusų ir lietuvių k.).

DOI: 10.5755/j02.eie.9897