

Advanced Forward-Looking Sonar and Imagery Data Processing

J. Berdnikova, V. Kozevnikov, J. Zamarajev, A. Raja

Department of Radio and Communication Engineering, Tallinn University of Technology,
Ehitajate tee 5, 19086 Tallinn, Estonia, phone: +3726202350, e-mail: juliad@lr.ttu.ee

Introduction

Intensifying maritime traffic and growing safety demands require that the technical level of electronic equipment for the vessels be upgraded. Obviously, the coastal and harbor areas are attracting more attention. Furthermore, the protection of vessels from numerous threats, underwater object avoidance and navigation support in dangerous waters are main maritime safety problems. Advanced technology allows us to implement real time multifunctional solutions in sonar technology.

Active sonars could be divided by their system construction type: down-looking, sidescan and forward-looking solutions. Each type is based on appropriate system design and signal reception principles. The high end forward-looking sonars (FLS) are generally used for navigation safety purposes on large ships and vessels. The less expensive digital mobile FLS solution can cover the whole consumer range, including small boats and yachts.

The development of the digital forward-looking sonar could be divided into the following stages:

- phased-array pattern and beamforming problems
- sounding signals and optimum reception algorithms
- processing of the received data, extracting information useful for navigation and safety.

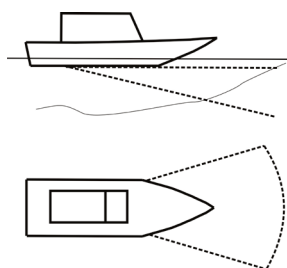

Fig. 1. Forward-looking sonar

This paper analyzes advanced digital FLS system development with a focus on the simplified beamforming model, optimum reception algorithms and received data structure and processing.

Sensor array and digital beamforming

In general, a phased array antenna consists of radiation elements and could be presented as an array of separate narrow beam transducers. High quality transducers significantly decrease the economic efficiency of the system. Regarding the efficiency, wide beam transducers or multichannel receiving modules with similar characteristics could be used as an alternative to narrow ones. Consequently, we have to solve the beamforming task with appropriate processing.

The beamforming theory proposes different digital techniques [1] for specific applications. As an example, we have modeled the linear equivalent distance sensor array with K elements [1, 2].

In practice, the array output could be formed as follows:

$$A_{\Sigma}(u) = \sum_{k=0}^{K-1} h(k) \cdot A_k \cdot e^{-j \frac{2\pi k u}{K}}, \quad (1)$$

where

$$u = \frac{\sin \beta_{\gamma}}{\sin \beta} = K \cdot d \cdot \frac{\sin \beta_{\gamma}}{\lambda}, \quad (2)$$

where β – beam steering angle $\in \{-\pi, \pi\}$; β_{γ} – angle of signal reception $\in \{-\pi, \pi\}$; d – distance between sensors; λ – carrier frequency wavelength; $h(k)$ – weight coefficient of the k -th sensor; A_k – complex amplitude of the k -th sensor [3, 4].

The analysis of the proposed digital beamforming algorithm shows that for each discrete value we should realize K multiply and sum operations. For example, the implementation of the FLS system with the $K=31$ array elements and transducer frequency of $f_0 = 200$ kHz with 4 points per period would require a 16-bit A/D converter working at the frequency $F_a = K \cdot f_0$ for every channel. In

consequence, the beamformer should do about $8 \cdot 10^8$ sum and multiply operations per second and with the 28 Kbytes of memory for intermediate data storage. It is reasonable to apply parallel computing with FPGA (Field-

Programmable Gate Array integrated circuit). Concerning simple beamforming, one of the cost effective solutions in a real 31-element array FLS system could be, for example, XILINX SPARTAN-3 series FPGA. However, advanced digital beamforming methods [4] used would increase the number of summing and multiplication operations significantly.

Signals and reception

Different waveforms are characterized by several performance characteristics. Sounding signal selection is one of the main system design stages. Range resolution, Doppler resolution, sidelobe level and signal-to noise ratio (SNR) of the signals do not only affect system performance, they determine the quality range of the application as well. Regarding the FSL discussed previously, a sounding signal must provide:

- good range resolution
- low peak and mean values for optimal amplifier performance
- smaller possible output power value at the fixed range.

As pulse compression has several performance advantages over simple pulses, amplitude phase manipulated waveforms are used. Signals formed with binary phase codes have the spread spectrum structure, allowing a decrease in the power level of the FLS. The range resolution of the binary phase coded signals calculated by the signal element τ_e length and the angular resolution of the FLS is determined by the antenna beamwidth.

In general, the FLS system with the digital signal processing unit allows generation and appropriate processing of different waveforms.

One of the opportunities would be the Barker code and nested Barker codes, as matched filtering could be used for reception [5]. The code of length 13 has sidelobe level relative to the peak of -22.3 dB and the resolution

$$r = \frac{c \cdot \tau_c}{2}, \quad (3)$$

where τ_c – time period of the signal element; c – speed of sound in water (Fig. 2).

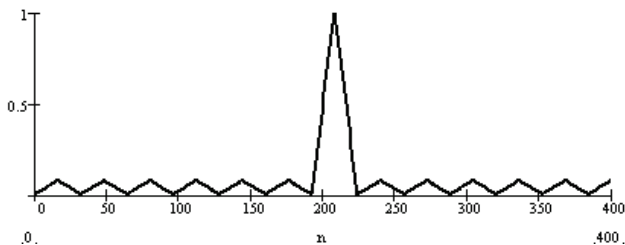

Fig. 2. Phase manipulated waveform (Barker 13) at receiver output

The nested codes (Fig. 3) would have the same sidelobe level and resolution values. Typically, the ratio is required to be at least -30 dB. Because of the fact that sidelobe from a strong target echo can sometimes weaken

or even completely mask the mainlobe of a smaller target echo, additional sidelobe suppression is needed [6, 7, 8].

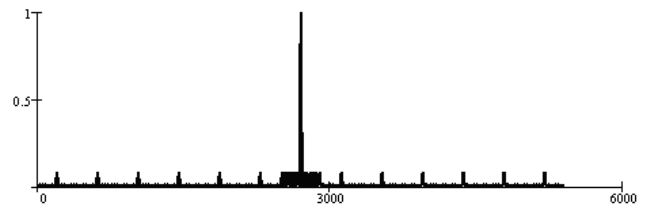

Fig. 3. Phase manipulated waveform (nested Barker 13x13) at receiver output

It is possible to do sidelobe suppression for the original Barker code signals and for the nested Barker code signals as well. Figure 4 illustrates the obtained peak sidelobe -43 dB level of the previously discussed Barker 13 signal with a reasonable SNR loss. Besides, the most important signal generation and received signal processing stages are easily adapted for any code length.

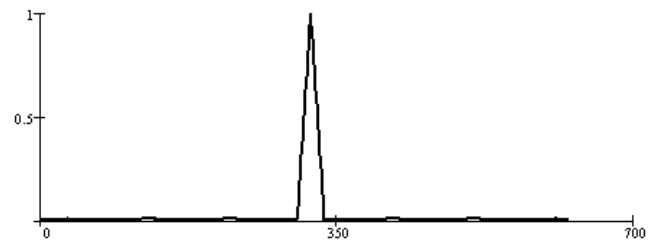

Fig. 4. Phase manipulated waveform (Barker 13x13) with suppressed sidelobes at receiver output

In practice if we use the nested 13x13 Barker with 16 periods of the carrier signal per element and with previously discussed system parameters (31 array elements, 200 kHz, 4 points per period, 16-bit ADC) reception would require about $4 \cdot 10^9$ sum/multiply per second and a memory block of 700 Kbytes.

Obviously processing could be realized by DSP. This could be solved, for example, by two 400 MHz DSP with sufficient memory (e.g., Analog Devices ADSP21469). This calculation considers necessary data transfers between multiprocessor system parts. Furthermore, the output data of the processed FLS system signals will be around 100Mbps.

Forward-looking sonar data and imagery data processing

A typical received and processed signal after an optimal filtering stage is presented in Figure 5.

It illustrates raw data points both with noise and object reflections and effects caused by signal propagation and reflection in water. Unwanted effects of the main FLS system will be:

- time-selective fading, as the used sounding signal length is relatively long
- frequency-selective fading as the result of the reflection from the range-spread targets
- reverberation of the echo signal caused by multiple target reflection [9, 10].

Furthermore, those effects can be regarded as carrier frequency parasitic amplitude modulation. On the one hand, local maximum points correspond to the maximum SNR at the determined interval and characterize the target better than the averaged characteristics. On the other hand, the raw range data amount at optimal receiver output allows us to do both imagery data processing and apply the additional data processing. Besides, the quantity of received data significantly exceeds our display possibilities.

The discussed forward-looking sonar at the 100 m range distance produces about $27 \cdot 10^3$ points in one channel. Typical screen image is about 10^3 points. So the redundant information in the raw data will be effectively used for data extraction necessary for navigation, image enhancement techniques and for the decrease of an output data stream. Figures 5–7 show different implemented FLS raw data processing methods.

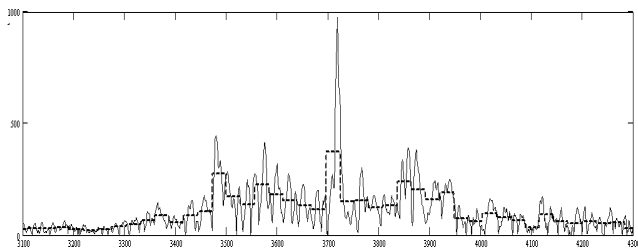

Fig. 5. Raw data processed with mean algorithm

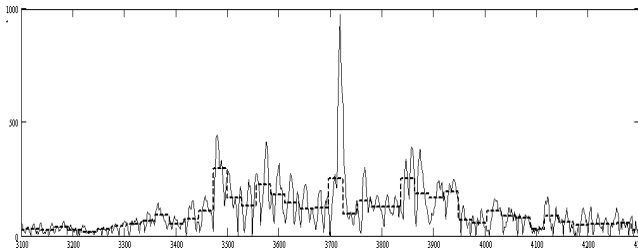

Fig. 6. Raw data processed with median algorithm

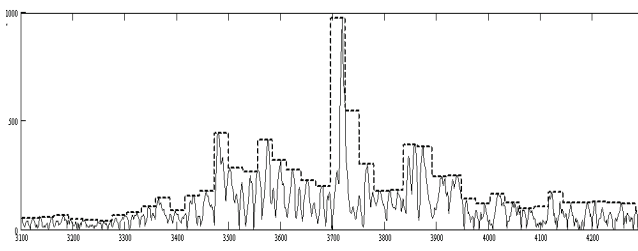

Fig. 7. Raw data processed with maximum (peak detector) algorithm

Modeling results show that the peak detecting method follows the raw data object reflections in the most appropriate way and it also provides a parasitic effect suppression [11]. This type of the raw data post-processing requires no large computing power resources (we add only 1 operation per output data point) and could be compared with averaging. Regarding the median algorithm, the proposed FLS structure should be added as an additional DSP resource. The final images of the FLS system with a median and peak detector are shown in Figures 8-9.

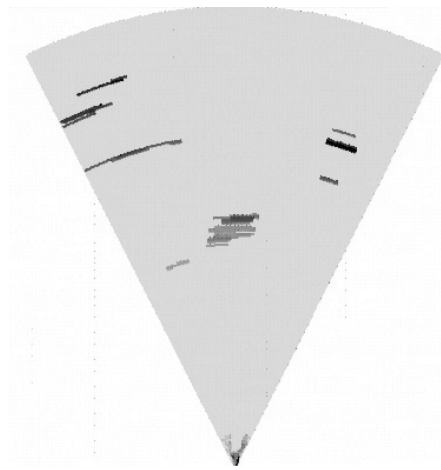

Fig. 8. Experimental FLS system image with mean algorithm

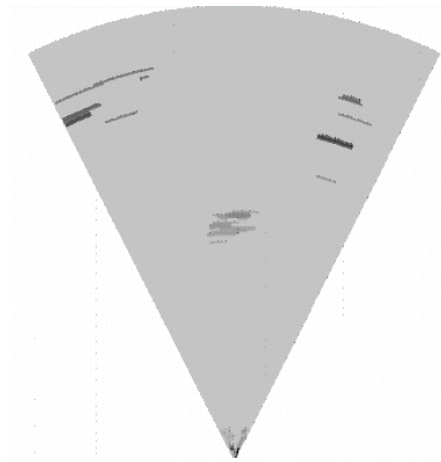

Fig. 9. Experimental FLS system image with peak detector algorithm

Structure of forward-looking sonar module

All the necessary processing stages of the data reception completed, the FLS module can be implemented. The digital signal processing algorithm has the following stages:

1. sounding signal generation;
2. data reception from N sensors;
3. N-channel beamforming;
4. optimal filtering in N channels;
5. data post processing in N channels.

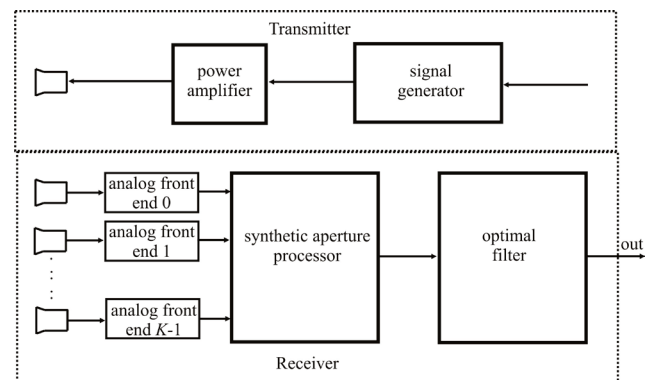

Fig. 10. The structure of the FLS module

Moreover, FLS module structure includes the necessary digital part and analog front ends with separate array elements (Fig. 10).

The flexibility of the proposed solution allows changing the sounding signal structure, beamforming and optimal processing according to particular application needs. Besides, the module output data could be post processed in real time by the PC, creating the 2D FLS images for navigation.

Conclusions

Digital sonar systems have become an essential component of hydrography and vessel navigation. Due to digital signal processing it is possible to design and implement multifunctional cost effective FLS solutions. The discussed beamforming could be a subject for future research. Moreover, spread spectrum nested sounding signals with suppressed sidelobes provide longer working range and increase significantly the range resolution. Reception algorithms could be dynamically changed and application adopted. The analyses of the modeled system computation resource needs allowed implementing a cost effective real system prototype. The goal of the research was to study the raw data structure and possible post-processing methods. However, additional research of the output data processing is required. Future work will extend the processing capabilities of imagery data and will continue to develop a flexible system for navigation specific needs.

References

1. **Bhattacharyya A. K.** Phased Array Antennas. –Wiley–Interscience, 2006. – 496 p.
2. **Arro I., Derkats J., Duhnik A.** Interaction of the PSK signal with a phase array // Electronics and electrical engineering. – Kaunas: Technologija, 2002. – No. 3. – P. 50–52.
3. **Ruuben T., Derkats J.** Some Methods of Signal Processing and Beamforming in Hydrographic Applications // Electronics and electrical engineering. – Kaunas: Technologija, 2006. – No. 6. – P. 27–32.
4. **Ruuben T.** Wideband Digital Beamforming in Sonar Systems. Doctoral thesis. – Tallinn University of Technology Press, 2009. – 140 p.
5. **Richards M. A.** Fundamentals of radar signal processing. McGraw–Hill, New York, 2005. – 513 p.
6. **Fam A. T., Sarkar I.** Multiplicative Mismatched Filter for Optimum Sidelobe Suppression in Barker Codes // Proceedings of SPIE, the International Society for Optical Engineering. – International Society for Optical Engineering, 2006.
7. **Sarkar I., Fam A. T.** Factored Multiplicative Mismatched Filters for Compound Barker Codes // Radar Conference. – IEEE, 2007.
8. **Sato R., Shinriki M.** Time Sidelobe Reduction Technique for Binary Phase Coded Pulse Compression // IEICE Transactions on Communications. – IEEE, 2000.
9. **Van Trees H. L.** Detection, estimation, and modulation theory: Radar–sonar signal processing and gaussian signals in noise. – John Wiley & Sons, Inc., 2001. – 626 p.
10. **Waite A. D.** Sonar for practising Engineers. – John Wiley & Sons Ltd, 2002. –298p
11. **Blondel F., Murton B. J.** Handbook of seafloor sonar imagery. – John Wiley & Sons Ltd, 1997. – 314 p.

Received 2010 02 16

J. Berdnikova, V. Kozevnikov, J. Zamarajev, A. Raja. Advanced Forward-Looking Sonar and Imagery Data Processing // Electronics and Electrical Engineering. – Kaunas: Technologija, 20XX. – No. 4(100). – P. 55–58.

This paper focuses on a forward-looking sonar prototype, which is the main unit in a complex data acquisition system. The principles and diagrams of the sonar and the corresponding processing algorithms will be described. The goal is to increase forward-looking sonar resolution both by complex amplitude-phase manipulated signals and the sonar imagery data processing. Different real-time processing methods are discussed and modeled. Ill. 10, bibl. 11 (in English; abstracts in English, Russian and Lithuanian).

Ю. Бердникова, В. Кожевников, Ю. Замараев, А. Рая. Современный сонар переднего обзора и обработка видеоизображения // Электроника и электротехника. – Каунас: Технология, 2010. – № 4(100). – С. 55–58.

В представленной статье рассматриваются проблемы создания вперёдсмотрящего сонара, являющегося основным модулем сложной системы сбора данных. Принципы работы сонара рассматриваются в контексте соответствующих алгоритмов обработки. Целью является увеличение разрешения вперёдсмотрящего сонара не только благодаря использованию сложных амплитудно-фазоманипулированных сигналов, но также благодаря постобработке визуальных данных сонара. Представлены результаты моделирования различных методов постобработки. Ил. 10, библи. 11 (на английском языке; рефераты на английском, русском и литовском яз.).

J. Berdnikova, V. Kozevnikov, J. Zamarajev, A. Raja. Priešakinių hidrolokatorių ateities perspektyvos ir vaizdų apdorojimas // Elektronika ir elektrotechnika. – Kaunas: Technologija, 20XX. – Nr. 4(100). – P. 55–58.

Apžvelgti priešakinių hidrolokatorių prototipai, kurie taikomi sudėtingų duomenų rinkimo sistemoje, taip pat hidrolokatorių darbo principai ir duomenų apdorojimo algoritmai. Pagrindinis tikslas yra padidinti priešakinių hidrolokatorių skiriamąją gebą, be kita ko, didinant hidrolokatorių vaizdų apdorojimo greitaveiką. Il. 10, bibl. 11 (anglų kalba; santraukos anglų, rusų ir lietuvių k.)

DOI: 10.5755/j02.eie.9876