

## The Current Transformer Parameters Investigation and Simulations

**P. Rafajdus, P. Braciník, V. Hrabovcová**

*Department of Power Electrical Systems, Faculty of Electrical Engineering, University of Žilina,  
Univerzitná 1, 010 21 Žilina, Slovak Republic, e-mail: paval.rafajdus@kves.utc.sk*

### Introduction

The principle of AC current transformers (CT) is based on the magnetic coupling principle. A typical AC CT consists of a toroidal ferromagnetic core, on which a copper wire of  $N$  turns is wound [1]. The CT has the bushing, rod type design. The primary winding consists of a firmly built-in aluminium or copper band, the end of which is finished either with a flag-shaped end terminal or with a terminating rod. The secondary winding consists of turns  $N$ . A typical AC CT arrangement is shown in Fig. 1. The conductor carrying the measured time-varying current  $i_1$  acts as the primary of the current transformer. The toroid can be clamped around the current-carrying conductor. The winding wound on the toroid acts as the secondary of the current transformer  $i_2$ . The burden resistance  $R_b$  is selected depending on the sensitivity that is required. For better performance, current transformer cores are desired to have high permeability, high resistivity, low hysteresis and eddy current losses [2]. The cores are made of a high grade ferromagnetic alloys or magnetically oriented transformer sheets. On the outer side of encapsulated core are wound the secondary windings for output currents of 5 A or 1 A. All active parts of transformer are encasted into epoxy resin (Fig. 2).

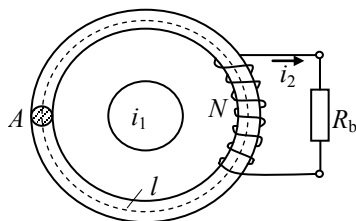

**Fig. 1.** Basic circuit of the current transformer

The current transformers are designed for normal operation, it means, the  $B-H$  curve dependence of iron core is linear. Under normal operation the difference between primary current  $i_1$  and secondary current  $i_2$  is given by their ratio and the magnetizing current can be neglected. The accuracy of CT in this case is very high, approximately 0.5%.

Different situation is during short circuit conditions in power network, when the primary current of CT is several times higher than under normal operation. It causes the non-linear behavior of the current transformer. As it is known, the DC offset in the fault current following into protective core of current transformer can cause steel to saturate and produce a distorted secondary current [3–6]. To know exactly a real primary current during fault operation is very important for the correct action of protection relays and also for the analysis focused on faults' identification and localization.



**Fig. 2.** A real current transformer

In this paper a real CT is investigated under transient condition. It is bar primary bushing type CT TTR61.11 (Fig. 1, 2) with one measuring and one protective winding. The nameplate of CT is following: rated primary current  $I_1 = 600$  A, secondary current  $I_2 = 5$  A, the ratio is 120. The parameters of CT equivalent circuit for protective winding are measured and used in its mathematical model. The  $B-H$  curve is included into mathematical model of transformer and it is expressed by function of magnetizing inductance versus magnetizing current. The simulated current results of sudden short circuit in the network are compared with measured ones.

### Nonlinear mathematical model of CT

The nonlinear mathematical model of CT can be described in accordance with general equivalent circuit of transformer, but the secondary winding is combined with

burden as it can be seen in Fig. 1 and Fig. 3. It consists of lumped parameters of primary winding (resistance of primary winding  $R_1$ , leakage inductance of primary winding  $L_1$ ), secondary winding (resistance  $R_2$ , leakage inductance  $L_2$ ) connected with burden equivalent resistance  $R_b$ . In real conditions,  $R_b$  is resistance of analogue or digital tester. The lumped parameters of secondary winding are referred to the primary side of transformer. The magnetizing branch is represented by a non-linear magnetizing inductance  $L_\mu$ , which is a function of magnetizing current  $I_\mu$ . The eddy current loss is neglected so no resistance has been included in the circuit for this power loss.

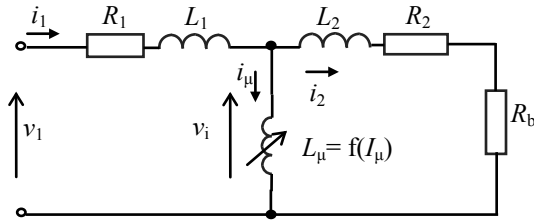

Fig. 3. An equivalent circuit of current transformer

The mathematical model of current transformer consists of following equations

$$i_1(t) = i_2(t) + i_\mu(t). \quad (1)$$

The induced voltage  $v_i$  is given by the equation

$$v_i(t) = N \frac{d\Phi(t)}{dt}, \quad (2)$$

where  $\Phi$  – magnetic flux;  $N$  – the turn ratio of the transformer

$$N \frac{d\Phi(t)}{dt} = i_2(t)R + L \frac{di_2(t)}{dt}, \quad (3)$$

$$R = R_2 + R_b, \quad (4)$$

$$L = L_2 + L_b, \quad (5)$$

where  $L_b$  could be inductance of burden.

Very important task is to establish the relationship between magnetising current and magnetizing inductance, what is non-linear behaviour. It can be obtained from measurement or from analytical calculation. In this paper this non-linear dependence is taken from measurement and included into mathematical and simulation model of the current transformer. Generally, magnetizing inductance can be expressed

$$L_\mu = \frac{N^2 A}{l} \frac{dB}{dH}, \quad (6)$$

where  $A$  is the area of ferromagnetic core of transformer,  $l$  is the length of the magnetic path (see Fig. 1),  $dB/dH$  is the differential permeability or the slope of the  $B$ - $H$  characteristic.

The equation (2) can be rewritten

$$L_\mu \frac{di_\mu}{dt} = v_i, \quad (7)$$

where  $L_\mu = f(I_\mu)$ .

The combination of equations (1), (3) and (7) can be obtained:

$$\frac{di_\mu(t)}{dt} = \frac{1}{L + L_\mu(i_\mu)} \left[ Ri_1 - Ri_\mu(t) + L \frac{di_1(t)}{dt} \right]. \quad (8)$$

If the secondary current is known from the measurement, a real primary current can be calculated from equation (1). This mathematical model is simulated under Matlab/Simulink program. A real CT is simulated with parameters obtained from measurements.

### Measurement of CT equivalent circuit parameters

This measurement is similar as for classical transformers. The arrangement of measurement is shown in Fig. 4.

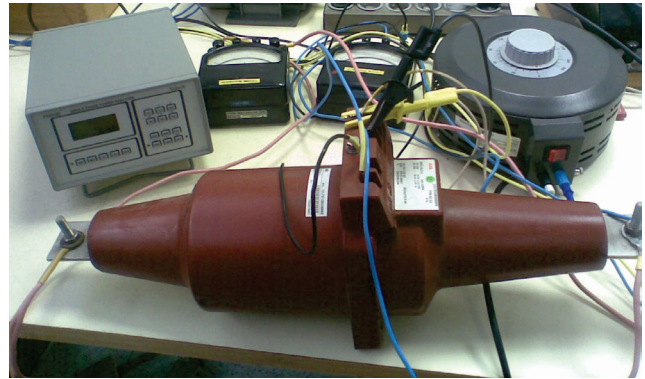

Fig. 4. The parameters measurement equipment

The resistances of primary and secondary parts have been measured by Ohm's method. The primary resistance  $R_1 = 17.86 \mu\Omega$  and secondary resistance is  $R_2 = 0.305 \Omega$ .

Also the transformer ratio has been measured and it is 120.

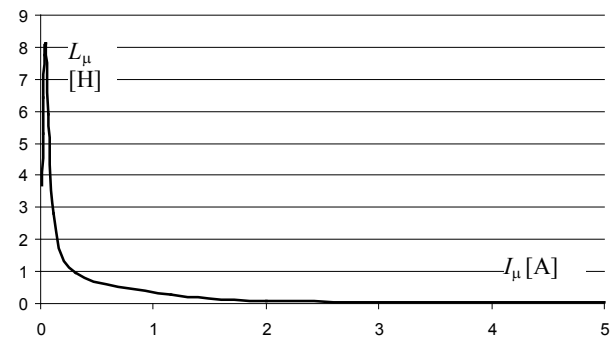

Fig. 5. Dependence of magnetizing inductance versus magnetizing current

Very important parameter is magnetizing inductance. As it has been mentioned above, it is not constant value, but it depends on magnetizing current. This parameter has been measured from no-load measurement and the dependence of  $L_\mu = f(I_\mu)$  is shown in the Fig. 5.

This dependence  $L_{\mu} = f(I_{\mu})$  is used in the nonlinear mathematical model of CT.

The leakage inductances of primary and secondary windings have been measured from short-circuit measurement as a total inductance  $L = 0.008$  H.

### Simulation results

The simulation model has been created under Simulink program for transients (see Fig. 6). The transients were supposed as a sudden short circuit in network for line distance approximately 10 km, what has been chosen on the base of a real sudden short circuit in the network. In the model, the nonlinear dependence of magnetizing inductance versus magnetizing current has been taken into account.

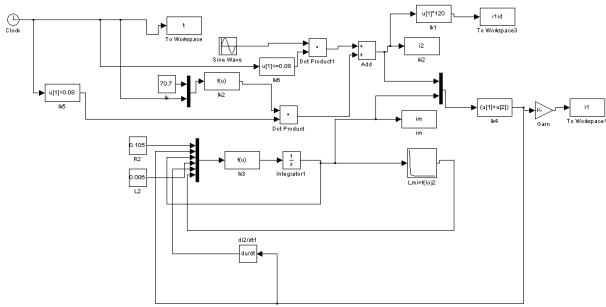

Fig. 6. Transient simulation model under Simulink

As it has been mentioned above, the transient operation is simulated for sudden short circuit in the line distance 10 km in network of 22 kV. The short circuit secondary current  $i_{sc}$  has been calculated from following equation:

$$i_{sc} = \sqrt{2} I_{sc} \left( e^{-\frac{t}{\tau}} - \cos \omega t \right), \quad (9)$$

where  $I_{sc}$  – steady state short circuit secondary current ten times higher than its rated current;  $\tau$  – time constant given by parameters of network. Network's resistance  $R_n = 0.43 \Omega \cdot \text{km}^{-1}$  and inductance  $L_n = 1.2 \text{ mH} \cdot \text{km}^{-1}$  were used in this simulations. The operation of protection relays was neglected in presented simulation.

The simulated secondary current is in the Fig. 7. From time 0 to 0.08 s there is normal rated operation, the secondary rms current is 5 A. At the time 0.08 s, the sudden short circuit is occurred.

The magnetizing current waveform is shown in the Fig. 8. As it is clear form this Fig. 8, the magnetizing current is not sinusoidal during transient and there can be seen dependence of nonlinear part of  $B-H$  curve expressed by means of magnetizing inductance.

In the Fig. 10 there is comparison of primary currents for linear and nonlinear case. The linear case means, that the primary current is calculated only by means of transformer ratio. The error is approximately 0.4 %.

In the Fig.11 is shown the logarithmical dependence of errors for linear and nonlinear cases versus current ratio  $I_{sc} / I_N$ . As it can be seen the errors are low up to ratio 100, what is under 2%. For higher short circuit currents, the

nonlinear transformer model is more different and it is recommended to use it for more accuracy simulation.

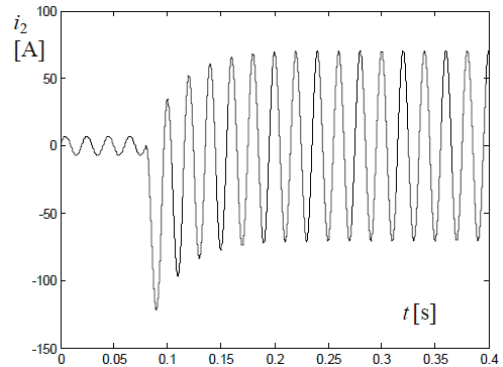

Fig. 7. Transient simulated waveform of secondary current

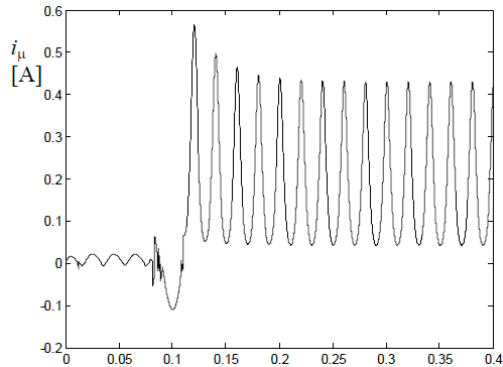

Fig. 8. Transient simulated waveform of magnetizing current

In the Fig. 9, there can be seen simulated primary current.

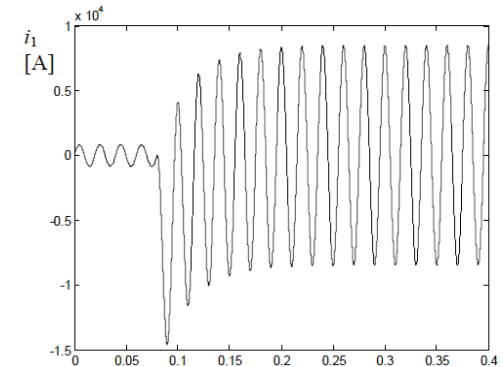

Fig. 9. Transient simulated waveform of primary current

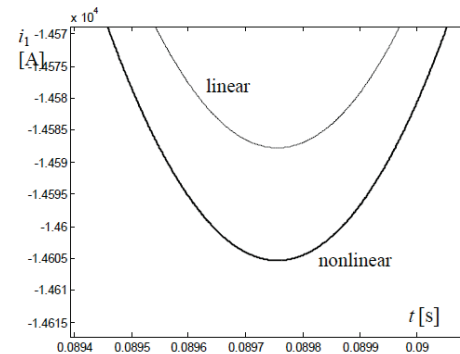
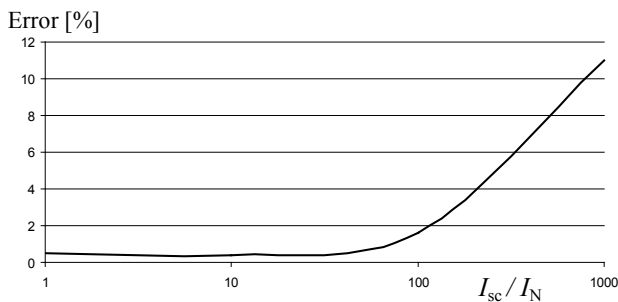

Fig. 10. Comparison of linear and nonlinear mathematical model for transient primary current



**Fig. 11.** Percentage error between linear and nonlinear cases for different current ratio

## Experimental results

The obtained simulated waveforms have been verified by measurement.

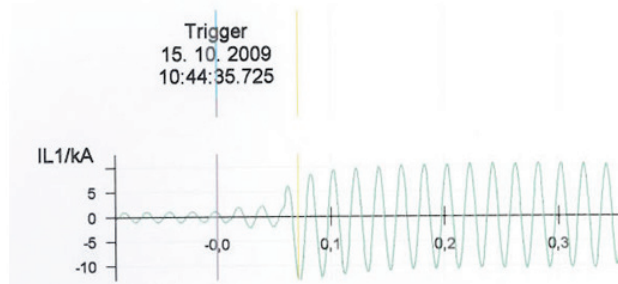

**Fig. 12.** Transient measured waveform of primary current

They were compared with current waveform recorded by protection relay of 22 kV power line (Fig. 12) during the fault caused by snow calamity. As it can be seen from Fig. 9 and Fig. 12, the shape of both waveforms is very similar and difference is very small. These results confirm that created mathematical model represents very closely the behavior of real current transformer. Therefore it could be used in bigger model of 22 kV power network, which was created to analyze new methods for faults' identification and localization.

## Conclusion

In this paper a real current transformer was analyzed by simulation and verified by measurement. The mathematical nonlinear model was defined, created and described. The

simulations have been carried out for steady state and also for transients during sudden short circuit operation. The results were compared with linear model. Created current transformer model will be used in bigger simulation model of medium voltage network. The simulation results are compared also with measured ones and they are in good coincidence. It will help by the development of new method for fault identification and localization.

## Acknowledgment

This work was supported by the Slovak Research and Development Agency under the contract No. APVV-0560-07. The authors wish to thank for the support to the R&D operational program Centre of excellence of power electronics systems and materials for their components. The project is funded by European Community, ERDF – European regional development fund.

## References

1. Lin C. E., Cheng C.L., Huang C. L., Yeh J. C. Investigation of magnetizing inrush current in transformers // IEEE Transaction Power Delivery, 1993. – No. 1(8). – P. 246–253.
2. Tumay M., Simpson R. R. S., El-Khatroushi H. Dynamic model of a current transformer // International Journal of Electrical Engineering Education. – No. 3(37). – P. 268–276.
3. Miedzinski B., Dzierzanowski W., Habrych M., Okraszewski Z. The Influence of Magnetic Shielding on Selectivity of a Hall Sensor based Protection // Electronics and Electrical Engineering. – Kaunas: Technologija, 2009. – No. 3(91). – P. 89–92.
4. Rafajdus P., Bracinič P., Hrabovcová V. Investigation of Current Transformer performance under steady state and transient conditions // International Conference Low Voltage Electrical Machines (LVEM'2009). – Brno, Czech Republic, 2009. – P. 43–46.
5. Rafajdus P., Bracinič P., Hrabovcová V. Mathematical model of current transformer // International Symposium on Electrical Machines (ISEM'2009). – Prague, Czech Republic, 2009. – P. 229–234.
6. Czapp S. Elimination of the Negative Effect of Earth Fault Current Higher Frequency on Tripping of Residual Current Devices // Electronics and Electrical Engineering. – Kaunas: Technologija, 2009. – No. 3(91). – P. 85–88.

Received 2010 02 12

P. Rafajdus, P. Bracinič, V. Hrabovcová. The Current Transformer Parameters Investigation and Simulations // Electronics and Electrical Engineering. – Kaunas: Technologija, 2010. – № 4(100). – P. 29–32.

This paper deals with current transformer (CT) analysis and simulations of transients. The parameters of CT equivalent circuit for protective winding are measured and used in its mathematical model. The  $B-H$  curve is included into mathematical model of transformer and it is expressed by function of magnetizing inductance versus magnetizing current. The simulated current results of sudden short circuit in the network are compared with measured ones. Ill. 12, bibl. 6 (in English; abstracts in English, Russian and Lithuanian).

П. Рафайдус, П. Брацинич, В. Грабовцова. Анализ и синтез параметров токового трансформатора // Электроника и электротехника. – Каунас: Технология, 2010. – № 4(100). – С. 29–32.

Статья занимается анализом и синтезом переходных состояний токового трансформатора. Параметры токового трансформатора измерены и использованы в математической модели. Кривая намагничивания  $B-H$  является составляющей математической модели трансформатора и характеризуется функцией магнетизирующей индуктивности и тока намагничивания. Результаты симуляции токов во время внезапного короткого замыкания сравниваются с измеренными. Ил. 12, библи. 6 (на английском языке; рефераты на английском, русском и литовском яз.).

P. Rafajdus, P. Bracinič, V. Hrabovcová. Srovės transformatoriaus parametų tyrimas ir modeliavimas // Elektronika ir elektrotechnika. – Kaunas: Technologija, 2010. – Nr. 4(100). – P. 29–32.

Ištirti srovės transformatoriaus vykstantys pereinamieji procesai. Srovės transformatoriaus parametrai išmatuoti ir pritaikyti matematinio modeliavimo.  $B-H$  kreivė pateikiama kaip transformatoriaus matematinio modelio sudedamoji dalis, kuri priklauso nuo magnetinės indukcijos ir įmagnetinimo srovės. Pateikti srovės modeliavimo rezultatai palyginti su trumpojo jungimo atveju išmatuotais rezultatais. Il. 12, bibl. 6 (anglų kalba; santraukos anglų, rusų ir lietuvių k.).

DOI: 10.5755/j02.eie.9870