

Two-mass Mariable Speed Drive

S. Juraitis, R. Rinkevičienė

Department of Automation, Vilnius Gediminas Technical University,

Naugarduko str. 41, 03227 Vilnius, Lithuania, phone: +370 699 64173, e-mail: sjura3000@yahoo.com

A. Kilikevičius

Department of Machine Engineering, Vilnius Gediminas Technical University,

J. Basanavičiaus str. 28, 03224 Vilnius, Lithuania

Introduction

Electromechanical system as object of investigation comprises electrical and mechanical parts. Electromechanical power converter and its control system depend to electrical part as well as all moving masses coupled between them form mechanical part. Electromechanical system includes various mechanical chains, with infinite or finite elasticity and clearance. Systems with infinite stiffness and without clearance compose one-mass system and are quite well analyzed. Systems with capable to deform chains are more complex. They are described by high order nonlinear differential equations, and without essential simplifying of problem they cannot be solved in analytical way. In these cases computer models for problem solving must be developed, using specialized software, and system responses simulated. Some problems of two-mass system were considered in [3, 5–10].

Oscillations in the two-mass electromechanical system raise great problem therefore reduction of that becomes the main task in developing of the system. Different control methods in close loop and open loop systems are applied for this purpose [11, 12].

The paper presents closed loop model of two-mass electromechanical system with speed and current feedback. Vector control method with PI controller is applied. Step response when different load is switching at steady-state speed is considered. Simulation at changing of speed at constant different load is presented.

Model of induction motor

Dynamic performance of an AC machine is complex problem taking into account three phase rotor windings moving with respect to three-phase stator windings. The coupling coefficient changes continuously with the change of rotor position θ_r and machine model is described by differential equations with time varying mutual

inductances. To simplify the problem solution, any three phase induction machine can be represented by an equivalent two phase machine with stator direct and quadrature axes $d^s - q^s$ and rotor direct and quadrature axes $d^r - q^r$ [1, 2].

For revolving induction motor it can be written in terms of variables along quadrature and direct axes as:

$$\begin{cases} u_{ds}^s = \left[\left(\frac{1}{L_s} + \frac{L_m k_1}{L_s L_r} \right) \cdot \psi_{ds}^s - \frac{L_m}{L_s L_r} \cdot \psi_{ds}^r \right] \cdot R_s + \frac{d\psi_{ds}^s}{dt}; \\ u_{qs}^s = \left[\left(\frac{1}{L_s} + \frac{L_m k_1}{L_s L_r} \right) \cdot \psi_{qs}^s - \frac{L_m}{L_s L_r} \cdot \psi_{qs}^r \right] \cdot R_s + \frac{d\psi_{qs}^s}{dt}; \\ u_{ds}^r = \left[\frac{1}{L_r} (\psi_{ds}^r - k_1 \cdot \psi_{ds}^s) \right] \cdot R_r + \frac{d\psi_{ds}^r}{dt} + \omega_r \cdot \psi_{qs}^r; \\ u_{qs}^r = \left[\frac{1}{L_r} (\psi_{qs}^r - k_1 \cdot \psi_{qs}^s) \right] \cdot R_r + \frac{d\psi_{qs}^r}{dt} + \omega_r \cdot \psi_{ds}^r, \end{cases} \quad (1)$$

where ψ_{ds}^s, ψ_{ds}^r – stator and rotor flux linkages aligned with the direct axis; ψ_{qs}^s, ψ_{qs}^r – stator and rotor flux linkages aligned with quadrature axis; R_s – stator phase resistance; R_r – rotor phase resistance, referred to stator; $u_{ds}^s, u_{qs}^s, u_{ds}^r, u_{qs}^r$ – stator and rotor voltages. In the stationary reference frame $u_{ds}^s = U_{1\max} \cos \omega_0 t$, $u_{qs}^s = U_{1\max} \sin \omega_0 t$ where $U_{1\max}$ is amplitude of voltage and $\omega_0 = 2\pi f$ is angular frequency. L_m is magnetizing inductance, $L_s = L_{1s} + L_m$ is stator inductance, L_{1s} is stator leakage inductance; $L_r = L_{1r} + L_m$, L_{1r} is rotor leakage inductance referred to stator and $k_1 = L_m / L_s$.

Torque, delivered by motor, is calculated as:

$$T = \frac{\pi p}{L_s L_r - L_m^2} (\psi_{qs}^s \cdot \psi_{ds}^r - \psi_{qs}^r \cdot \psi_{ds}^s), \quad (2)$$

where p – number of pole pairs.

$$\omega_{sl} = \frac{L_m}{|\psi_r|} \cdot \frac{R_r}{L_r} \cdot i_{qs}^* \quad (7)$$

Vector control of induction drive

The vector control method of the induction motor drive is presented in [4]. The inverter is simplified and shown without the power conversion control circuit. Stator currents and motor shaft speed are used in the vector control system. The speed control loop generates the torque component of current i_{qs}^* ; the flux component of current i_{ds}^* for desired rotor flux $|\psi_r|^*$ is maintained constant for simplicity. If the rotor flux is constant in indirect vector control, which is usually the case, then it is directly proportional to steady state current i_{ds} .

Magnitude of the estimated rotor flux linkage is calculated as

$$|\psi_r| = \frac{L_m \cdot i_{ds}}{1 + \tau_r s}, \quad (3)$$

where τ_r – time constant of the rotor electrical circuit.

The direct component of current is found as

$$i_{ds}^* = \frac{|\psi_r|^*}{L_m}, \quad (4)$$

The quadrature component of stator current is

$$i_{qs}^* = \frac{2}{3} \cdot \frac{2}{p} \cdot \frac{L_r}{L_m} \cdot \frac{T_e^*}{|\psi_r|}, \quad (5)$$

where T_e^* – electromagnetic torque.

The angle between d^s and d^e axes, correspondingly in stationary and synchronous reference frames is calculated as [1]

$$\theta_e = \int (\omega_r + \omega_{sl}) dt, \quad (6)$$

where ω_r – rotor speed, ω_{sl} is slip frequency.

Slip frequency is found from the stator current component i_{qs}^* and other motor parameters

According to the vector control method of the induction motor drive and equations (3, 4, 5, 6 and 7) the computer model of the vector-controlled drive, presented in Fig. 1, is developed.

The Simulink model of vector control induction motor drive consists of models for power supply, PWM inverter, induction motor drive in the stationary reference frame and vector control algorithm.

Results of simulation

The model of electromechanical system with speed and current feedback signals is elaborated. Required speed value is maintained by vector control principle with PI controller. The first mass corresponds to the mass of motor rotor. Model of induction motor is considered in [6, 10] according to stationary reference frame with d, q axis. Computer model is elaborated for a motor, which parameters are presented in Table 1:

Table 1. Parameters of a motor

Parameter	Value
Motor power, kW	1,1
Number of pole pairs	2
Phase voltage, V	230
Power factor	0,81
Rated torque, N·m	7
Rated current, A	3,56
Inertia, kg·m ²	0,00262

The second mass is chosen freely. It is assumed as cylindrical shape body, fastened along mass center (see Fig. 1). Its inertia is calculated in this way

$$J = \frac{m \cdot r^2}{2}, \quad (8)$$

where m – mass of cylinder; r – radius of cylinder.

It is assumed in simulation $J=0.0025 \text{ kg}\cdot\text{m}^2$.

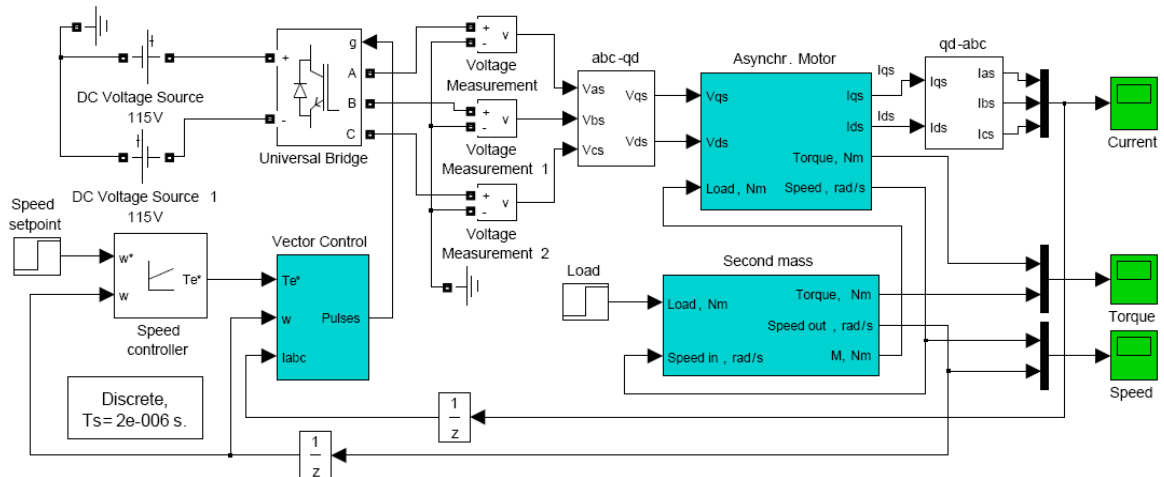

Fig. 1. Model of two-mass electromechanical system with vector control

Two-mass controlled system includes speed and torque reference signals; both those can be changed. Vector control unit controls IGBT inverter, which generates voltage pulses for motor supply. Chosen control method requires enough stiff mass junction, therefore it is selected the elasticity of shaft 100000 N·m/rad. The model of controlled two-mass system is presented in Fig. 1.

Fig. 2 shows simulation results of single-mass system and two-mass system without load. Reference speed is set up to 157 rad/s, i. e. synchronous speed of the motor. Comparison of curves, presented in Fig. 2, indicates single-mass system having shorter settling time than two-mass system. Both curves have no oscillations. Settling time of two-mass system is 0.06 s, the speed steady state value corresponds to reference value. This is advantage of vector control system with PI controller.

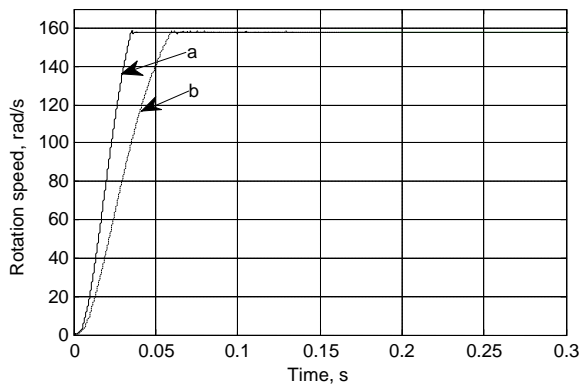

Fig. 2. Comparison of closed loop systems with PI controller at no load: a – single-mass system; b – two-mass system

Simulation results of controlled two-mass system with different load are presented in Fig. 3. Motor is loaded with stepwise load after 0.4 s, after reaching steady-state speed. Figure 3 shows results with rated, lesser than rated and greater than rated load. Rated load is calculated from motor parameters and is equal 7 N·m.

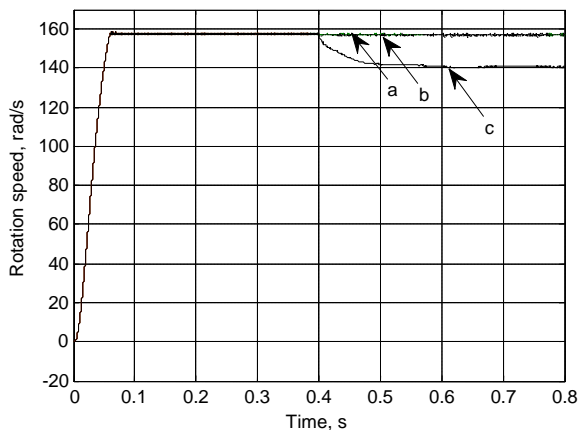

Fig. 3. Comparison of speed values in vector control system at different load torque values: a – load torque is 4 N·m; b – load torque is 7 N·m; c – load torque is 10 N·m

Presented curves indicate, that in the beginning of process, when system operates at no load, motor

accelerates and reaches synchronous angular speed 157 rad/s. After reaching steady-state speed, at $t=0.4$ s the load is applied. At the load smaller than rated or rated, the speed value did not change. At the load greater than rated, the speed reaches new, smaller, than reference value. It can be concluded, that vector control operates without error at load up to the rated. With greater load value angular speed reduces. Applied three different load values did not cause oscillations in the system.

Simulation results of vector controlled system, starting with the load is presented in Fig. 4. After reaching steady-state speed, at $t=0.4$ s, the speed reference is changed from 157 rad/s to 120 rad/s. Comparison of curves of motor starting at no-load indicates shorter settling time at smaller load, but, if the load exceeds rated one, motor does not reach reference speed. At any load, greater than rated, the system speed does not reach the reference. After applied stepwise change of speed reference at 0.4 s, the speed of motor reduces and afterwards reaches the new value, equal to reference. In this way the system is able to keep constant speed value at greater load. It may be concluded that reduced speed reference allows greater load.

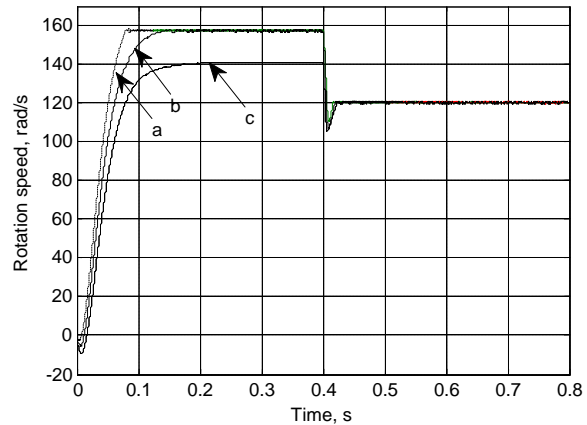

Fig. 4. Comparison of speed values in vector control system at different load torque values: a – load torque is 4 N·m; b – load torque is 7 N·m; c – load torque is 10 N·m

Conclusions

Settling time of speed of two-mass vector controlled system is 0.06 s. Speed response has dead-beat mode, without overshoot.

If the speed reference is equal to synchronous speed and the load torque is applied after speed reaches steady state, the speed of the system remains constant, if the load does not exceed rated value. If the load is greater than rated, the speed reduction is observed.

Settling time of two-mass system depends on load and increases with load.

At the load, greater than rated, speed of the system can be kept constant, if the speed reference is smaller than synchronous speed.

Vector control of two-mass system specifies dead-beat speed response.

References

1. **Bimal K. Bose.** *Modern Power Electronics and AC Drives* // New Jersey: Prentice Hall PTR, 2002. – 738 p.
2. **Rinkevičienė R., Petrovas A.** Model of Vector Controlled Induction Drive // *Solid State Phenomena. Mechatronic systems and materials*, 2009. – Vol. 147-149. – P. 149–154.
3. **Smilgevičius A., Rinkevičienė R.** Simulation of transients in the Mechanical part of Electromechanical system // *Mathematical Modelling and Analysis Proceedings of the 10th International Conference MMA2005&CMAM2.* – Trakai, 2005. – P. 155–162.
4. **Rinkevičienė R., Batkauskas V.** Modeling and Investigation of Vector Controlled Induction Drive // *Electronics and Electrical Engineering.* – Kaunas: Technologija, 2008. – No. 1(81). – P. 53–56.
5. **Smilgevičius A., Rinkevičienė R., Savickienė Z.** Operation of Electric Motor with Elastic Load // *Electronics and Electrical Engineering.* – Kaunas: Technologija, 2006. – No. 6(70). – P. 15–18.
6. **Juraitis S., Rinkevičienė R., Smilgevičius A.** Dynamic properties of two-mass electromechanical system // 6th International Symposium „Topical Problems in the Field of Electrical and Power Engineering“. – Kuressaare, 2009. – P. 18–21.
7. **Feiler M., Westermaier C., Schroder D.** Adaptive speed control of a two-mass system // *Proceedings of IEEE Conference on Control Applications (CCA 2003)*, 2003. – Vol. 1. – P. 1112–1117.
8. **Kara T., Eker I.** Experimental nonlinear identification of a two mass system // *Proceedings of IEEE Conference on Control Applications (CCA 2003)*, 2003. – Vol. 1. – P. 66–71.
9. **Bolognani S., Venturato A., Zigliotto M.** Theoretical and experimental comparison of speed controllers for elastic two-mass-systems // *IEEE 31st Annual Power Electronics Specialists Conference (PESC 00)*, 2000. – Vol. 3. – P. 1087–1092.
10. **Juraitis S., Rinkevičienė R., Kriaučiūnas J.** Modeling of two-mass system with elasticity // *Electrical and Control Technologies.* – Kaunas: Technologija, 2009. – P. 227–230.
11. **Vas P.** *Sensorless vector and direct torque control.* – Oxford University press, 2003. – 729 p.
12. **Novotny D. W., Lipo T. A.** *Vector control and dynamics of AC drives.* – Oxford: Clarendon Press, 2004. – 440 p.

Received 2010 02 22

S. Juraitis, R. Rinkevičienė, A. Kilikevičius. Two-mass Mariable Speed Drive // Electronics and Electrical Engineering. – Kaunas: Technologija, 2010. – No. 4(100). – P. 25–28.

The paper presents the simulation results of the close loop two-mass electromechanical system model with the speed and current feedbacks. Motor speed is controlled by a torque-generated stator current component while maintaining the flux-generated current component steady. The torque-generated current component is corrected to track its set point in the current controller using its own dedicated PI controller. Simulink model of vector controlled two-mass electromechanical system is elaborated. The motor model is developed in stationary reference frame. Simulations results at starting motor at no load and applying different load are analyzed. The change of speed reference of motor, running with different load, is considered. Il. 4, bibl. 12, tabl. 1 (in English; abstracts in English, Russian and Lithuanian).

С. Юрайтис, Р. Ринкявичене, А. Киликвичюс. Регулируемой скорости двухмассовый привод // Электроника и электротехника. – Каунас: Технология, 2010. - № 4(100). – С. 25–28.

Статья представляет модель замкнутой двухмассовой электромеханической системы с обратной связью скорости и тока, представлены результаты моделирования. Скорость двигателя управляется составляющей тока статора, пропорциональной моменту двигателя, а составляющая тока, пропорциональная потоку, поддерживается постоянной. ПИ регулятор тока использован для поддержания и слежения заданной величины этой составляющей тока. Разработана модель векторного управления двухмассовой электромеханической системы. Модель асинхронного двигателя разработана в стационарной системе координат. Исследования проводились путем изменения различных нагрузок при постоянной скорости и изменения скорости при различных нагрузках. Ил. 4, библиограф. 12, табл. 1 (на английском языке; рефераты на английском, русском и литовском яз.).

S. Juraitis, R. Rinkevičienė, A. Kilikevičius. Reguluojamo greičio dvimasė pavara // Elektronika ir elektrotechnika. – Kaunas: Technologija, 2010. – Nr. 4(100). – P. 25–28.

Straipsnyje pristatomi vektorinio valdymo uždarnosios dvimasės elektromechaninės sistemos su greičio ir srovės grįžtamaisiais ryšiais tyrimo duomenys, pateikiami modeliavimo rezultatai. Pavaros greitis reguliuojamas statoriaus srovės dedamąja, proporcinga sukimo momentui, kartu palaikant srauto srovės dedamąją pastovią. Nustatytoji srovės dedamosios vertė, proporcinga momentui, palaikoma naudojant PI valdiklį. Sudarytas vektorinio valdymo dvimasės elektromechaninės sistemos „Simulink“ modelis. Variklio modelis sudarytas nejudamoje koordinatų sistemoje. Atlikti tyrimai esant skirtingo dydžio apkrovai ir nusistovėjusiam greičiui ir keičiant nuostato greitį esant skirtingoms apkrovoms. Il. 4, bibl. 12, lent. 1 (anglų kalba; santraukos anglų, rusų ir lietuvių k.).

DOI: 10.5755/j02.eie.9869