

## Challenges of Close Loop Electronic Medical Systems

**N. Dubauskienė, V. Markevičius**

*Department of Electronics Engineering, Kaunas University of Technology,  
Studentu str. 50-422, LT-51368 Kaunas, Lithuania, e-mails: neringa.dubauskiene@stud.ktu.lt,  
vytautas.markevicius@ktu.lt,*

**A. Faktorovičius**

*JSC Viltechmeda, Kalvariju str. 125, LT-08221, Vilnius, Lithuania, e-mail: faktor@aitecs.com*

### Introduction

As technology level increases, modern medicine becomes inconceivable without complex electronic devices and their systems, and these become more and more reliable and sophisticated. Modern electronic devices are reliable, they rarely brake down, and the risk of electric shock or any other injury for the patient and caregiver is vanishingly small. On the other hand, the problem of personnel working with electronic equipment becomes relevant [1]. It is impossible to “improve” the operator; therefore the amount of mistakes he makes will always be relevant. For example, major part of patient deaths occurs due to wrong administration of drugs – about 50% of all deaths [2], so only increasing the reliability of electronic medical systems software and hardware will not solve the problem. It is needed to reduce the amount of tasks the operator performs in order to reduce the amount of mistakes the operator makes, and this can be reached by creating closed loop systems. Closed loop systems would mostly be beneficial to these cases, where manual constant parameter checking and adequate response is required, such as anesthesia, glycaemic control, blood pressure control and others. Closed loop systems allowing nurses spend more time for care, where human contact between nurse and patient is very important.

The critically ill patients often require administration of drugs to regulate key physiological variables, such as level of consciousness, heart rate, blood pressure, ventilatory drive, etc., within desired targets. The rate of administration of these drugs is critical, requiring constant monitoring and frequent adjustments. Open-loop control (manual control) by clinical personnel can be tedious, imprecise, time-consuming, and sometimes of poor quality. Hence, the need for active control (closed-loop control) in medical systems is significant, with the potential for improving the quality of medical care as well as curtailing the increasing cost of health care [3].

### Challenges of closed loop system development

Despite the increased reliability of technology, there are still challenges to overcome:

- **Interface** – since closed loop systems require less attention from the staff, in case of errors, the data must be displayed very clearly and easy to understand. The interface of closed loop medical system must be a part of “fail safely” strategy, ensuring any faults are noticed and corrected, with no or as little as possible harm done to the patient.
- **Accurate mathematical models** for characterizing the dynamic behavior of drugs on physiological variables. System nonlinearities, model parameter variations from patient to patient, as well as parameter variations within the same patient under different conditions make it very challenging to develop models and effective control law architectures for active drug delivery systems [3].
- **Open loop control** option – the pattern of the treatment is different for each patient, there are many unpredictable events and even a possibility of system failure. For these reasons, the system must have a manual control, so that in treatment variations the physician could have an ability to manually control the system.
- **Data gathering and handling** – in most cases, statistical data and its analysis would give better understanding about human body functioning, successful treatment presumptions, early signs of patient state impairment and etc. Closed loop systems must be able to gather such data, so that its mathematical models could be corrected according to it.
- **Appropriate performance variable** for control – for example, sedation is typically assessed using subjective ordinal scales that distinguish between patients who are unresponsive or responsive only to noxious stimuli and those who respond to voice and are calm and cooperative in this response [3].
- **Biosensors** – sensors, used in closed loop systems must meet long-term stability, inflammatory (biofouling)

processes, calibration, selectivity, oxygen dependence, miniaturization, communication, and power requirements [4].

- **Standards and regulations** – at this time, most of the standards strictly require that medical systems should be open loop and only operator can give final decisions. This might be slowing the development of such systems, and the difficulties to formally validate the ones that are already being developed are stopping them from entering the market. While it is beneficial in terms that it might help increase the reliability and effectiveness of such systems, it also might discourage otherwise willing companies from developing such systems at all.

### Examples

**McSleepy** - using these three separate parameters and complex algorithms, the automated system calculates faster and more precisely than a human can the appropriate drug doses for any given moment of anesthesia. “McSleepy” assists the anesthesiologist in the same way an automatic transmission assists people when driving. As such, anesthesiologists can focus more on other aspects of direct patient care. An additional feature is that the system can communicate with personal digital assistants (PDAs), making distant monitoring and anesthetic control possible. In addition, this technology can be easily incorporated into modern medical teaching programs such as simulation centers and web-based learning platforms.

*Minime Medtronic or Abbott Inc.* integrate the glucose sensing element with a data processing and energy source for optimal delivery of insulin. The pager-sized glucose monitor thus transmits its data straight to the insulin pump that uses a computer algorithm to calculate the rate and timing of insulin release for optimal therapeutic intervention. Such systems offer a 3–5-day period of subcutaneous glucose monitoring, with measurement of tissue glucose every 3–5 min. An alarm capability is included to alert the individual of very low or high glucose levels. One attractive approach to implement such closed-loop system is to use two easily replaceable communicating patches (on the skin), one with the implanted sensor–amplifier–transmitter and the second with the RF receiver, insulin reservoir, a pump, battery, and subcutaneously implanted drug implant [4].

*Ventilation* - all the ventilatory modes currently used during mechanical ventilation function with closed loops. Even a ‘simple’ mode such as pressure support ventilation uses rules to initiate the pressurization, to determine the pressurization slope, to end the pressurization, to regulate the flow within the cycle, and to open the expiratory valve [5].

*Diagnostic tools* – various methods are being developed to help physicians deal with a huge amount of data and to diagnose diseases more quickly and accurately. For example, automatic medical image diagnosis can reach the accuracy of more than 97% [6, 7]. This leads physicians towards more precise diagnosis with less labor.

To be developed - *infusion systems*. Syringe infusion pumps (SIP) are widely used in medicine; they are accurate, reliable, and common in hospitals. However, they are time consuming for the nurses, especially, when many

pumps are used for one patient. To reduce those drawbacks, syringe infusion pump systems are created, like Infusion Devices Station (IDS) from Aitecs. For time being, such systems are only for monitoring purposes only, but they could be even more beneficial if management option would be included. Remote control of SIP has been not allowed in operation rooms or intensive care units till now. But closed loop technologies can provide better performance than nurse actions, particularly in the case of drugs critical for life support and where decision must be taken within seconds. Such systems could deliver drugs to the patient, according to ones individual needs quickly and accurately, there would be no need for the nurses to check constantly on each patient, and because of more accurate drug infusion, time of the treatment could be decreased. The system could consist of such parts: (Fig. 1):

- N syringe infusion pumps, including software,  $n=(1...32)$ ;
- Sensors and biosensors;
- Infusion device rack;
- Concentrator, including firmware;
- Controller, including software;
- Bar code scanner (optional);
- Other (e.g.: connections, UPS, monitor, keyboard, mouse, etc.) [1].

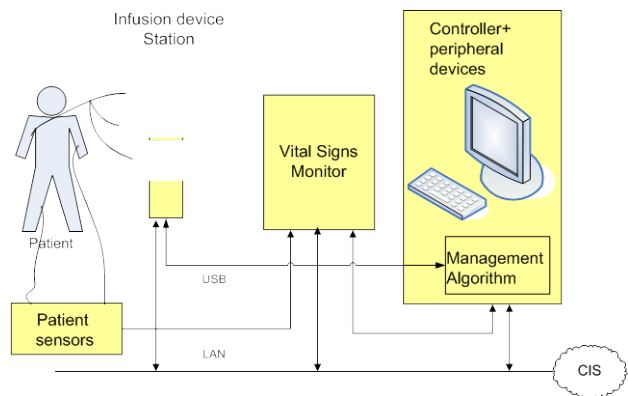

**Fig. 1.** Scheme of SIP monitoring and control system

The main difference from the existing system is the addition of the sensors and biosensors, which provide the data to the controller about the recent state of the patient. These sensors could measure blood pressure, hypnosis level, glycaemic level and etc. The new controller in the system must be equipped with accurate mathematical models for characterizing the dynamic behavior of drugs, patient reaction time and order, constrains and boundaries and other important data. According to data, gathered from these sensors and mathematical models, the controller would adjust the amount and speed of drugs delivered, so that the patient would remain in satisfactory state. This is now performed by nurses, who check on patients manually and adjust drug delivery according to their experience, intuition, physician recommendation and other subjective and objective data. These tasks increase the workload significantly, especially when patients are critically ill, and in such circumstances, the staff makes up to 17 errors a day [5]. This number could be considerably reduced by decreasing the amount of repetitive and strong attention

needed tasks, and automotive closed loop drug delivery system could be one the solutions. This is especially true, when the number of devices operators must take care of increases – more devices usually mean more mistakes made: probability  $P_{nS}$  of successful infusion (no safety hazards for the patient) using  $n$  equal syringe infusion pumps (Fig. 2)

$$P_{nS} = \prod_{i=1}^n [1 - (P_p \cdot (1 - e^{-\int_0^t \lambda(\tau) d\tau}) + P_p \cdot e^{-\int_0^t \lambda(\tau) d\tau} + (1 - e^{-\int_0^t \lambda(\tau) d\tau}) \cdot (1 - P_p))] \quad (1)$$

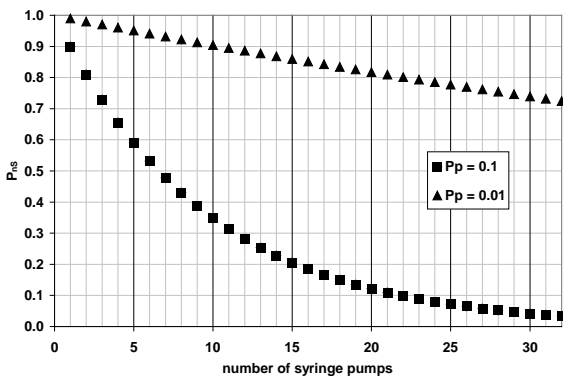

Fig. 2. Reliance between infusion reliability and number of pumps [1]

Aside from simply reducing the workload and increasing reliability, such system could have even more benefits:

- **Data** – as the new Infusion System includes a controller it could deal with a much bigger amount of data, than pumps alone, or a simple monitoring system. Such system could:
  - **register** past events, reducing the need of paperwork, which is expensive and a source of mistakes itself. Registering event logs in the system would also mean easier access to the data as it is possible to connect such system to hospitals Clinical Information System;
  - **keep and provide the data** about the patient – such important information, as patient’s allergies, drugs taken before, or simply age and weight are important for treatment, yet hard to remember. The system could warn the physician or nurse in case of doubtful drug entered and help avoid critical situations;
  - **store drug libraries** (using best hospital practice) – there are thousands of drugs in modern medicine and even more combinations of synergetic drugs, and it is impossible for a physician to remember all of them. Smart Infusion System could warn in case of synergetic drugs entered and even suggest an alternative.
  - **statistics and analysis** – gathering data is important not only for better treatment prescription, but also for correction and better understanding of human body function mathematical methods. Such data could be important not only for correction of the system itself, but even for treatment analysis for the physicians.

- **Distance** – in case of dangerous infections, or on the contrary, especially fragile patients, it is important to reduce patients contact with personnel. Closed Loop Infusion System could work on its own, reducing the need to be close to the patient.
- **Speed** – in case of critically ill patients it is important to act fast and accurate, and in such cases Closed Loop Infusion System would be very beneficial. Such system would not get tired or distracted and it could check on patient’s parameters much more often than a nurse, taking care of many patients at a time.

### Closed loop system safety

The safety of closed loop systems would mostly depend on their software and hardware reliability, thus reducing the need to evaluate the probability of human (operator) mistakes. The automation of medicine systems increases and it appears that introducing smart control or monitoring systems can help reduce the amount of mistakes made [1]. However, safety of such systems is not only a technological problem, there are also such problems as the acceptance from physicians and others, working with these systems and ethical issues. These problems could be solved by making Closed Loop Infusion system in three different levels:

- The **drug and amount** of it is prescribed, the system only determines the speed of infusion according to patient’s vital signs.
- The **drug** is prescribed, and the system determines the amount and speed of the drug infused, according to patient’s vital signs.
- **Several drugs** are prescribed and the system determines when to infuse which of them, according to patient’s vital signs.

The most important part of such system safety would be the algorithm, according to which the system decides, how the drugs should be infused. This algorithm must include all the situations that may happen in critical care and their solutions, and in case unexpected situation arises, the system must quickly and efficiently warn the nurse or the physician in order to “fail safely”. The important thing in increasing the safety of such systems overall is to determine which of the systems characteristic index  $q$  are the most important to reach the highest efficiency of the system

$$E = \varphi(\overline{q}) = \varphi(q_1, q_2, \dots, q_n). \quad (2)$$

In case such indexes  $q$  are standard and used for all electronic medical closed loop systems of the same type, it would be beneficial for designers, risk managers and users to evaluate and compare such systems.

### Conclusions

- Modern medicine would benefit a lot from closed loop systems. As modern electronics has become very secure, reliable and effective it would be wise to use those features as it is helping to reduce the amount of labor for the nurses, the number of mistakes made and the overall cost of healthcare.

- At this moment such systems must first overcome major technological challenges.
- Aside from technical difficulties, standards and verification procedures must be developed. This requires the cooperation between designers, engineers, medics and other specialists.

## References

1. **Markevičius V., Navikas D., Jonynas V., Dubauskienė N.** Risk Analysis of SIP Monitoring and Control System User Interface // *Electronics and Electrical Engineering*. – Kaunas: Technologija, 2008. – No. 7(87) – P. 85–88.
2. **Markevičius V., Navikas D.** Syringe Pump Integration Device Concept // *Electronics and Electrical Engineering*. – Kaunas: Technologija, 2007. – No. 4(76). – P. 37–40.
3. **Haddad W. M., Bailey J. M.** Closed-loop control for intensive care unit sedation // *Best Practice & Research Clinical Anaesthesiology*. – Amsterdam: Elsevier, 2009. – No. 23. – P. 95–114.
4. **Wang J.** In vivo glucose monitoring: Towards ‘Sense and Act’ feedback-loop individualized medical systems // *Talanta*. – Amsterdam: Elsevier, 2008. – No. 75. – P. 636–641
5. **Lellouche F., Brochard L.** Advanced closed loops during mechanical ventilation (PAV, NAVA, ASV, SmartCare) // *Best Practice & Research Clinical Anaesthesiology*. Amsterdam: Elsevier, 2009. – No. 23. – P. 95–114.
6. **Udrisioiu S. C., Ion A. L.** Establishing Medical Diagnosis using Pattern Semantic Rules // *Electronics and Electrical Engineering*. – Kaunas: Technologija, 2010. – No. 2(98). – P. 75–78.
7. **Patašius M., Marozas V., Jegelevičius D., Lukoševičius A.** Optimal Combinations of Color Space Components for Detection of Blood Vessels in Eye Fundus Images // *Electronics and Electrical Engineering*. – Kaunas: Technologija, 2009. – No. 3(91). – P. 53–56.

Received 2010 02 12

**N. Dubauskienė, V. Markevičius, A. Faktorovičius. Challenges of Close Loop Electronic Medical Systems // Electronics and Electrical Engineering. – Kaunas: Technologija, 2010. – No. 5(101). – P. 95–98.**

Closed loop electronic medical system issues are being analysed. The perspective of future development of medicine electronics towards intelligent interactive systems, working in automotive mode is presented. The examples of such systems are being described and the concept of closed loop infusion pump system is offered. Legal, safety and physical aspects of such systems are discussed. The reduction of patient risk during infusion due to reduction of personnel labor and human mistakes is presented. Ill. 2, bibl. 7 (in English; abstracts in English, Russian and Lithuanian).

**Н. Дубаускене, В. Маркявичюс, А. Факторовичюс. Вызовы в медицинских электронных системах с закрытым контуром управления // Электроника и электротехника. – Каунас: Технология, 2010. – № 5(101). – С. 95–98.**

Исследуются особенности медицинских электронных систем с закрытым контуром управления. Представлена дальнейшая перспектива развития медицинской электроники по направлению интеллектуальных интерактивных систем, функционирующих в автономном режиме. Представлены примеры таких систем, предложена система шприцевых насосов инфузии (СУ ШНИ), с закрытым контуром управления. Обсуждается безопасность таких систем, правовые и физические аспекты. Показано, что такие системы позволяют уменьшить риск опасности пациенту во время инфузии, при уменьшении усталости персонала и количества ошибок из-за человеческого фактора. Ил. 2, библи. 7 (на английском языке; рефераты на английском, русском и литовском яз.).

**N. Dubauskienė, V. Markevičius, A. Faktorovičius. Medicininių elektroninių sistemų su uždaru valdymo kontūru iššūkiai // Elektronika ir elektrotechnika. – Kaunas: Technologija, 2010. – Nr. 5(101). – P. 95–98.**

Nagrinėjamos medicininių elektroninių sistemų su uždaru valdymo kontūru ypatybės. Pateikta tolesnė medicininės elektronikos plėtros link intelektualių interaktyvių sistemų, veikiančių autonominiu režimu, perspektyva. Aprašyti tokių sistemų pavyzdžiai, pasiūlyta švirkštinių infuzinių siurblių sistema su uždaru valdymo kontūru. Aptariami tokių sistemų teisiniai, fiziniai ir saugumo aspektai. Parodyta, kad tokios sistemos leidžia sumažinti paciento riziką infuzijos metu todėl, kad sumažėja personalo darbo krūvis ir klaidų dėl žmogiškojo faktoriaus kiekis. Il. 2, bibl. 7 (anglų kalba; santraukos anglų, rusų ir lietuvių k.).

DOI: 10.5755/j02.eie.9442