

## System for Measuring Speed of Induction Motor

A. Petrovas, S. Lisauskas, R. Rinkevicienė

Department of Automation, Vilnius Gediminas Technical University,

Naugarduko str. 41, LT-03227 Vilnius, Lithuania, phone: +370 5 2745013, e-mails: andrius.petrovas@el.vgtu.lt, saulius.lisauskas@el.vgtu.lt, roma.rinkeviciene@el.vgtu.lt

### Introduction

Design of induction motor drives frequently meets problems of speed measurement. Speed in closed loop control system is controlled value and appear in the feedback loops [1, 2, 3]. There are some methods to evaluate motor speed: to measure directly or to apply models, calculating that. Modern induction drives use observers, calculating speed according to mathematical models of induction motors [1]. Adequacy of the model in all speed range remains the main problem.

The paper presents developed equipment for experimental speed measurement. Experiments were made at starting of motor at no load. The current transients are measured also. The goal of development of measuring equipment is obtaining results and comparing that with simulation results. The comparison will allow concluding about adequacy of induction motor model and possibility to use it for elaborating observers.

### Experimental equipment

Analyzed three phase motor is supplied by three phase voltage. For switching of three phase voltage semi-controlled keys as thyristors and symistors can be used. Symistors are chosen to simplify the electric circuit.

On the other way starting transients usually are simulated choosing one of phase voltages crossing a zero, i.e., at this voltage changing its polarity. Transients of electromagnetic torque and speed do not depend of voltage phase at switching [1], but the phase currents depend on it. Elaborated electric equipment includes electric circuit, switching motor at the instant of phase voltage crossing the zero is suitable to perform experiments and compare that with simulation.

The block diagram of designed equipment is shown in Fig. 1.

Block diagram (Fig. 1) comprises power, informational and measurement parts. Power parts are represented by induction motor under investigation and symistor relay, switching on and out supply of three phase network.

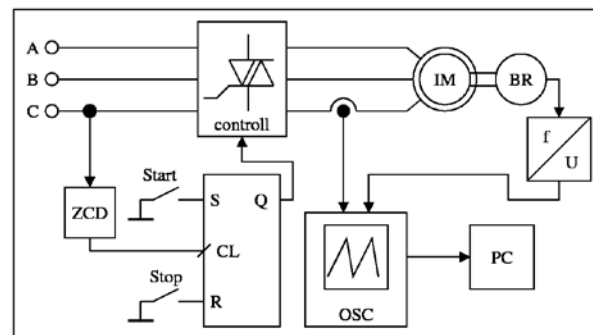

Fig. 1. Block diagram of experimental equipment

Control part of the circuit is devoted to generate controlling pulses for symistor relay. It comprises the crossing zero into negative direction identification circuit ZCD, synchronous trigger, controlled by positive fronts of pulses and control buttons “Start” and “Stop”. ZCD circuit generates pulse each time at phase C crosses the zero. Pressing buttons “Start” or “Stop”, RC trigger keeps in memory which of them is pressed down, but the trigger Q output signal does not change, while synchronizing impulse will not come from ZCD. Therefore despite of case which the button will be pressed, control part of symistor relay produces pulses at the C phase voltage crossing zero instant. This circuit synchronizes only starting of the motor, because symistor cannot be switched out without additional means.

Measuring part of the circuit is devoted to measure transients of speed and current. At the ideal case the voltages should be measured, but assumption of motor starting at voltage crossing zero leads to getting the voltages defined. The motor current can be measured using current transformer or shunt dependently on motor power.

Motor speed is measured by digital tachometer BR. In the output of this device pulse signals are produced, whose frequency is proportional to rotational frequency of rotor. The principle of operation is based on counting optical or magnetic marks on rotating discs. Due to absence of contacts between rotating parts, similar tachometers have advantages against other types of

rotating tachometers based on principles of electric machines, nevertheless they have smaller accuracy at small speed range. The article presents experimental speed investigation of motor at starting at no-load; therefore the accuracy at the beginning of the starting is not very important. To facilitate recording of the signal, the frequency-voltage converter is employed in speed measuring channel. In this way the speed is transformed into voltage amplitude.

Both current and speed signals are analogical. They should be digitized before entering a computer. In order to simplify equipment and transfer measuring results to computer, the digital two channel oscilloscope having junction witch computer, is used.

Control and power parts are mounted on the same PCB. The photo of the top view of PCB is shown in Fig. 2.

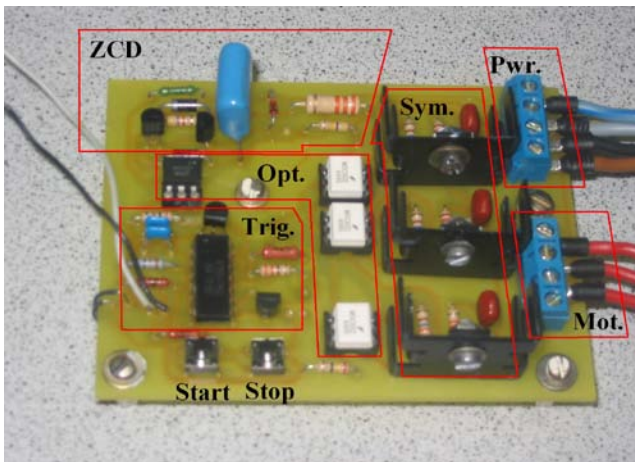

**Fig. 2.** Control part of experimental equipment

The ZCD is made from discrete parts despite a market proposes specialized microchips with integrated voltage zero crossing detection circuit for control of thyristors and symistors. Company “Fairchild semiconductor” produces similar microchips MOC303xM and MOC304xM [4]. Nevertheless in the measuring device these microchips can be hardly applied due two reasons. The first of them is requirement to switch on all symistors as the voltage in the phase C crosses zero. Application of MOC microchips allows in a simple way to switch on symistor, whose voltage crosses zero, but it is difficult to switch on synchronously the symistors of other phases. On the other hand, application of these microchips requires direct measurement of voltage or designing the special circuit to determine which proper phase was switched on.

Another widely used method to detect instant of voltage crossing zero is application of transformer. The primary winding of transformer usually is connected to phase voltage and the secondary is connected to input of comparator. Obvious advantage of this solution is simplicity and reliability. Disadvantage appears in unknown phase shift between the voltages of primary and secondary windings. It depends on transformer power, construction, load currents and other factors. The other shortcoming is related with design of comparator circuit due to necessity of two-pole supply source for comparator.

For synchronizing of control buttons pushing and zero crossing events integrated circuit 74LS74 was used. In the Fig. 2 it could be seen in the area “Trig”. 74LS74 integrates two dual D type positive edge-triggered flip-flops. The one of them is running as common RS trigger and represent the stage of control buttons. To set this trigger button “Start” should be pressed. To reset this trigger the button “Stop” should be pressed. Another trigger is running as synchronous D trigger and synchronizes the control buttons pushing with zero crossing events.

The “Sym” in the Fig. 1 denotes the area where three power symistors are mounted. Each one can drive the current up to 4 A, therefore using of heat sinks are necessary. Near to the symistors the power “Pwr.” and motor “Mot” terminals are placed.

ZCD and power symistors work under voltage of 380 V therefore they should be isolated from control circuit. For isolation of zero crossing signals 4N35 optocoupler is used. For isolation of control signals from power symistor the MOC3022 photosymistors are applied. All these devices are showed in “Opt” area in Fig. 1.

The photo of experimental equipment during the experiment is presented in Fig. 3.

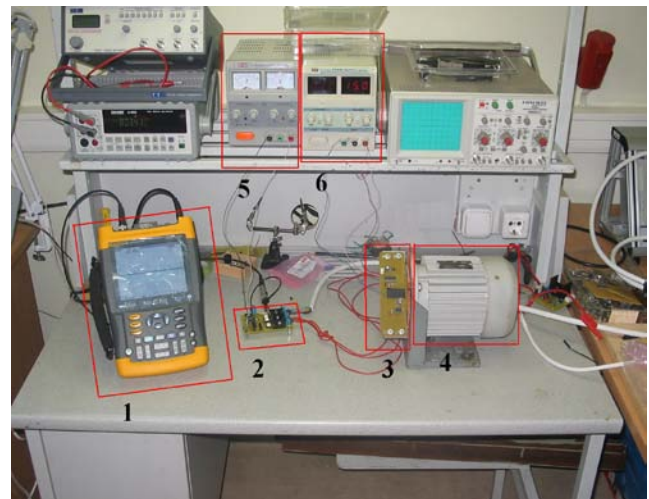

**Fig. 3.** Experimental equipment: 1 – oscilloscope; 2 – symistor relay; 3 – digital tachometer; 4 – induction motor; 5 – supply source of control part; 6 – supply source of digital tachometer

The oscilloscope 1 is connected to the computer.

## Experimental results

The inductor motor 4AA63AU45 was chosen for experiments. It is the industrial small power induction motor, whose specification and equivalent parameters can be found in reference books. Its catalogue data are given in Table 1.

Designed synchronizer connects the motor to three phase supply at time instant when C phase voltage crosses zero forward negative direction. Experimental transients of stator C phase voltage and current are presented in Fig. 4.

Due to special oscilloscope triggering, the transients start at time not equal to zero.

**Table 1.** Data of induction motor

Parameter	Value	Notes
Rated power $P_n$ , W	250	
Supply voltage $U$ , V	220/380	Winding connection $\Delta/Y$
Rated current $I_f$ , A	1,49/0,86	Winding connection $\Delta/Y$
Power factor $\cos\phi$	0.68	
Efficiency $\eta$ , %	65	
Number of pole pairs	2	Used in the model
Rated speed $n_n$ , rpm	1380	Synchronous speed 1500 rpm
Inertia $J_r$ , $\text{kg}\cdot\text{m}^2$	$12,4\cdot 10^{-4}$	Used in the model

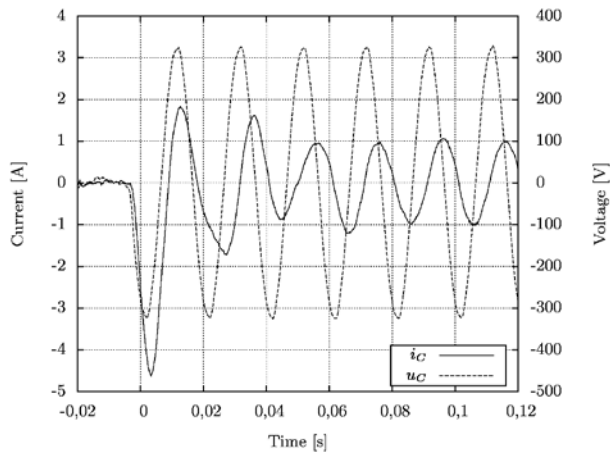
**Fig. 4.** Experimental transients of stator C phase voltage and current

The experiments indicate good corresponding to catalogue data. At delta connection of windings according to name table data phase current should be 0.86 A (amplitude about 1.2 A). Measured value is about the same. At starting current exceeds steady-state approximately five times. The settling time is about 0.8 s. All experiments were made at no load.

Simulation of induction motor transients was based on solving of motor equations in phase reference frame [5, 6]. The same results can be obtained using models in transformed coordinate system. Coefficients, entering system of differential equations of induction motor, were calculated according to catalogue data of equivalent T-circuit. Simulation results of current transients at no load and with rated load are presented in Fig. 5.

Comparison Fig. 4 and Fig. 5 shows difference between simulated and experimental currents and settling time when motor is starting at no load.

It can be explained by the following reasons:

1. for simulation is used idealized model of motor, where nonlinearities of magnetic circuit and saturation due the great starting currents are neglected;
2. the nameplate of the motor gives data for rated mode, but experiments were made with motor starting at no load;
3. model does not include leakage fluxes and the current producing that.

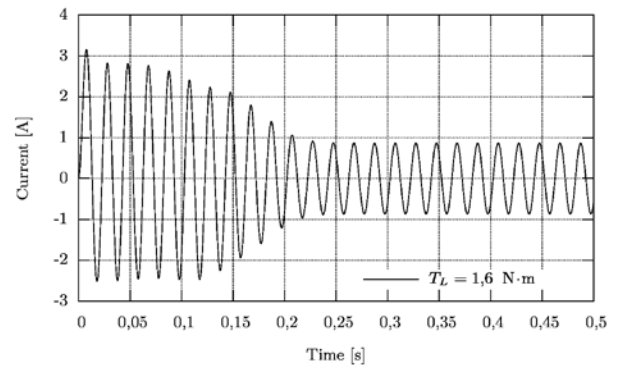
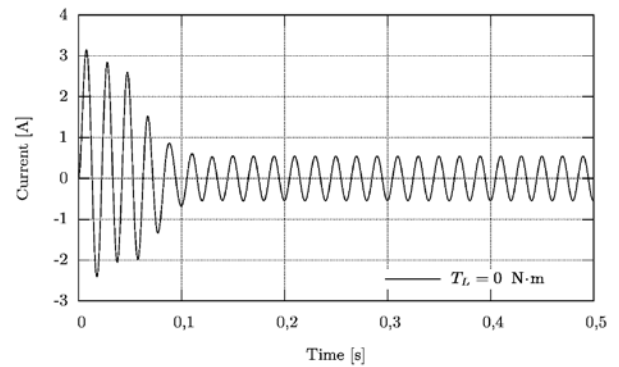
**Fig. 5.** Simulation results of current transients at no load and with rated load

The general, it is possible to state that models, which does not consider saturation and are based on parameters of motor, calculated from rated data, cannot be applied for quantitative analysis. As exception can be situation with soft motor starting. Steady-state current at motor starting at no load is equal to 0.6 A, but simulation gives error about 30%. Simulation of motor transients at rated load gives current RMS value 0.7 A; i. e. error is equal to 15%. The smaller error could be expected due to motor heating and increasing resistance of windings at starting with load.

Experimental results of speed transients are presented in Fig. 6. The transient process lasts approximately 0.15 s.

Simulation results of speed transients at different load torque are shown in Fig. 7.

Comparison of experimental measured and simulated speed transients indicates significant error at the beginning of the process. Error between experimentally measured and simulated steady-state speed does not exceed 5%.

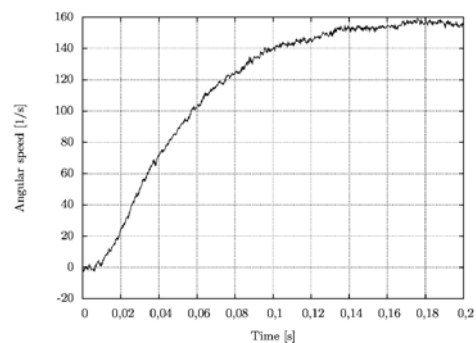
**Fig. 6.** Speed transients at starting (experimental)

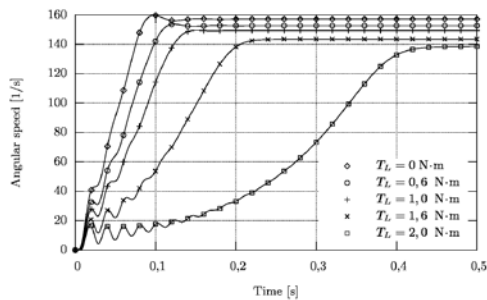

Fig. 7. Simulation results of speed transients

## Conclusions

1. Developed equipment meets requirements and allows connecting to the network the motor or any three-phase circuit at the time instant of voltage crossing zero forward negative direction.
2. Delay of load switching is about 140  $\mu$ s.
3. Experimental starting transients of speed and current differ from simulated those at small speed of rotor. It can be stated that rated parameters, used to elaborate Simulink model do not match experiments at small speed.
4. Error between experimental and simulated steady-state currents does not exceed 15%.

5. Error between experimentally measured and simulated steady-state speed does not exceed 5%.
6. Comparison of experimental and simulated results indicates that induction motor model, elaborated on the base of rated parameters is suitable to calculate speed transients of motor, operating just at rated mode.

## References

1. **Bimal K. Bose.** Modern Power Electronics and AC Drives. – New Jersey: Prentice Hall PTR, 2002. – 738 p.
2. **Schröder D.** Elektrische Antriebe – Regelung von Antriebssystemen. – Springer, 2009. – 1336 p.
3. **Rinkevičienė R., Petrovas A.** Modelling of Frequency controlled induction drive with ventilator load // Electronics and Electrical Engineering. – Kaunas: Technologija, 2009. – No. 6(94). – P. 69–72.
4. <http://www.fairchildsemi.com/ds/MO/MOC3041-M.pdf>
5. **Rinkevičienė R., Petrovas A., Batkauskas V., Baskys A.** Dynamics of variable speed drive // Proceedings EMD'2008, 2008. – P. 229–232.
6. **Rinkevičienė R., Baskys A., Petrovas A.** Model of Simulation of Dynamic characteristics of the System Frequency Converter – AC Induction motor // Electronics and Electrical Engineering. – Kaunas: Technologija, 2008. – No. 2(82). – P. 65–68.

Received 2010 03 15

**A. Petrovas, S. Lisauskas, R. Rinkevičienė.** System for Measuring Speed of Induction Motor // Electronics and Electrical Engineering – Kaunas: Technologija, 2010. – No. 5(101). – P. 27–30.

The article presents description of elaborated equipment for measurement of induction motor speed and current transients. Experimental results of motor current and speed at motor starting without load are measured and compared with simulated that. Results of comparison are used to determine adequacy of the induction motor model. It is stated, that model of induction motor, elaborated according to calculated coefficients, based on the rated parameters of the motor, is not enough adequate in the beginning of transients, where motor currents and speed are simulated with great errors. Il. 7, bibl. 6, tabl. 1 (in English; abstracts in English, Russian and Lithuanian).

**А. Петровас, С. Лисаускас, Р. Ринкявичене.** Система измерения скорости асинхронного двигателя // Электроника и электротехника. – Каунас: Технология, 2010. – № 5(101). – С. 27–30.

Обсуждается оборудование для экспериментального измерения переходных процессов тока статора и скорости ротора при пуске асинхронного двигателя на холостом ходу. Результаты, полученные в ходе эксперимента, сравниваются с переходными процессами, полученными при помощи математического моделирования. Результаты сравнения используется для оценки адекватности математической модели асинхронного двигателя. Установлено, что модель, в которой используется коэффициенты для номинального режима работы, не вполне адекватна в начале переходного процесса. Ил. 7, библи. 6, табл. 1 (на английском языке; рефераты на английском, русском и литовском яз.).

**A. Petrovas, S. Lisauskas, R. Rinkevičienė.** Asinchroninio variklio greičio matavimo sistema // Elektronika ir elektrotechnika. – Kaunas: Technologija, 2010. – Nr. 5(101). – P. 27–30.

Straipsnyje aprašyta asinchroninio variklio greičio ir srovės pereinamųjų procesų matavimo įranga. Eksperimentiškai gauti variklio, paleidžiamo tuščiaja veika, srovės ir greičio pereinamieji procesai. Eksperimentiškai gauti rezultatai palyginami su gautais imitavimo rezultatais. Palyginimo rezultatai naudojami asinchroninio variklio modelio adekvatumui nustatyti. Nustatyta, kad, paleidžiant variklį, pagal nominaliajam darbo režimui apskaičiuotus jo parametrus sudarytas modelis pradžioje neduoda tikslių greičio pereinamojo proceso rezultatų. Il. 7, bibl. 6, lent. 1 (anglų kalba; santraukos anglų, rusų ir lietuvių k.).

DOI: 10.5755/j02.eie.9402