

## Testing of the Superconducting Magnets Frequency Characteristics

D. Świsulski, M. Wołoszyk, M. Wołoszyn, M. Ziółko, L. Rafiński

Gdańsk University of Technology, Electrical and Control Engineering Faculty,  
ul. Narutowicza 11/12, 80-233 Gdańsk, Poland, phone +48 58 3471397, e-mail: dswis@ely.pg.gda.pl

A. Stafiniak

GSI Helmholtz Centre for Heavy Ion Research GmbH,  
Planckstraße 1, 64291 Darmstadt, Germany, phone +49 6159710, e-mail: a.stafiniak@gsi.de

### Introduction

The use of superconducting magnets allows to build large energy particle accelerators with a good magnetic field power and running cost ratio. One of those is the Large Hadron Collider (LHC) at CERN (fr. Conseil Européen pour la Recherche Nucléaire), Geneva which is working since 2008. Superconducting magnets will also be used in the FAIR (Facility for Antiproton and Ion Research) project. This new facility will be build in GSI Helmholtz Centre for Heavy Ion Research GmbH, Darmstadt, Germany.

Superconductive magnets are characterized by minute resistance at relatively huge inductivity (from mH up to H). Standard measurement methods cannot be used to test them at cold condition [1].

Based on CERN experience, the authors have constructed a dedicated measurement system intended for the measurement of the parameters of the tested magnet [2]. Those parameters can be measured using DC and AC mode (at different frequencies). The main hardware parts are a gain-phase analyzer and a power amplifier. Authors proposed a method to recalculate the equivalent parameters (RLC) of the magnet. The system is controlled by special software written in National Instruments LabVIEW.

### System structure

The measurement system for the testing of the superconducting magnet parameters is build using the SI 1253 Gain-Phase Analyzer, and an KEPCO model BOP 100-4M-4886 power supply/amplifier.

The base task of the system is testing the frequency function of the magnet coil impedance (and its components), and testing the resultant coil-to-ground impedance. The diagrams that allow for the realization of those functions are shown at Fig. 1.

A PC, the main control device of the measurement system, is enforcing a signal from the generator. The signal

from the generator (a part of the SI 1253 gain-phase analyzer), is applied to the KEPCO power amplifier. The amplification rate of this circuit is controlled by a special configuration key or by applying specific resistance to the amplifier input.

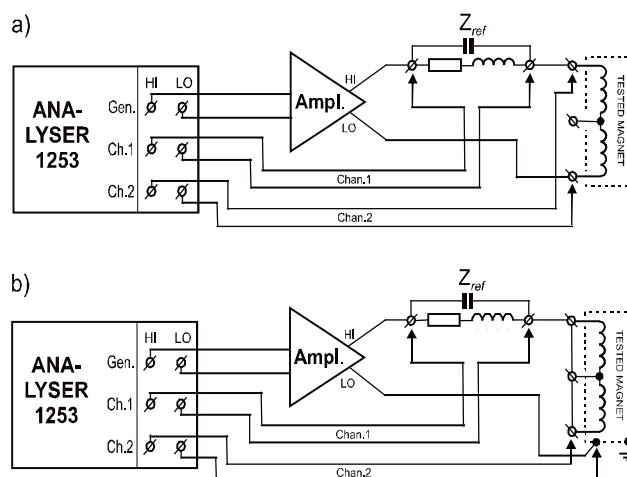

Fig. 1. The diagrams for the testing of the frequency function of the: a – coil impedance; b – coil-to-ground impedance

If there is a need for the measurement system to be placed at long distance from the tested magnet and long connectors have to be applied, then, to ensure the precision of the signal applied to  $Z_{ref}$  and tested magnet, the connectors have to be conFig.d using the 4-wire schematics (using the SENSING terminal of the amplifier), shown at Fig. 2.

The amplified signal is applied to the, serially connected, reference impedance (resistance)  $Z_{ref}$  and the tested magnet. The voltage drop at the reference impedance and at the tested magnet coil (or between the coil and ground) is tested by the two channels of the SI 1253 analyzer. Orthogonal components of voltage drops are measured. The PC stores both of the measurements at the same time.

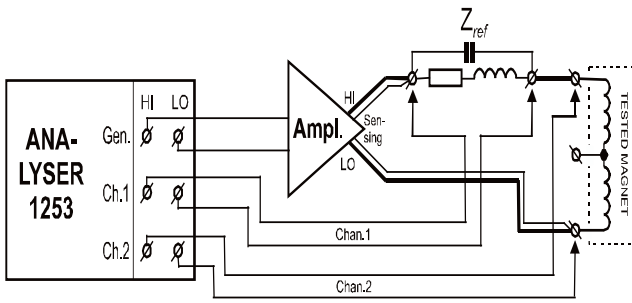

Fig. 2. The schematics for the 4-wire connection, using the “SENSING” terminals

The system uses the GPIB interface for communication. There is a dedicated communication card in the PC that acts as the main interface controller. The authors have constructed special drivers for the National Instruments LabVIEW system to be used with the SI 1253 model analyzer and the KEPCO amplifier.

Taking into account the limited resolution of the analyzer, a proper relation between the tested magnet and reference impedance must be maintained. As the tested magnet is characterized by large inductivity its impedance largely depends on frequency, and is rising rapidly along with it. The larger impedance means a smaller current flowing through the tested magnet and the reference impedance, which means a small voltage drop at the reference impedance, as the  $Z_{ref}$  impedance isn't as largely dependent on frequency. In some cases, the voltage drop at  $Z_{ref}$  can be many times smaller than the smallest voltage measurable by the analyzer, and that will cause the voltage measurements to have small resolution. The impedance is calculated taking into account both the tested magnet and reference impedance voltage drops (as a relation between those two), so the small resolution error can have a huge impact on the exactness of the measurements results.

### Software

The software of the system was made with the National Instruments LabVIEW system [3]. After starting the program, the user is presented with a set of seven tabs: Configuration (for configuring the measurement system), Connecting (showing the required system connections), Setup (for configuring the test parameters), Measurement (for starting the measurement, saving the results and loading prior results), Results of calculations (for making RLC parameters calculations and viewing their results), Generate AC/DC (for configuring the generator to supply a constant AC or DC signal) and About (with some information about the authors). The main configuration options (the RLC parameters of the reference impedance, the amplification rate, the model of the magnet used in calculations and the voltage supplied by the system) are shown constantly at the left side of the program window.

The Configuration tab is shown at Fig. 3. It is used to set the basic information about the tested magnet and system configuration, and also the model of the magnet impedance used in later calculations.

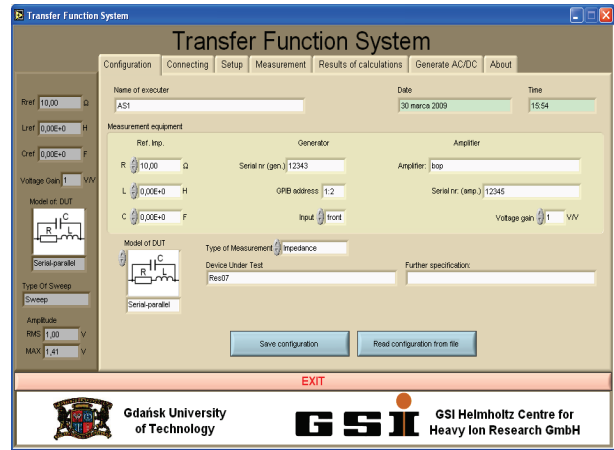

Fig. 3. The Configuration tab

The Measurement tab is used to perform the test, save its results to a file or to load a prior test file (Fig. 4). After a completed test, the data from the analyzer is shown in a table on the right side of the tab.

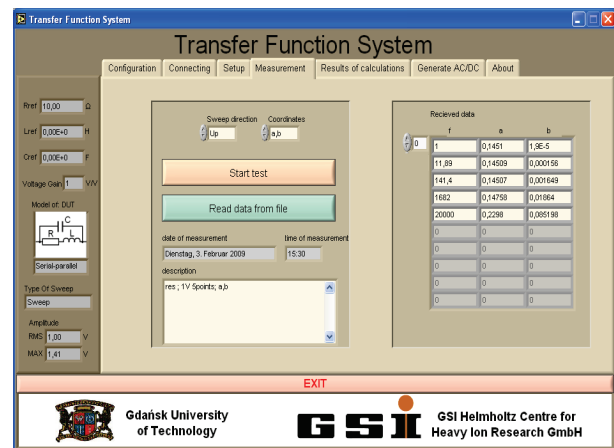

Fig. 4. The Measurement tab

For performing the calculations and to view their results the user has to use the “Results of calculations” tab (Fig. 5).

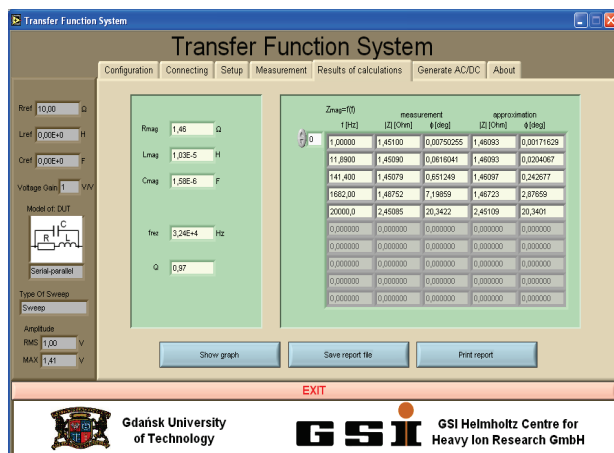

Fig. 5. The Results of calculations tab

The results of RLC parameters calculation, using the conFig.d magnet model, are presented on the left. Those are: the resistance  $R$ , inductance  $L$ , capacitance  $C$  and also resonance frequency  $f_{rez}$  and the  $Q$ -factor. On the right side, there is a table showing the calculated, taking into account the data from the analyzer and the reference impedance, module and phase of the impedance and the frequency of the measurement signal. Also there is the module and phase calculated for the RLC model, using the prior calculated model parameters. After clicking the Show graph button, a new window will open showing those results as a graph.

The frequency function of the tested magnet module and phase is calculated using the measurement data. Next the equivalent RLC parameters are calculated.

After  $k$  measurements with different frequencies, we get the frequency function of the tested magnet voltage  $U_{1i}$  and the reference impedance voltage  $U_{2i}$  relation ( $I = 1 \dots k$ )

$$\frac{U_{1i}}{U_{2i}} = a_i + j \cdot b_i. \quad (1)$$

This relation is equal to the relation of the impedance of the tested magnet  $Z_{mi}$  and the reference impedance  $Z_r = a_r + j \cdot b_r$ , at  $i$  frequency

$$\frac{U_{1i}}{U_{2i}} = \frac{Z_{mi}}{Z_r}. \quad (2)$$

From the equation (2) we can get the real  $A_i$  and imaginative  $B_i$  component of the admittance of the tested magnet at  $k$  measurement frequencies

$$Y_{mi} = \frac{1}{(a_i + jb_i)(a_r + jb_r)} = A_i + jB_i. \quad (3)$$

Assuming the serial-parallel model of the superconducting magnet coil (serial  $RL$  parallel with  $C$ ), the admittance of the model is given as

$$Y_{mi} = \frac{1}{R + j\omega_i L} + j\omega_i C = \frac{R}{R^2 + (\omega_i L)^2} - j\omega_i \left[ \frac{L}{R^2 + (\omega_i L)^2} - C \right]. \quad (4)$$

From the equations (3) and (4) we get two equations with three unknown factors ( $RLC$ )

$$A_i = \frac{R}{R^2 + (\omega_i L)^2}, \quad B_i = -j\omega_i \left[ \frac{L}{R^2 + (\omega_i L)^2} - C \right]. \quad (5)$$

Theoretically, the measurement can be made using only two frequencies  $\omega_i$ , and the model parameters will be calculable. Taking into account the limited resolution of the measurement device, measurement noise, the exactness of the used reference impedance and the relation of the resistance  $R$  and the inductive  $\omega L$  and capacitive  $1/(\omega C)$ , reactance, the calculation using only choosen frequencies wouldn't be exact enough. Taking that into consideration,

the square root approximation was selected to be used for calculating the model parameters.

Using the first equation of (5) we get

$$R + \omega_i^2 \frac{L^2}{R} = A_i^{-1}. \quad (6)$$

Substituting  $x_i = \omega_i^2$  we get

$$R + x_i \frac{L^2}{R} = A_i^{-1}. \quad (7)$$

Using square root regression for  $k$  sets of  $(x_i, A_i)$  we calculate the  $m$  and  $n$  coefficients of the polynomial  $y = mx + n$ . Using those we get the resistance  $R$  and inductance  $L$  of the model

$$R = n, \quad L = \sqrt{mR}. \quad (8)$$

The capacitance  $C$  is calculated using the second equation of (5)

$$C = \frac{B}{\omega_i} + \frac{L}{R^2 + (\omega_i L)^2}. \quad (9)$$

A similar method is used to calculate the  $RLC$  parameters of the parallel model of the magnet.

### Example test results

The discussed system is used at the GSI Helmholtz Centre for Heavy Ion Research for testing superconducting magnets. Fig. 6 shows a magnet at warm condition being tested. The measurement instruments are visible on the right.

For the presented magnet, the measured voltage relation, given by the equation (1), is shown in Table 1.

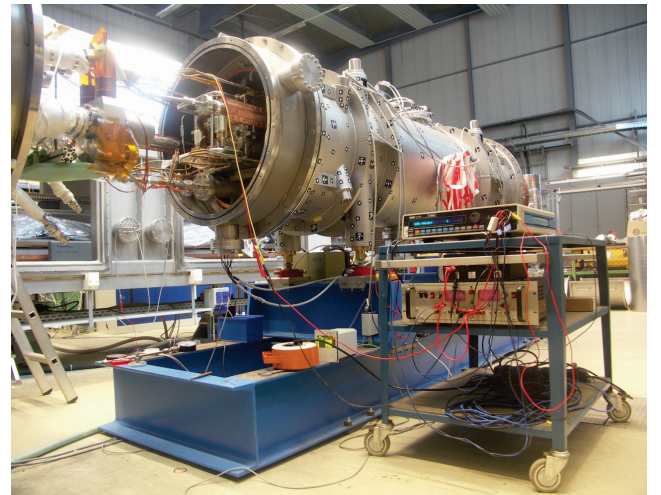

Fig. 6. A superconducting magnet being tested at GSI, Darmstadt

Using this measurement data and the shown algorithm, equivalent RLC parameters of the model were calculated:  $R = 0.509 \Omega$ ,  $L = 2.04 \text{ mH}$ ,  $C = 2.70 \mu\text{F}$ ,  $f_{rez} = 2.14 \text{ kHz}$ ,  $Q = 54.0$ .

**Table 1.** Example test results of a superconducting magnet

$f$ [Hz]	$a$	$b$
1.0000	0.101700	0.002576
1.6680	0.101700	0.004289
2.7830	0.101710	0.007147
4.6400	0.101710	0.011916
7.7400	0.101730	0.019864
12.9200	0.101750	0.033152
21.5400	0.101840	0.055254
35.9400	0.102070	0.092184
59.9000	0.102700	0.153580
100.0000	0.104370	0.256230

To verify the results, a graph of the frequency function of the module and phase of the tested magnet, calculated using the measurement data in table 1 and equation (2), and its approximation, the frequency function of the module and phase of the RLC model with the prior calculated parameters, was constructed (Fig. 7).

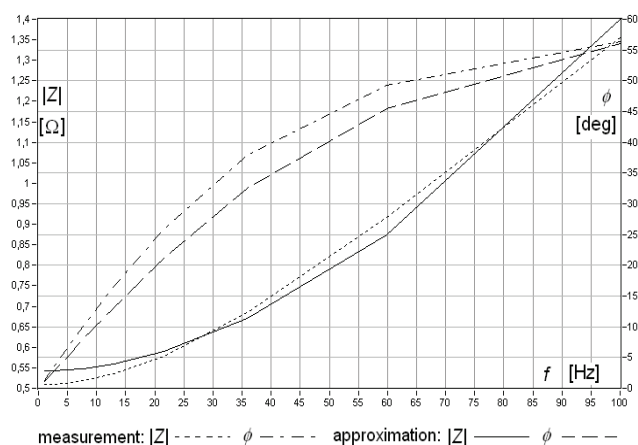

**Fig. 7.** The frequency function of the module and phase of the tested magnet and its calculated model

There is a good correspondence between the modules and a small error with the phase, which is sufficient to verify that the  $RLC$  calculations using the shown method were correct.

## Conclusions

The constructed measurement system is used to test the coils of the superconducting magnets at GSI Helmholtz Centre for Heavy Ion Research, Darmstadt, Germany.

First tests gave good results. The system is meant to be used for the measurement of the magnet frequency characteristics and other parameters during pre-series and series production of the superconducting magnets. This system will also be used during the procedure of equilibration of the quench detection bridge.

The authors see a need to upgrade the system in the area of calculating the  $RLC$  parameters of the equivalent model for larger range of frequency (up to 20 kHz). Different reference impedances for different measurement types have to be built and tested. Additional models of the measured objects can also be implemented.

## References

1. Jaccard Y., Theron R., Jeanneret B., Meyer R., Leemann C., Martinoli P. AC impedance measurements of twodimensional superconductors // IEEE Transactions on Applied Superconductivity. – 1993. – Vol. 3. – Iss. 1. – P. 1640–1642.
2. Jabben L. CERN LHC/ICP Technical Note PROMIT. – October, 1998.
3. Świsulski D. Komputerowa technika pomiarowa. Oprogramowanie wirtualnych przyrządów pomiarowych w LabVIEW. – Warszawa, Agenda Wydawnicza PAK, 2005. – 212 p.

Received 2010 03 23

**D. Świsulski, M. Wołoszyk, M. Wołoszyn, M. Ziółko, L. Rafiński, A. Stafiniak. Testing of the Superconducting Magnets Frequency Characteristics // Electronics and Electrical Engineering. – Kaunas: Technologija, 2010. – No. 7(103). – P. 39–42.**

The paper shows some of the most notable difficulties connected with constructing a superconducting magnets frequency characteristics test system. The hardware and software of the system was shown, and the method of calculating the model of the magnet coil parameters. The paper shows some of the test results of example superconducting magnets. Ill. 7, bibl. 3, tabl. 1 (in English; abstracts in English, Russian and Lithuanian).

**Д. Швисулски, М. Волошик, М. Волошин, М. Зиолко, Л. Рафински, А. Стафиняк. Исследование частотных характеристик сверхпроводных магнетов // Электроника и электротехника. – Каунас: Технология, 2010. – № 7(103). – С. 39–42.**

Описываются способы анализа частотных характеристик магнетов. Для анализа предложена оригинальная программа и технические средства. В качестве примера дана модель расчета магнитной катушки и экспериментные расчеты системы. Ил. 7, библи. 3, табл. 1 (на английском языке; рефераты на английском, русском и литовском яз.).

**D. Świsulski, M. Wołoszyk, M. Wołoszyn, M. Ziółko, L. Rafiński, A. Stafiniak. Superlaidžių magnetų dažninių charakteristikų tyrimas // Elektronika ir elektrotechnika. – Kaunas: Technologija, 2010. – Nr. 7(103). – P. 39–42.**

Aprašyti didžiausi sunkumai, su kuriais susiduriama tiriant superlaidžių magnetų dažnines charakteristikas. Pasiūlyta programinė ir techninė įranga bei metodas magnetinės ritės modelio parametrų apskaičiuoti. Pateikti kai kurie testuojamų sistemų rezultatai. Il. 7, bibl. 3, lent. 1 (anglų kalba; santraukos anglų, rusų ir lietuvių k.).

DOI: 10.5755/j02.eie.9272