

Efficiency of PFC Operating in Spread Spectrum Mode for EMI Reduction

J. Jankovskis, D. Stepins, D. Pikulins

Faculty of Electronics and Telecommunications, Riga Technical University,

Azenes str. 12 – 407, Riga, LV-1048, Latvia, tel. +371 7 089 213; e-mail: jankovsk@rsf.rtu.lv

Introduction

As all-around tendency of consumed power lowering is escalating on still higher efficiency is needed in all fields of energy utilization. Considerable positive contribution to this in the section of electric power is coming from electronics in which in short span of few last decades power supply has changed from linear to switch mode power supply (SMPS) thus allowing radically to increase efficiency (typically several times). Although the full-load figures of efficiency now are rather high (as a rule at the grades of Energy Star program [1]) they are accompanied by high level of electromagnetic interferences (EMI) stemming from switching nature of the power regulation that creates widespread both conducted and radiated noises [2]. Additionally, in the most common cases of powering SMPS units from AC utilities there appears an interface interaction between them, reducing consumed AC power quality (PQ) coming to light as the low value of power factor (PF) [3]. The demand for high PF (e.g. standards: EN61000-3-2; IEC555 [4]) sets the need for power factor corrector (PFC) in the system (Fig.1). The use of it do improve PF, but PFC itself as a rule is switch-mode unit as well and as a such is creating additional EMI [5]. Thus the challenge is in the combination of high rate efficiency and PF (high PQ) with low EMI. The solution of this problem based on spread-spectrum applications in switch-mode PFC (boost topology) is investigated in this study.

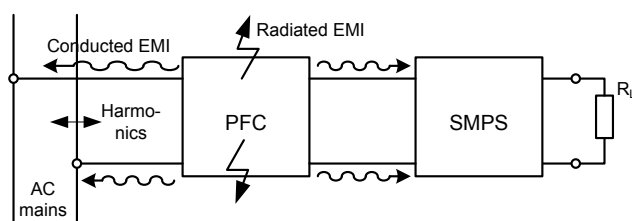

Fig. 1. Utility interface with typical power supply for DC load

Efficiency and spread spectrum technology – theory

As it was mentioned above high efficiency (η) and PQ is possible to achieve by the use of switch-mode technology throughout the power supply stage (Fig. 1) – both for PFC and SMPS unit. These high qualities are possible to combine with low EMI only if special efforts are made for EMI noise suppression. One low-cost effective method for it is the use of spread-spectrum technology (SST) [6] which is not calling for additional power components nor for their size or rating increase and which we are using in this study as well. In the process we are focusing our attention entirely on PFC since now there is broad spectrum of publications in relation to SST in typical SMPS units [7].

SST in effect means frequency modulation (FM) of the switching frequency f_{sw} of switch-type power unit. This FM broadens and suppresses each harmonic of natural discrete harmonic spectrum of unmodulated f_{sw} , converting the harmonics in corresponding bands: each harmonic is the centre of band possessing the bandwidth B_h [7] (Fig. 2. b):

$$B_h = 2f_m(1 + m_f \cdot h) = 2(\Delta f_{sw} \cdot h + f_m), \quad (1)$$

where f_m is the modulation frequency; Δf_{sw} is the peak deviation of f_{sw} from its unmodulated value; m_f is the modulation index, $m_f = \Delta f_{sw}/f_m$, and h is the number of harmonics, $h=1$ (fundamental), 2, 3, ... This modulation of natural spectrum of f_{sw} due to SST can lead to change of η (from the value fixed at unmodulated case) since for main components of PFC directly involved in energy processing (such as power: switch, diode, inductor, and capacitors) power loss in general is frequency dependent. Only in the case of domination of linear dependence of the losses there would be the compensation in average and thus the use of SST does not change η . With the goal for definite conclusions as to η due to SST the effects of loss frequency $f=f_{sw}$ specific for the components are analyzed in more details in the following.

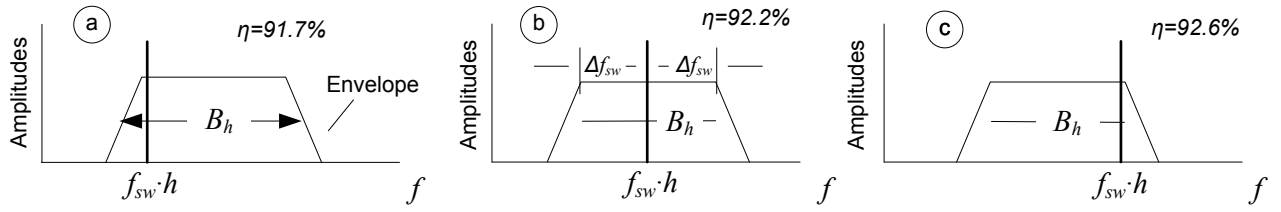

Fig. 2. Transformation of the harmonic h of the switching frequency f_{sw} into the appropriate band B_h in a consequence of FM of f_{sw} : b – for symmetrical FM; a, c – for asymmetrical ones

The losses associated with the switch include [8]: conduction loss, switching loss, turn-off state loss due to leakage current, and driving loss. Nonetheless, typically dominating are mentioned first two – conduction (ohmic), P_{cond} and switching (dynamic), P_{dyn} losses which, to a first approximation, are [9]

$$P_{cond} = I_{on}^2 R_{on} D; \quad P_{dyn} = (1/2) V I_{on} (t_r + t_f) f_{sw}, \quad (2)$$

where I_{on} is the on-current, V is the off-voltage, and R_{on} is the on-resistance of the switch; D is the duty cycle; t_r and t_f are the rise and fall times, respectively.

As to power inductor the losses are generated both by magnetic core, P_{mc} and winding, P_w . If the principle components for these losses are accounted (e.g., static hysteresis loss, classical eddy current loss, and excess loss for P_{mc} [10]; joint action of eddy and proximity effects for P_w) they can be presented

$$\begin{cases} P_w = c_w \sqrt{f_{sw}}, \\ P_{mc} = k_n f_{sw} B_m^\beta + k_c (f_{sw} B_m)^2 + k_{ex} (f_{sw} B_m)^{1.5}, \end{cases} \quad (3)$$

where k_h , k_c , k_{ex} , β , c_w are the empirical coefficients, B_m is the peak flux density. In the case of nonsinusoidal excitations (typical for SMPS) these relations (especially for P_{mc} mainly because of due account of hysteresis and excess losses) are with reduced accuracy; matching to this, P_{mc} totally is presented by empirical Steinmetz relation or its modified form [11], accordingly

$$P_{mc} = C_m f_{sw}^\alpha B_m^\beta \quad \text{or} \quad P_{mc} = C_m f_{eq}^{\alpha-1} B_m^\beta f_{sw}, \quad (4)$$

holding less number of empirical constants C_m , α , β ($1 < \alpha < 3$; $2 < \beta < 3$; typically $\beta = 2.5$); the extra parameter f_{eq} is possible to estimate for given operational conditions [10].

In the case of power capacitor loss analysis it should be noted that in boost PFC greatest influence is from the output, typically aluminum electrolytic capacitor. Power dissipated in this capacitor, P_{dis} is due to its equivalent series resistance (ESR):

$$P_{dis} = ESR \cdot I^2 = (R_{sd} + R_{md}) \cdot I^2 \quad (5)$$

where ESR components R_{sd} and R_{md} represent the losses in dielectric and metallic elements of the capacitor. In general, ESR is frequency dependent characteristic; however, in typical switching frequency region of f_{sw} (several 100kHz) experiments [12, 13] show $ESR \approx \text{const}$.

As regards to diode losses they as well are ohmic and negligible for high output voltage SMPS. Consequently, it may be concluded from Eqs. (2-5) that the total loss of PFC in relation to f_{sw} and B_m includes linear and nonlinear terms:

$$P_{PFC} = P_{const} + P_{lin}(f_{sw}) + P_{nonlin}(f_{sw}) + P_{nonlin}(B_m) \quad (6)$$

Clear domination of $P_{nonlin}(f_{sw})$ may lead to the effect that η actually depends on frequency deviation Δf_{sw} due to SST. Since it is not possible to determine the specific contribution of the components in Eq.(6) analytically both simulation and experimental test of possible effects is performed. Preliminary examination within which intentionally asymmetrical FM band B_h in relation to f_{sw} is used (Fig. 2: a, b) really points to the effect - η obviously depends on the average frequency.

Experimental setup

The experimental setup (shown in Fig. 3) is based on boost-type PFC operating in continuous conduction mode. The switching frequency $f_{sw} = 100 \text{ kHz}$, nominal output power $P_{nom} = 360 \text{ W}$ and regulated nominal DC output voltage 410 V . L4981A PWM controller is used in this PFC to control for sinusoidal processing of the input current and regulate the output voltage.

To implement FM, modulating signal from a signal generator is fed into pin 17 of the controller via an auxiliary circuit $R_g C_g$. The frequency f_{sw} is set by R_{osc} and C_{osc} [14], but frequency f_m and frequency deviation (Δf_{sw}) can be adjusted by changing frequency and amplitude of signal generator output signal [14].

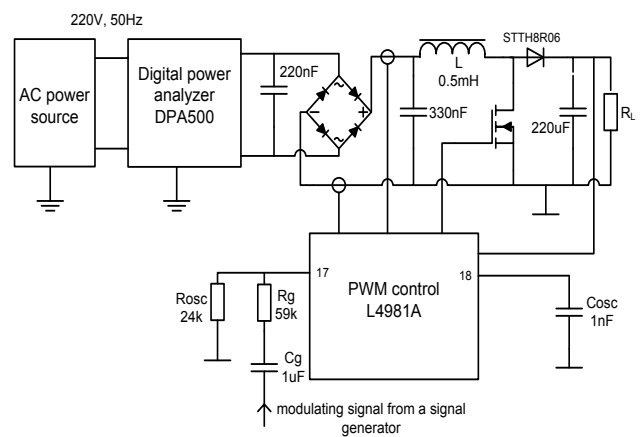

Fig. 3. Simplified schematic diagram of the experimental setup

Conducted EMI measurements are performed by the use of a spectrum analyzer (Agilent E4402B) connected to LISN (Hameg 6050-2). For efficiency η , THD and PF measurements a digital power analyzer (EM Test DPA 500) connected between a regulated AC power source and PFC under test is used.

Simulation of PFC

In our previous research [14] the PFC model was implemented by means of SymPowerSystems blockset offered by the simulation tool - SIMULINK. The control circuitry, as well as special modulated sawtooth generator, was realized using common SIMULINK blocks and Embed Matlab Function block. The mentioned virtual generator block modulated the frequency of generated sawtooth accordingly to the signal values of optional sine wave. In this investigation the model of the boost type PFC was significantly improved.

The power plant of the converter under test was implemented by means of SimElectronics blockset, as it contains very detailed and extremely precise models of switching elements (diodes, transistors), that allows taking into account nonlinearities and high-frequency dynamics associated with these components. In order to make simulations as precise as possible the parameters of transistor and diode were specified directly from the provided datasheets. The already mentioned virtual sawtooth generator was remodeled in order to extend its potential and make it possible to use also aperiodic modulating signals of any kind. The blocks allowing for THD, PF and η measurement capabilities were also developed and included in the final simulation model.

The simulations were carried out using sinusoidal modulating signal with different frequencies and deviations, as well as chaotic signal, that was obtained from the developed SIMULINK model of the logistic map. The values of modulating signal's frequency and deviation were chosen within the range defined in [14] in order to compare simulation results and obtain the boundary of the application of spread spectrum method.

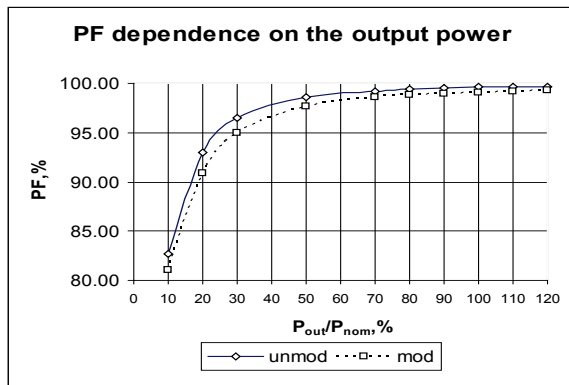

Fig. 4. The dependence of PF on the output power

The simulation data show that, as it was predicted for domination of P_{const} and P_{lin} in Eq(6), the periodic and chaotic modulation does not affect the efficiency and the PF of PFC in the wide range of modulating frequencies and deviation values. All the mentioned results were

obtained for the full load operation of PFC. However this is not the only possible operating regime and nowadays there are steady claims for minimizing the light load power consumption, thus optimizing PQ and η of converters, so it would be necessary to determine the effects of additional modulation on the PF and efficiency in the entire load range.

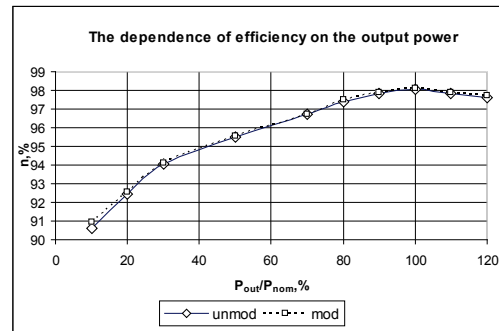

Fig. 5. The dependence of efficiency of PFC on the output power

In order to evaluate the possible effects of the control signal's modulation as the output power is varied, all the mentioned parameters were obtained for $P_{out} = [0.1P_{nom}, \dots, 1.2P_{nom}]$ and $f_m = 2.5\text{kHz}$, $\Delta f_{sw} = 30\text{kHz}$. The appropriated data were represented in the Fig.5.

During simulations it has been noticed that the output power variations does not affect the impact of the control signal's modulation on the parameters under test. So the previous results and conclusions could be related to the operation of the PFC under all possible load variations.

Experimental results

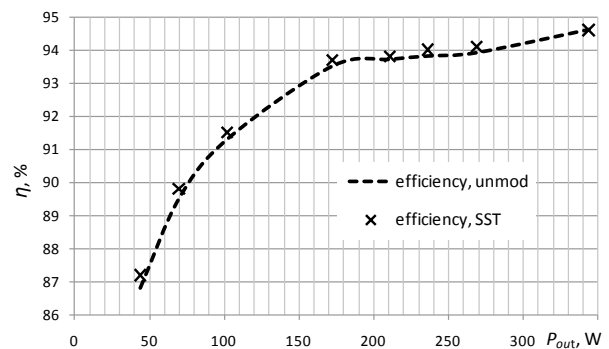

Fig. 6. Efficiency η vs. P_{out} ($f_{sw} = 100\text{kHz}$; $\Delta f_{sw} = 30\text{kHz}$; $f_m = 2.5\text{kHz}$)

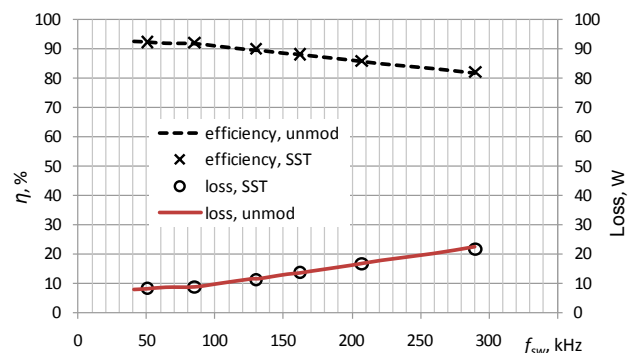

Fig. 7. Efficiency and loss vs. switching frequency ($\Delta f_{sw} = 30\text{kHz}$; $f_m = 2.5\text{kHz}$)

In order to examine effect of SST on η and prove our statement mentioned in theoretical analysis, η is measured for different active output loads of PFC with and without modulation (Fig. 6.). The experimental results confirm simulated ones and our theoretical premises, FM does not worsen η of PFC, but slightly increases it (this is because η is approximately proportional to f_{sw} , according to Fig. 7).

As for THD and PF, FM does not deteriorate them. They are approximately constant in the broad range of Δf_{sw} , and f_m .

Conclusions

This investigation shows that in the case of active PFC it is possible to combine high PQ with low EMI by the use of low-cost method – SST for EMI suppression. Both simulations and experiments are sustaining the theoretical hypothesis stating as long as there is no domination of nonlinear terms in total losses of PFC the use of SST does not worsen the efficiency. This finding allows concluding that SST, providing impressive possibilities of EMI reduction and not affecting other significant power quality parameters (THD, PF), is very useful method for application in active PFC.

References

1. **Corner M.** Tighten power – efficiency regulations // EDN. – 2008. – P. 40–42, 44, 46.
2. **Redl R.** Electromagnetic environmental impact of power electronics equipment // Proc. IEEE. – 2001. – Vol. 89. – No. 6. – P. 926–938.
3. **Mohan N., Undeland T.M., Robbins W.P.** Power Electronics: Converters Applications, and Design. 3rd Ed. – J. Wiley & Sons, 2003. – P. 483–504.
4. **Israelsohn J.** Politically correct power // EDN. – 2005. – P. 40–42,44,46,48.
5. **Kusko Al., Thompson M.T.** Power quality in electrical systems. – McGraw Hill, 2007. – 225 p.
6. **Lin F., Chen D.** Reduction of power supply emission by frequency modulation // IEEE Trans. Power Electronics. – 1994. – Vol. 9. – No.1. – P.132–137.
7. **Balcells J., Gonzales D., Gago J., Satolaria A., Bunetel J. C. L., Magnon D., Brehaut S.** Frequency modulation techniques for EMI reduction in SMPS // in Proc. 9th Europ. Conf. Power Electron. and Applications (EPE'05). – 2005. – P. 1–6.
8. **Choi W-S., Young S-M., Kim D.** A new breakthrough in more efficient power conversion // Bodo's Power Systems, Nov. 2009. – P.46 – 48.
9. **Agrawal J. P.** Power Electronics Systems: Theory and Design. – Prentice-Hall, 2001. – 562 p.
10. **Lin D., Zhou P., Fu W. N., Badics Z., Cendes Z. J.** A dynamic core loss model for soft ferromagnetic and power ferrite materials in transient finite element analysis // IEEE Trans. Magn. – 2004. – Vol. 40. – No. 2. – P. 1318–1321.
11. **Reinert J., Brockmeyer A., de Donker R. W.** Calculation of losses in ferro- and ferrimagnetic materials based on the modified Steinmetz equation // IEEE Trans. Ind. Appl. – 2001. – Vol. 37. – No.4. – P.1055–1061.
12. Aluminium Electrolytic Capacitors. Application Guide // Cornell Dubilier, Liberty, SC. – 2007. – P. 2.183 – 2.202.
13. **Amarel A. M. R., Cordoso A. J. M.** An economic offline technique for estimating equivalent circuit of aluminium electrolytic capacitors // IEEE Trans. Instr. Measur. – 2008. – Vol. 57. – No.12. – P. 2697–2710.
14. **Jankovskis J., Stepins D., Pikulins D.** Lowering of EMI Noise in Boost Type PFC by the use of Spread Spectrum // Electronics and Electrical Engineering. – Kaunas: Technologija, 2009. – No. 6 (94). – P. 15–18.

Received 2010 04 08

J. Jankovskis, D. Stepins, D. Pikulins. Efficiency of PFC Operating in Spread Spectrum Mode for EMI Reduction // Electronics and Electrical Engineering. – Kaunas: Technologija, 2010. – No. 7(103). – P. 13–16.

The investigation deals with the influence of spread spectrum technology (SST) on several of the most important power quality parameters of switch-mode power factor corrector. The analysis covers some significant effects of frequency dependence of power losses, specific for the power components. Computer simulations and experimental results show the most distinguishing dependences of different power quality parameters on SST. The provided data allow to conclude that the implementation of frequency modulation in power factor corrector does not worsen the total harmonic distortion, the efficiency and the power factor in the wide range of modulating frequencies, deviation values and output power variation. Thus SST is one of the most promising methods for EMI reduction in power factor correctors. Ill. 7, bibl. 14 (in English; abstracts in English, Russian and Lithuanian).

Я. Янковский, Д. Степин, Д. Пикюлин. Исследование коэффициента мощности и КПД корректора методом распределенного спектра // Электроника и электротехника. – Каунас: Технология, 2010. – № 7(103). – С. 13–16.

Данное исследование посвящено изучению влияния технологии распределенного спектра (TPC) на некоторые характеристики качества энергии импульсного корректора коэффициента мощности (ККМ). Теоретический анализ позволяет оценить наиболее выраженные зависимости мощности потерь от частоты для компонентов силовой электроники. Результаты симуляций и экспериментов показывают зависимости характеристик ККМ от параметров модулирующего сигнала. Полученные данные позволяют утверждать, что применение частотной модуляции в ККМ не ухудшают КПД и коэффициент мощности в широком диапазоне значений частот и девиаций модулирующего сигнала. Вышеприведенные наблюдения позволяют утверждать, что TPC является одним из лучших методов борьбы с электромагнитными помехами в ККМ. Ил. 7, библи. 14 (на английском языке; рефераты на английском, русском и литовском яз.).

J. Jankovskis, D. Stepins, D. Pikulins. Galios naudingumo koeficiento tyrimas, atliekant spektrinę analizę // Elektronika ir elektrotechnika. – Kaunas: Technologija, 2010. – Nr. 7(103). – P. 13–16.

Aprašoma naujai sukurta technologija, leidžianti įvertinti energijos impulsines charakteristikas bei galios nuostolius. Eksperimentų rezultatai rodo, kad moduliaciniai signalai yra glaudžiai susiję su atrastu galios impulsiniu kokybės parametru. Dažninė moduliacija labai pagerina galios parametrus plačiame dažnių diapazone. Įrodyta, kad ši technologija leidžia sumažinti elektromagnetinius triukšmus, todėl siūloma taikyti ją šiandieninėse elektroninėse sistemose. Il. 7, bibl. 14 (anglų kalba; santraukos anglų, rusų ir lietuvių k.).

DOI: 10.5755/j02.eie.9266