

Thermal Analysis of the Three-Phase Induction Motor and Calculation of Its Power Loss by using Lumped-Circuit Model

Y. Oner

Department of Electrical Education, Technical Education Faculty, Pamukkale University, Kinikli Campus, 20100, Denizli, Turkey, phone: +90 258 296 3322, e-mail: yoner@pau.edu.tr

Introduction

Thermal Lumped-parameter method is the most popular method used in the estimation of the heat increase seen in electrical systems. Thermal model is based on heat resistances, heat capacitances and power losses.

During heat analysis, an electric system is described as geometries including many Lumped components and with the help of linear networks of the heat resistances of each component, neighboring components generate and store heat. In (Fig. 1), heat web of a simple heat system is seen. Lumped parameters are calculated from the size-related information, thermal characteristics of the materials used in the design and constant heat transfer coefficients. Among the stable heat circuit conditions, heat resources are combined at one point among heat resistances and components. For transient analysis, heat thermal capacitances are used by considering the energy exchanges taking place within the body over time.

When the literature is reviewed, it is seen that Boglietti et al., compared 2.2kW and 4kW synchronous reluctance motor with induction motor by carrying out their thermal analyses and they used Motor-Cad thermal analysis program package for this comparison [1]. P.H. Moller et al., developed the Lumped parameters-based thermal model of the induction motors with varying powers and they compared them through experimental results [2]. Z. J. Liu et al., carried out the analysis of fixed magnet brushless direct current motor with Lumped circuit model [3]. W. H. Tang et al., drew out the thermal model of power transformers and carried out thermal analysis with genetic algorithm [4]. D. A. Staton carried out computer-assisted thermal design and analysis of compact motor [5]. Dieter Gerling and Gurakuq Dojaku carried out the design and analysis of Lumped thermal model [6]. Y. K. Chin et al., by using two different commercial analysis program packages (Motor-Cad and FEMLAB), carried out the thermal analysis of permanent magnet synchronous motor through both Lumped circuit model and finite elements method [7].

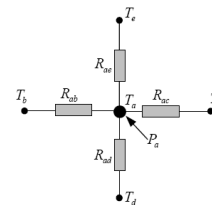

Fig. 1. The basic thermal network constituting the system

In the present study, different from the above mentioned studies in the literature, the purpose is to find the best cooling type and materials by varying the materials used to make the cooling parts of the motor and cooling types within the design process of a three-phase induction motor.

The Effect of Heat on Electrical Machines

In the process of energy conversion taking place in an electrical machine, certain amount energy gets lost in the form of heat. These losses can be called as stable losses occurring without charge and losses depending on charge changing in line with the square of the armature current. Stable losses include iron, friction and wind losses and copper losses resulting from magnetizing current. Charge-dependent losses are primarily those stemming from copper losses. By means of thermal classification of the insulating materials used in the cooling of the machine, it was rendered possible to make the working temperature of the certain parts of the machine stable.

Every insulating material has a certain working temperature complying with the expected life of the machine and allowing the machine to safely function within this expected period. Even a small increase in the temperature can considerably decrease the working life of the insulating material.

Lumped-Circuit Analysis

In the present study, thermal analyses were carried out with MOTOR-CAD program package [8]. This program defines thermal problems by using basic webs

analyses. In this stage, which jacket types and which materials would be used were determined and then thermal analyses were carried out.

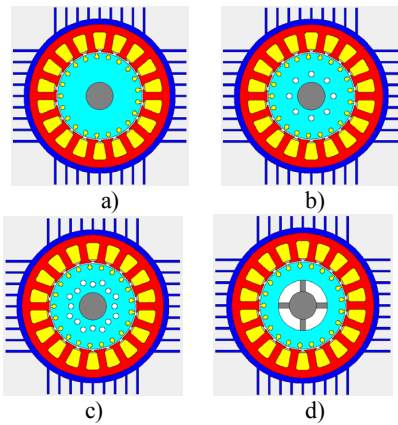

Fig. 4. Different rotor types and different short circuit bars

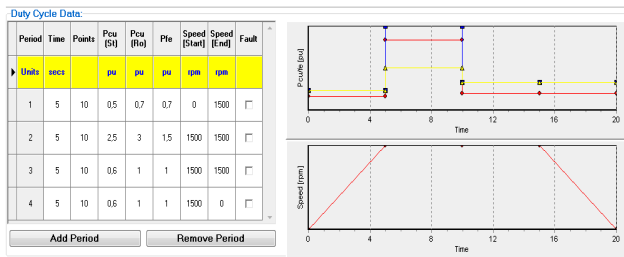

Fig. 5. Speed, acceleration and load values of the motor

Analyses

In this section, thermal performance analyses were conducted by using various insulating materials. The insulating materials and outer jacket to be used have important effects on the heating and cooling of the motor. Considering this fact, analyses were carried out and results obtained.

In order to analyze the thermal performances of the motor, three different types of materials and cooling systems were selected and their analyses were performed. First of them is aluminum material with water cooling canal, the second one is cast-iron body with axial cooling jacket and the third one is teflon material with axial cooling system.

Aluminum material with water cooling

The results of the analyses carried out for aluminum motor jacket and water cooling system are presented in (Fig. 6).

As previously defined, thermal resistance values were automatically calculated based on the sizes and materials-related information. The accuracy of the calculations depends on the information about the resistance of the connections among the parts of the motor.

When the (Fig. 7) is examined, it is seen that the thermal values in the rotor area have reached 112.5 °C. Machine for the different components within the load cycle with 10 iterations in the solution was found and the thermal transient analysis as shown in (Fig. 7).

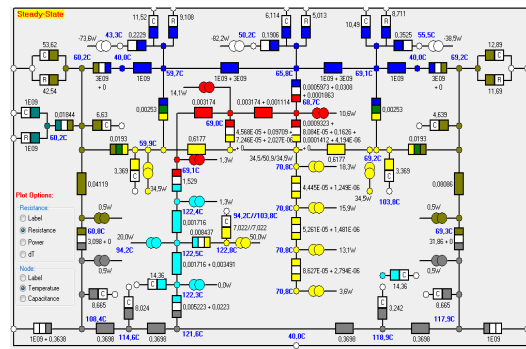

Fig. 6. Steady-state scheme for aluminum

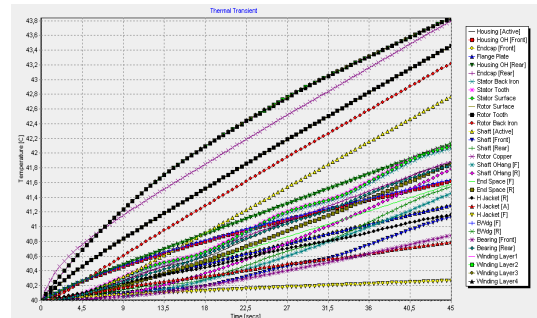

Fig. 7. Thermal values in the different parts of the motor

As can be seen, fins heat and cool faster when compared to the body of the machine. This is the reason why steady-state thermal analysis is needed. It can be noted that heat increase in the rotor part is more remarkable.

Cast-iron body with axial cooling jacket

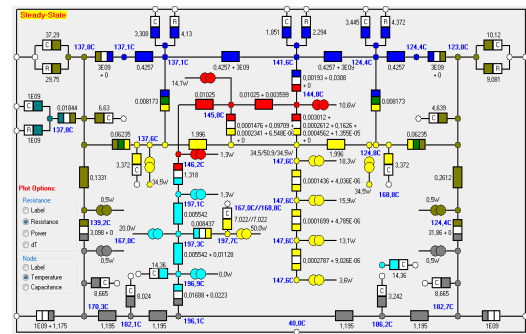

Fig. 8. Steady-state scheme for cast-iron

Here, cast-iron material instead of aluminum was selected for motor jacket. Again, axial system was selected as the cooling system. When this was analyzed under the same iteration, acceleration and speed conditions, the constant state scheme presented in (Fig. 8) was found.

As can be seen, depending on the material used and jacket type, the temperature in the rotor base has reached up to 197. This is because the heat convection of the material used is less than the aluminum material.

Teflon material with axial cooling system

This time, motor jacket was made from teflon material instead of cast-iron. Again, the cooling system

was axial cooling system. When this was analyzed under the same iteration, acceleration and speed conditions, the steady-state scheme presented in (Fig. 9) was found.

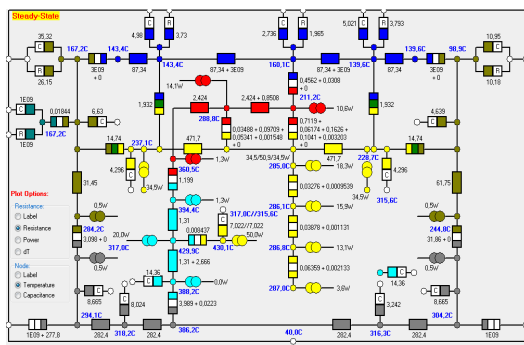

Fig. 9. Steady-state scheme for Teflon material

As can be seen in the analyses of the teflon material and axial cooling system, thermal values in the rotor base have reached up to 430 °C.

Conclusions

In the present study, motor heat distributions obtained at 1500 cy/min by using thermal analysis program package were investigated. In (Fig. 5-7-8), heat changes for the motor are presented. While the motors made from different materials and with different jackets are working, increases seen in the losses can be calculated depending on the increases in the heat. It was already reported that changes in the heat are closely associated with heat convection capacity of the material used. It was found that when teflon material is used, excessive warming is observed on the rotor surface. This is because of the good insulating capacity of the teflon material [9].

As can be seen, while designing an induction motor, not only mechanical and magnetic analyses but also thermal analyses should be carried out. Moreover, while conducting thermal analyses, different materials and cooling systems should be included in analyses and the most suitable ones should be selected.

The present study revealed that the best stator material for an induction motor is aluminum and the best cooling jacket is the cooling with water canals. However, this is not valid for an induction motor with different sizes. For each design, separate analyses should be performed. ...

References

1. **Boglietti A., Cavagnino A., Pastorelli M., Staton D., Vagati D.** Thermal Analysis of Induction and Synchronous Reluctance Motors // IEEE Transactions on Industry Applications. – June, 2006. – Vol. 42. - No. 3. – P. 675-680.
2. **Mellor H., Roberts D., Turner R.** Lumped parameter thermal model for electric machines of TEFC design // IEE Proceedings B Electric Power Applications. – Sep, 1991. – Vol. 138. - No. 5. – P. 205-218.
3. **Liu Z. J., Howe D., Mellor P. H., Jenlins M. K.** Thermal analysis of permanent magnet machines // Sixth International Conference on Electrical Machines and Drives. – Sep, 1993. – P. 359-364.
4. **Tang W. H., Wu Q. H., Richardson Z. J.** A Simplified Transformer Thermal Model Based on Thermal- Electric Analogy // IEEE Transactions on Power Delivery. – July, 2004. – Vol. 19. - No. 3. – P. 1112-1119.
5. **Staton D. A.** Thermal Computer Aided Design Advancing the Revolution in Compact Motors // IEMDC 2001 International Conference on Electrical Machines and Drives. – June, 2001. – P. 858-863.
6. **Dieter G., Gurakuq D.** Novel Lumped Parameter Thermal Model for Electrical Systems // European Conference on Power Electronics and Applications, 2005. - P. 1-10.
7. **Chin Y. K., Nordlund E., Staton D. A.** Thermal Analysis Lumped Circuit Model and Finite Element Analysis // The 6th International Power Engineering Conference. - Singapore, 2003. – P. 27- 29.
8. **Brazaitis A., Guseinovicė, E. Jankūnas V.** Control of Oscillation Amplitude of Oscillating Motors // Electronics and Electrical Engineering. – Kaunas: Technologija, 2010. – No. 3(99). – P. 77–82.
9. **Gokdemir F.** 3 Fazlı Asenkron Motorun Motor-Cad Programı ile Isıl Analizi // Pamukkale Üniversitesi Mühendislik Fakültesi Elektrik-Elektronik Bölümü Bitirme Tezi, 2008. (Turkish).

Received 2010 02 15

Y. Oner. Thermal Analysis of the Three-Phase Induction Motor and Calculation of Its Power Loss by using Lumped-Circuit Model // Electronics and Electrical Engineering. – Kaunas: Technologija, 2010. – No. 8(104). – P. 81–84.

One of the most important factors to be considered in the design of a motor is the thermal structure of the motor. That is, pre-calculation of the thermal temperatures to be experienced by the parts of the motor while working should be performed and hence, appropriate materials should be selected. There are two main approaches to these calculations. These are analytic Lumped circuit model and numerical analysis. The purpose of the present study is to draw out the Lumped circuit model of three -phase induction motor and calculation of the thermal values for its parts by employing Motor cad program package. Ill. 9, bibl. 9 (in English; abstracts in English, Russian and Lithuanian).

И. Онер. Применение модели Лумпеда для анализа работы трехфазных асинхронных двигателей // Электроника и электротехника. – Каунас: Технология, 2010. – № 8(104). – С. 81–84.

Исследуется температурное влияние на параметры двигателей с учетом свойств материалов и температурных режимов отдельных частей. Расчет двигателя осуществлен методом Лумпеда и дискретным методом. Для температурного режима применен пакет программ типа Motor cad. Ил. 9, библи. 9 (на английском языке; рефераты на английском, русском и литовском яз.).

Y. Oner. Lumpedo grandinės modelio taikymas trifaziame asinchroniniame variklyje ir jo temperatūrinė analizė // Elektronika ir elektrotechnika. – Kaunas: Technologija, 2010. – Nr. 8(104). – P. 81–84.

Vienas iš pagrindinių veiksnių, į kurį turi būti atsižvelgta projektuojant elektros variklį, yra variklio šiluminės savybės. Iš anksto būtina apskaičiuoti atskirų variklio dalių kuriamas temperatūras bei parinkti atitinkamų savybių medžiagas. Skiriami du pagrindiniai skaičiavimo būdai: analitinis Lumpedo grandinės modelis ir skaitmeninė analizė. Apžvelgtas Lumpedo grandinės modelis ir, taikant Motor cad programą paketą, atlikti trifazio asinchroninio variklio temperatūrų skaičiavimai. Il. 9, bibl. 9 (anglų kalba; santraukos anglų, rusų ir lietuvių k.).

DOI: 10.5755/j02.eie.9233