

Innovative Method of Flow Profile Formation for Ultrasonic Flowmeters

P. Borodičas

*Mechatronics Centre for Research, Studies and Information, Kaunas University of Technology,
Kestucio str. 27, LT-44025 Kaunas, Lithuania, e-mail: paulius.borodicas@stud.ktu.lt*

A. Ragauskas, V. Petkus

*Telematics Scientific Laboratory, Kaunas University of Technology,
Studentu str. 50-448, LT-51368 Kaunas, Lithuania, e-mail: telematics@ktu.lt*

A. Bagdonas

*Department of Innovation, AB Axis Industries,
Kulautuvos str. 45A, LT-47190 Kaunas, Lithuania, e-mail: arnoldas.bagdonas@axis.lt*

R. Šlīteris

*Ultrasound Institute, Kaunas University of Technology,
Studentu str. 50, LT-51368 Kaunas, Lithuania, e-mail: reimondas.slīteris@ktu.lt*

Introduction

The temperature changes of the flowing liquid make an essential influence on measurement errors for ultrasonic flow and heat measuring devices based on the time-of-flight measurement principle. The reason for this is the temperature dependence of physical properties of liquids (such as ultrasound velocity, viscosity), as well as electrical impedance of ultrasonic transducers [1]. In order to solve this problem, typically additional functions of temperature measurement and the correction of temperature-dependent hydrodynamic errors are included into the flow measurement devices. Other methods are based on the formation of liquid velocity profile inside the measurement channel and the ultrasonic pulse transmission close to the region of velocity profile where normalized velocity is less dependent on the changes between the flow regimes (laminar and turbulent) [2–6]:

- methods based on the formation of velocity profile in measurement channels with the rectangular or hexagonal cross-section and the transmission of the ultrasonic pulse into the spiral acoustic path along the channel [3–5],

- methods based on the formation of velocity profile in a round-shape measurement channel with a special flow profile correcting equipment inserted into the channel [6].

In the authors' earlier works the ultrasonic flowmeter with the triangular cross-section measurement channel was presented [2, 7–10]. The main distinctive peculiarity of this flowmeter is that there it is possible to arrange the ultrasound beam path closer to the crossing line of laminar and turbulent flow profiles (Fig. 1a) and, as a result, it is

possible to achieve a much wider dynamic range and a better accuracy of such ultrasonic flow meter.

These properties of the measurement duct with a triangular cross-section can be adapted in order to get the maximal coincidence of the acoustic path of the transmitted ultrasonic wave along the measurement channel with the profile region where the normalized velocity remains the same in the laminar and turbulent flow regime. The location of this velocity region in the duct with a triangular cross-section is shown in Fig. 1.

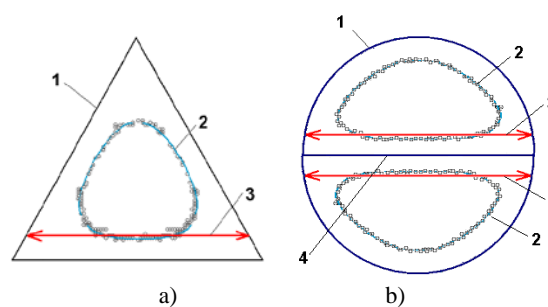

Fig. 1. Positioning of the acoustic paths of the ultrasonic signal within the measurement channels having a triangular cross-section (a) and circular cross-section (b). 1 is the cross-section of measurement channels, 2 is the region of the normalized velocity profile, where laminar and turbulent regimes crosses, 3 is the acoustic path, 4 is the dividing plate

The optimal way to get the coincidence of the acoustic path with this region is to transmit the ultrasonic wave along the channel close to one of the walls of the

triangular duct. Because such method may be sensitive to the non-symmetric flow profile, there is a suggestion to put close together two ducts with a triangular cross-section by forming a quadrangle duct split symmetrically into two triangular ducts or the formation of the two adjacent ducts with a semicircle cross-section.

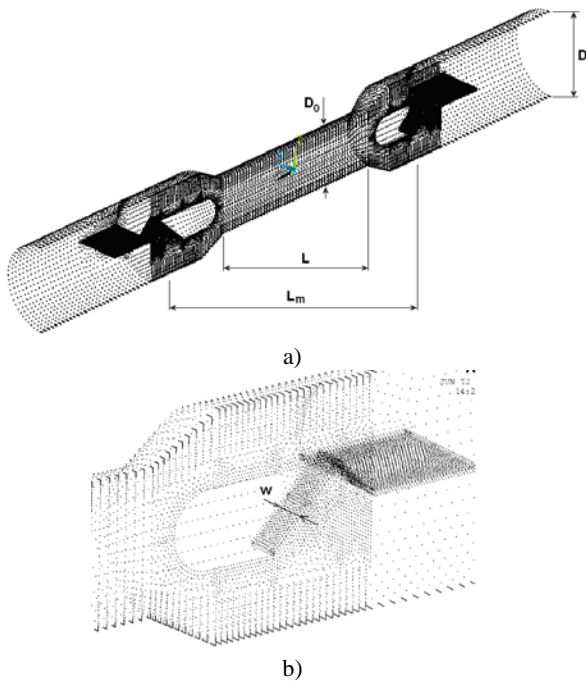

Fig. 2. The finite element model of the flow sensor DN 50 with the inserted plate into the measurement channel (longitudinal cross-section): 245166 nodes; 636095 elements. The nodes of finite element model are shown, which represents the limiting edge conditions (where the normal velocity is zero)

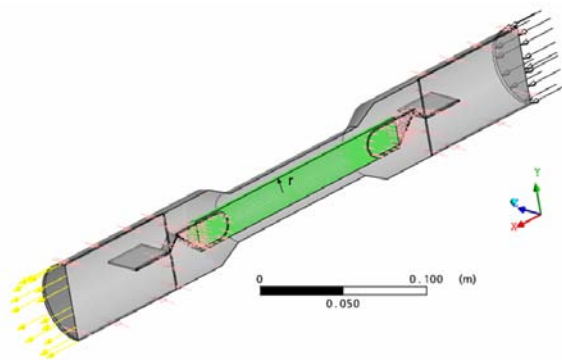

Fig. 3. The cylindrical volume with the radius r , where the averaged velocity is calculated (longitudinal cross-section). This velocity value corresponds to the integral velocity measured by transmitting ultrasonic wave between two ultrasonic transducers

Methods and equipment

The computer modelling of a flow profile inside the round tube with the inserted longitudinal dividing plate has been performed in order to determine a hydrodynamic correction factor of the flow sensor and other peculiarities of this flow measurement equipment. The finite element modelling method has been chosen and fluid flow simulation within DN50 size flow sensor has been performed. Geometrical dimensions of DN50 size flow sensor were used for calculations: $D = 50$ mm - diameter at

the inlet and outlet of the flow sensor, $D_0 = 32$ mm - diameter of the inner measurement channel, $L = 130$ mm - distance of the inner measurement channel, $w = 7$ mm - width (radius) of mirrors at inlet and outlet, $L_m = 180$ mm - distance between the centres of mirrors (Fig. 2).

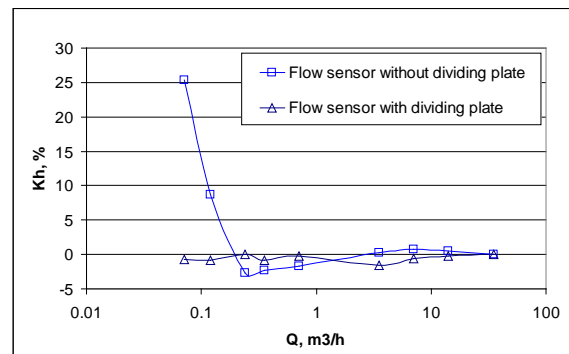

Fig. 4. The calculation of hydrodynamic correction factors after the flow simulation in the flow sensor of size DN 50 within a flow range 0,06 ... 30 m³/h.

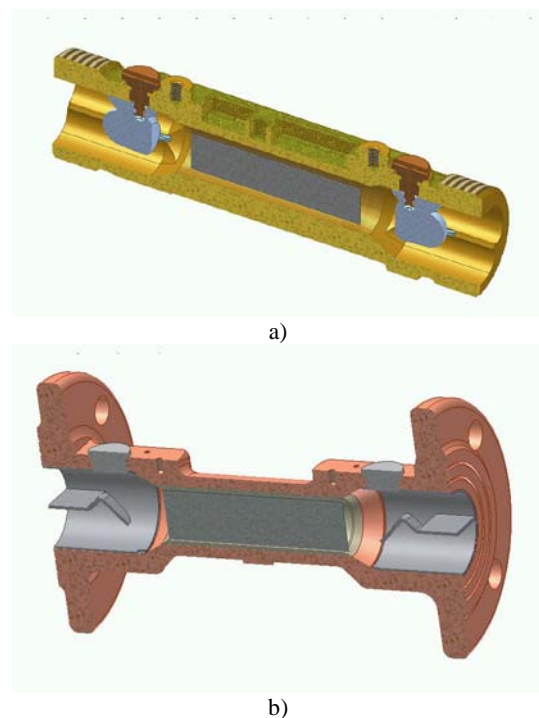

Fig. 5. The longitudinal cross-section of SDU 1L flow sensors (manufacturer AB Axis Industries, Lithuania) used for experimental investigation: flow sensor of size DN20 (a) and DN50 (b). The plate inserted into the measurement channel divides the cylindrical channel into two semicircular cylinders

The measurement channel was divided into two semicircular channels from one mirror at the inlet to the other mirror at the outlet. For estimation of the hydrodynamic correction factor, the fluid velocity has been integrated within the semicircular cylinders between both mirrors. The radius of the cylinders was chosen $r = 6$ mm, respectively to the real diameter of ultrasonic transducers $d = 12$ mm. The volume of both semicircular cylinders, where integral velocity was calculated, is located at both sides of the longitudinal dividing plate (Fig. 2 and 3). The calculation of hydrodynamic correction factors were performed for the cases when the longitudinal dividing

plate was inserted in the measurement channel and when the measurement channel was without a dividing plate (Fig. 4). These results show, that by inserting a plate into the circular measurement channel, the slope of the hydrodynamic correction function decreases from 25 % (for the channel without a plate) to 3% (for the channel with a plate) within the dynamic flow measurement range of 500. This means that by using a dividing plate inserted along the measurement channel it is possible to expand the dynamic measurement range and to obtain an almost flat calibration function with a slope $\sim 3\%$.

Results

The experimental investigation of the effect of the insertion of the dividing plate into measurement channels was performed with flow sensors SDU1L (manufacturer AB Axis Industries, Lithuania) having the sizes DN20 (permanent flow rate $q_p=2,5 \text{ m}^3/\text{h}$) and DN50 (permanent flow rate $q_p=15,0 \text{ m}^3/\text{h}$) (Fig. 5). During the investigation it was determined how the dividing plate influences the amplitude of the received ultrasonic signal after its propagation through the measurement channel (Fig.6) and the hydrodynamic correction factors (Fig. 7).

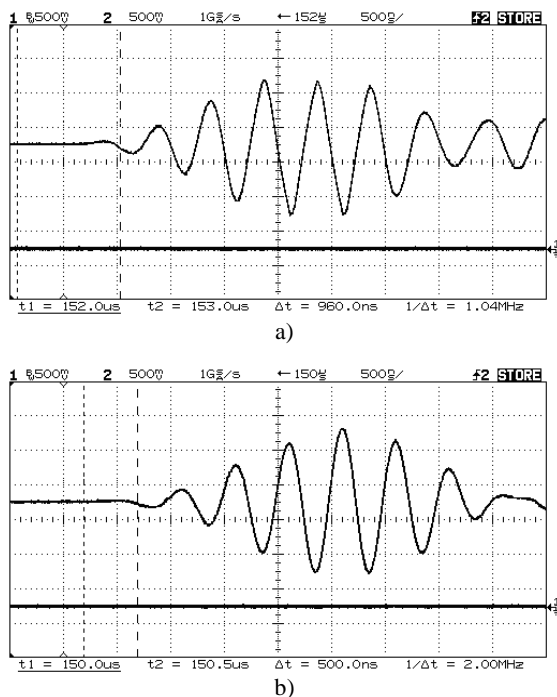

Fig. 6. The demonstration of negligible influence of a dividing plate after its insertion into the measurement channel of the flow sensor DN50 on the waveform of the received ultrasonic signal: the signal after its propagation through the measurement channel without plate (a) and with the inserted dividing plate (b)

The plate inserted into the measurement channel divides the flow and the ultrasound wave into two semicircular segments of the cylinder. Fig. 6 shows that such division of the ultrasound wave does not affect the waveform and the amplitude of the received ultrasonic signal after its propagation through the measurement channel. Fig. 7 also shows that such insertion of the plate also affects the flattening of the hydrodynamic correction function. After the insertion of the dividing plate into

measurement channel, the slope of the hydrodynamic correction function decreases from 15 % (for the case without a dividing plate) till 5 % (with a dividing plate).

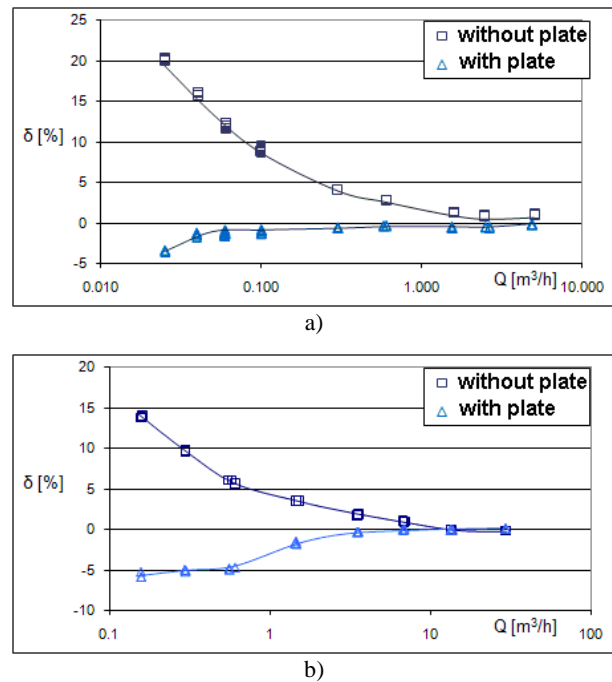

Fig. 7. The hydrodynamic correction functions measured for the flow sensors of size DN20 (a) and size DN50 (b). The square points show the calibration function obtained without using a dividing plate, triangle points show the calibration function obtained after the insertion of a plate into measurement channels

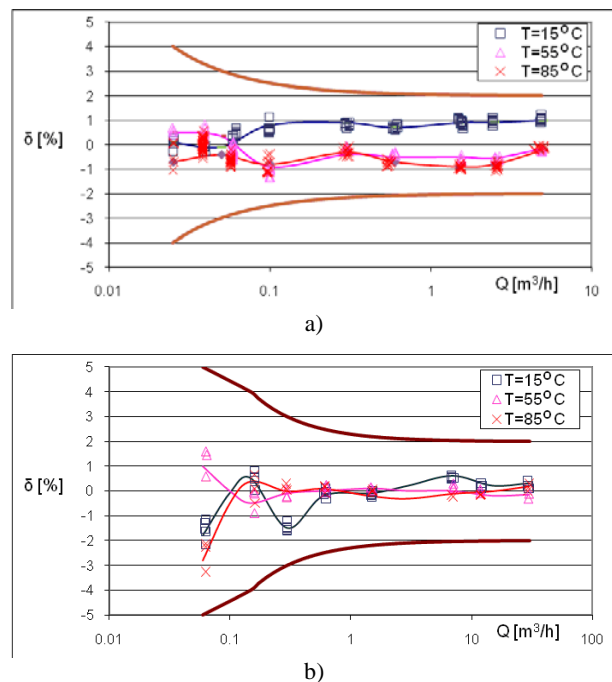

Fig. 8. The flow measurement errors obtained for flow sensors of size DN20 (a) and DN50 (b) at water temperatures 15°C , 55°C and 85°C . The flow sensors were with the plates inserted into the measurement channels and no temperature correction was used. A solid line represents limits of admissible flow errors according to EN1434 for accuracy class 2 of flow sensor. The flow errors were measured within a typical range $0,025 \dots 5,0 \text{ m}^3/\text{h}$ for the flow sensor of size DN20 and within the expanded range $0,06 \dots 30,0 \text{ m}^3/\text{h}$ for a flow sensor of size DN50

The experimentally measured errors of the flow sensors DN20 and DN50 with the inserted dividing plate are shown in Fig. 8. The measurements were performed at water temperatures 15°C, 55°C and 85°C without using any temperature correction in the flow sensors. These results indicate that by using a dividing plate inserted into the measurement channels it is possible to reduce the slope of the flowmeter calibration function, and also to avoid the necessity of using the unwanted temperature correction.

Conclusions

It is shown that by inserting a dividing plate into the measurement channel of typical ultrasonic time-of-flight flowmeters it is possible to improve their performance:

1) The slope of hydrodynamic calibration function is reduced by 3...5 times depending on the flow sensor size (from 15...20 % to 4...5%).

2) The flattening of the hydrodynamic calibration function gives the possibility to expand the dynamic measurement range up to 2 times.

3) It is possible to achieve acceptable flow measurement errors within a wider temperature range without using the function of temperature correction of hydrodynamic factors.

All these improvements of technical parameters of ultrasonic flowmeters can be achieved by using a cost-effective procedure of mechanical insertion and fixing of a thin stainless steel plate into the measurement channel of the existing flowmeters. The physical reason of these improvements is the usage of a cost-effective method which provides the possibility to transform the flow profile and to perform the ultrasonic scanning within the flow profile region which is less dependent on the changes between the laminar and turbulent flow regimes.

References

1. **Spicer D. W., Boyes W.** Consumer guide to ultrasonic and correlation flowmeter. – USA: Copperhill and Pointer Inc., 2004. – P. 59–68.
2. **Bagdonas A., Daubaris G., Petkus V., Ragauskas A.** Triangular cross section duct for ultrasonic flow rate measurement // *Ultragarsas*. – Kaunas: Technologija, 2005. – No. 4(57). – P. 7–10.
3. **Vontz T.** Device for ultrasonic flow measurement. Patent No. US5650572. 1997–07–22.
4. **Polinski E.** Anordnung zur Messung der Fließgeschwindigkeit eines Mediums. Patent No. EP1255094. 2002 05 02.
5. **Grepmaier P.** Ultraschall–Durchflussmessanordnung. Patent No. EP0715155. 1994 12 02.
6. **Jensen H. E. K., Abildgaard N., Nielsen H.** Ultrasonic metering apparatus. Patent No US4545259. 1983 10 03.
7. **Ragauskas A., Daubaris G., Petkus V.** Ultrasonic flowmeter with triangular cross–section. Patent No. EP1742024 2007.
8. **Ragauskas A., Petkus V., Bagdonas A.** Experimental evaluation of ultrasonic flowmeter with a triangular cross section duct. // *Matavimai*. – Kaunas: Technologija, 2006. – No. 2(38). – P. 16–20.
9. **Ragauskas A., Daubaris G., Petkus V., Raišutis R., Chomskis R., Šlitteris R., Deksnys V., Guzaitis J., Lengvinas G., Rugaitis A.** Non–invasive technology for monitoring of cerebrovascular autoregulation // *Electronics and Electrical Engineering*. – Kaunas: Technologija, 2008. – No. 5(85). – P. 93–96.
10. **Ragauskas A., Daubaris G., Petkus V., Raišutis R., Chomskis R., Šlitteris R., Deksnys V., Guzaitis J., Lengvinas G., Rugaitis A.** Non–invasive technology for monitoring of intracranial volumetric pulse waves and trends // *Electronics and Electrical Engineering*. – Kaunas: Technologija, 2008. – No. 6(86). – P. 51–54.

Received 2010 10 30

P. Borodičas, A. Ragauskas, V. Petkus, A. Bagdonas, R. Šlitteris. Innovative Method of Flow Profile Formation for Ultrasonic Flowmeters // *Electronics and Electrical Engineering*. – Kaunas: Technologija, 2010. – No. 10(106). – P. 91–94.

The ultrasonic flow sensor with minimized temperature-dependent hydrodynamic flow measurement errors is presented. The experimental investigation of ultrasonic flowmeter SDU-1L (manufacturer AB “Axis Industries”, Lithuania) with the flow sensor size DN20 and DN50 has been performed. The results of the investigation show that by inserting a flow profile forming equipment into a flow sensor measurement channel it is possible to minimize the slope of the temperature-dependent hydrodynamic correction factor more than 3 times. Such method of error minimization allows us to avoid the necessity to apply temperature corrections of hydrodynamic factors as well as to expand dynamic measurement range. *Ill. 8, bibl. 10 (in English; abstracts in English and Lithuanian).*

P. Borodičas, A. Ragauskas, V. Petkus, A. Bagdonas, R. Šlitteris. Ultragarsinis srauto matuoklis su srauto profilio formavimo įtaisais // *Elektronika ir elektrotechnika*. – Kaunas: Technologija, 2010. – Nr. 10(106). – P. 91–94.

Darbe pristatytas ultragarsinis srauto matuoklis su minimizuotomis nuo temperatūros priklausomomis hidrodinaminėmis matavimo paklaidomis. Eksperimentiniams tyrimams naudoti ultragarsiniai srauto matuokliai SDU-1L (gamintojas AB „Axis Industries“, Lietuva) su srauto jutikliais, kurių sąlyginis skersmuo DN20 ir DN50. Tyrimų rezultatai rodo, kad, įstačius srauto formavimo plokštelę išilgai srauto jutiklio matavimo kanalo, galima minimizuoti nuo temperatūros priklausomo hidrodinaminės korekcijos kreivės nuožulnumą daugiau nei tris kartus. Tokia priemonė leidžia nenaudoti temperatūrinių korekcijų srauto matuokliuose ir išplėsti jų matavimo dinaminį diapazoną. *Il. 8, bibl. 10 (anglų kalba; santraukos anglų ir lietuvių k.).*