

Flexible Product Drying System Design and Application

C. Aküner

Electrical Education Department, Technical Education Faculty, Marmara University, Göztepe/Kadıköy/Istanbul, phone: +90 216 336 57 70, e-mail: akuner@marmara.edu.tr

M. T. Tuncay

Gaziosmanpaşa Üniversitesi, Tokat Meslek Yüksek Okulu, Elektrik-Elektronik Programı, Tokat, e-mail: tanertuncay@gop.edu.tr

Introduction

Drying in plants has been used since antique ages. As a result of drying process, the plants can be stored safely for a long time.

Nowadays, the control methods, which are able to be used in many areas, are also found a wide application area in agricultural areas. One of these areas is the plant drying technology. Dried agricultural products are demanded in certain quality standards in various sectors. Dryer machines are used for this purpose. Drying process of the product in order to make at the desired level and quality, it is necessary supervising the dryer machines the best and the most economical way.

Many control methods are widely used meet this goal. However, PID controllers are used for controlling dryer to fulfill these requirements optimally. The most important reason for choosing PID control to adjust the flexibility, simplicity, can be applied easily to all aspects of the process for this purpose is the most appropriate choice.

In order to provide the highest quality products with the least energy consumption dryers of agricultural products should be controlled with the appropriate methods. The two most important variables controlled in the dryer were the drying air temperature and velocity.

All of these variables are required kept constant in the desired optimum value to obtain quality products in the desired profile during the drying process, reducing energy consumption and for the highest levels of capacity utilization is important.

The quality of products will improve the market share. For this purpose, control of the developed and produced dryer was transferred to the computer with the Labview control program was carried out. The developed system will be established with the highest quality program for different products can be investigated. Also energy savings are realized with the obtained program.

2. Drying System Products

In this study, For Virtual Instruments Engineering Workbench (LABVIEW) laboratory is used as the control program. LABVIEW data collection, control, analysis and presentation of very large data base are used, that provides a reliable, very flexible, powerful graphical programming and simulation environment. Rotary drum dryers are used in practice are depicted in Fig. 1.



Fig. 1. General profile of a rotary drum dryer

Drum dryers specifications are given below: 2 mm diameter hole in the dryer drum with 1 mm thick chrome-nickel stainless steel sheet, 95 cm in diameter, is made 130 cm in length. To facilitate for mixing into the drum as Figure 2, four wings are designed in 20 cm wide, 130 cm length. One side of the drum is closed the other side is closed 70 cm in diameter by made of hard Polyamide material tap in order to provide loading and unloading products, as shown in Fig. 2. Drum was placed on the horizontal way on the four wheel pneumatic tire roller and driven by one of them. Drive wheel is designed providing rotate the drum at the desired speed.



Fig. 2. Wings in the drum



Fig. 3. Rotary drum dryer profile

Heater fan is located at the other end of the air channel opened to the air distribution room. General view of the fan / heater is given in Fig. 4.



Fig. 4. Fan / heater used in the rotary drum dryer

System air flow is adjusted between 0-750 m³ / h both to pass the hot air inside the product to provide necessary static pressure and install fan speed the advanced stages of drying, so it provides energy savings by reducing consumption of the heated air. For this purpose, motor speed control device to set fan speed to the 0-1400 rpm range is used.

Thyristor modules were used in the control of the heaters. Thyristor modules have been used safely such as heating, melting precise temperature control in proportional control applications. Thyristor power control units began to be used often and successfully for industrial type furnaces, glass production, plastic injection molding and press applications, the chemical industry, automotive paint applications, IR printing machines, packaging industry, steel production, cement industry, food production, PET bottle production.

Thyristor power control units in accordance with other control systems more reliable, less lock up, maintain and control the system easily constituted. Potentiometer is fully compatible to automation, in order to control with PLC, PIC, computer and such as automation equipment, they were designed to be able to control with 0-10 V, 0-20 mA, 4-20 mA.

Analog output of the temperature control unit is entered as a set value to thyristor power control unit. Power control unit adjusts the output according to the input. Output of this unit is applied to the heater and it is obtained more sensitive temperature profile than power-relay switch on-off control.

At the beginning of drying out moisture content is higher. Therefore will need to be more heated. As the product is drying out, output of the humidity decreases and the need for heating is reduced.

In this case, in order to reduce used energy to reduce the fan speed to ensure the waste of energy and therefore energy savings have been made. If the moisture output from the dried product value is between 80 -100, the fan speed is the maximum. If output value of humidity is between 0-40, fan speed value is 40%. Fig. 5 shows the block diagram program of the system.

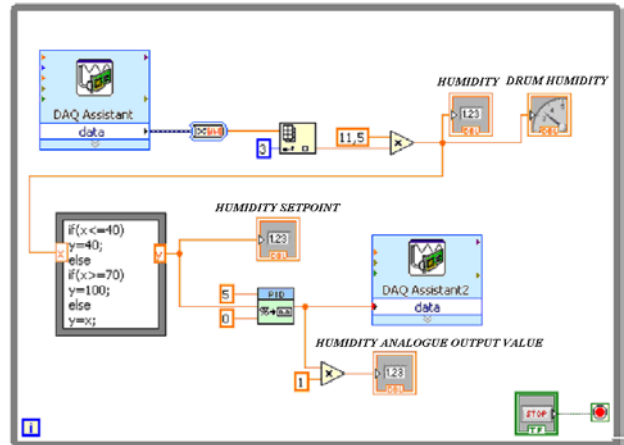

Fig. 5. Block diagram of the control program of fan speed

While performing drying process, different products to be dried have been considered. For this purpose four different drying profiles have been established. In addition to selected four programs from program choice menu for adjust the PID values the PID Set Panel option have been added. This situation is seen in Fig. 6.

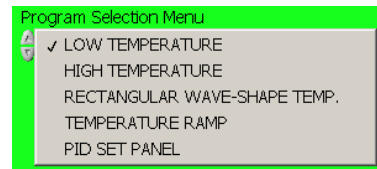

Fig. 6. Program Selection Table

The present programs in the program selection table:

a) Low Temperature: Products are targeted to low-temperature drying application. As temperature 30-35 degrees centigrade are used. In this process without any damage to sensitive products and is expected to be installed without losing their properties. Drying time is longer than the other applications.

b) High Temperature: In this profile it is expected to dry product more quickly. Used temperature around 50-55 degrees centigrade is chosen as a constant.

The basic logic in low and high temperature profiles drying process to be completed at constant temperature. Operator could change the temperature values. Flexibility is provided by opening the control to the operator control. In both profiles temperature control to be made in front of the fan, during drying out excess moisture, especially at first, the drum will be drastically reduced in temperature

and drying time will increase. Fig. 7 LabWiev regarding this situation is seen as the flow chart.

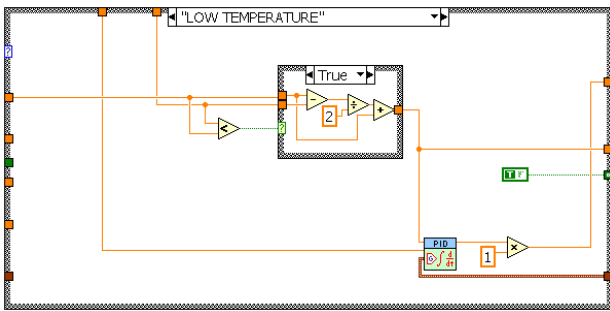

Fig. 7. the flow chart with low-temperature profile

c) Stepping Heat: The goal at this temperature profile to obtain a square wave shape temperature profile by using from the outside to input one of the two-time is low; the other is a high temperature. In this application, targeted products are heated at high temperature for 15 minutes, leaving the low-temperature for 45 minutes to remove the moisture is being thrown out at high temperature from the system. The block of the program as it prepared for this profile is given in Fig. 8.

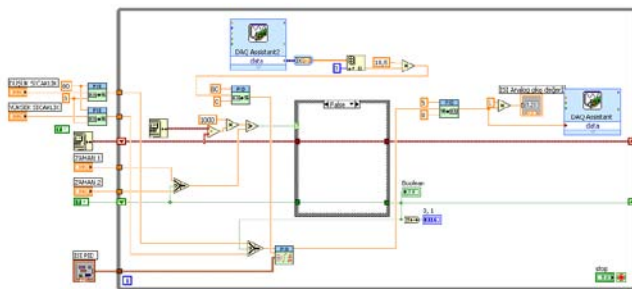

Fig. 8. Program block of Stepping Heat

d) Heat Ramp: This section is established in the needs of the dried material low temperature value was started 5-6 hours a period of linear growth by ensuring a high temperature is reached and the drying process until you have completed at this temperature. Related time and temperature interface are shown in Fig. 9.

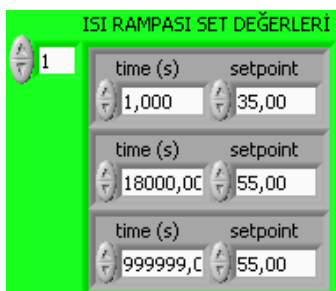

Fig. 9. Time and temperature input interface

The prepared program; block diagram and front panel are made up of two main sections. The block diagram constitutes the inner side of the program. In this section, that contains input, output section the required procedures is performed. The block diagram related for this section is shown in Fig. 10.

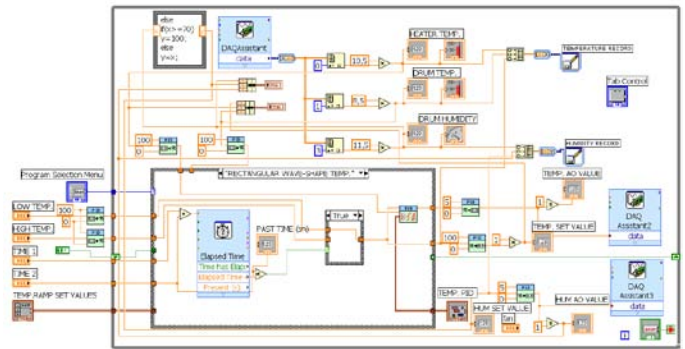

Fig. 10. Block diagram of the program

Front panel supplies operator communication with the machine. Execute program on the system and numerical inputs are entered to the front panel. Moreover, the outputs on desired format are followed from the front panel. Control section of the program was created from three different sections. The first part of the program set values in Fig. 11.

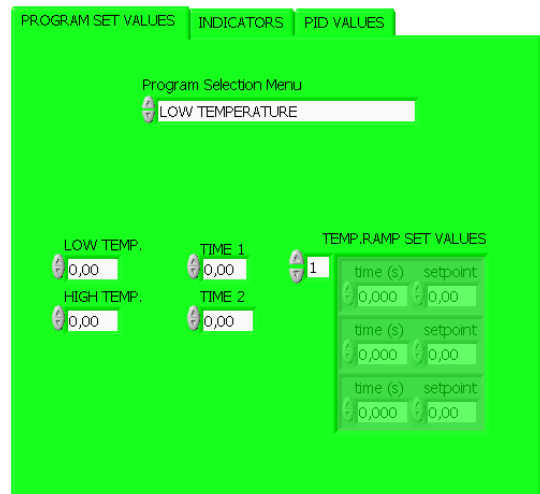

Fig. 11. Input Page of Program Set Values

Program indicators are present in the second part the data have been taken from the machine can be followed. Here, as well as numerical values and visually can be followed. The front panel related to this situation is given in Fig. 12.

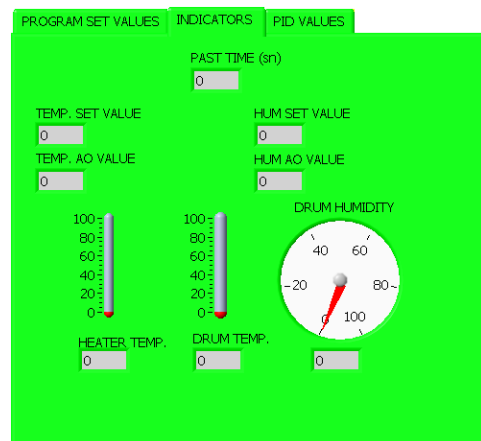

Fig. 12. Front Panel Display Page

Moreover, in order to track graphically for heat and humidity values of the system the graphic interface is used. This situation is seen in Fig. 13.

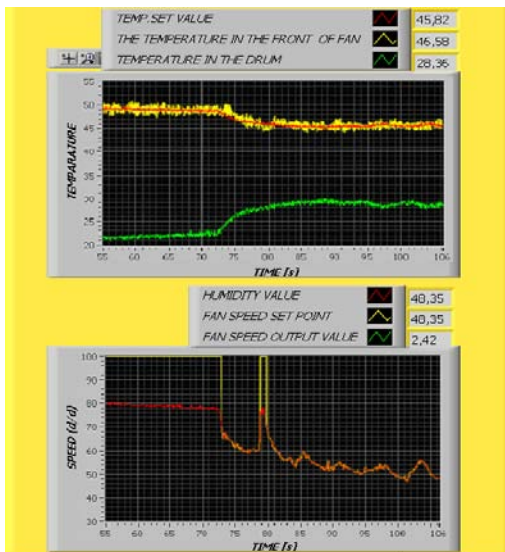

Fig. 13. Observation Charts for Heat and Humidity Values

Application Results

Low-temperature profile is selected by setting value 300 degrees centigrade. The system has been run by following in front of fan temperature and the inside drum temperature. Heat is adjusted based on by using control in front of the fan temperature. If the values of drum temperature lower than the set value, half of the value the difference between the two sets was increased by adding to the set value.

Thus faster and safe dry is provided. As product will not exceed the set heat value product will not get damage. In front of the fan temperature [T (F)], the drum interior temperature [T (T)], the obtained processed set point [T (JOBS)] and set value [T (S)] and plotted graphs is given in below Fig. 14.

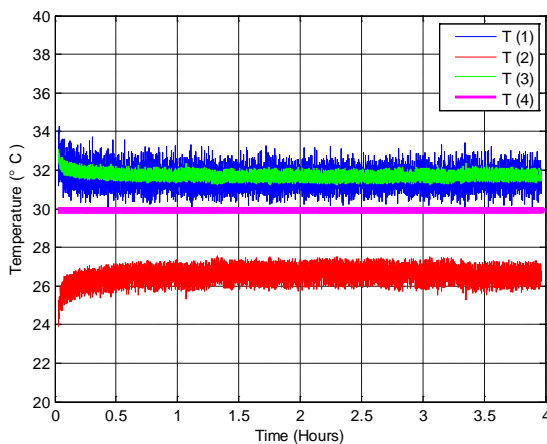

Fig. 14. Temperature-time graph of low temperature profile

The selected temperature to the high temperature profile is 500 degrees centigrade. This temperature value is selected to dry quickly without damage for products. Taste and smell of the plants which differ in temperature for each

plant essential oils are removed from the product and product quality is impaired. Spoilages during drying in plants are due to excess heat and mechanical damage. For this reason, it is important to select the appropriate temperature value to the product characteristics.

Therefore characteristics of the drying product will be well known, or if such as data is absent, before drying product, a small amount samples are dried, the values of the heat how it affects to the products should be investigated.

In this profile, as in the low temperature processed set value has been obtained by adding with the set value and half of the value of internal temperature of the drum. Temperature in front of the fan [T (F)], interior temperature of the drum [T (T)], the obtained processed set point [T (JOB)] and set value [T (S)] and plotted graphs with set value, is given in Fig. 15.

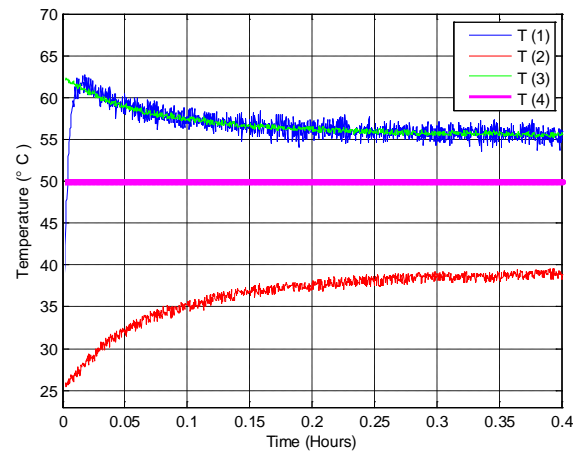

Fig. 15. High temperature profile of initial heat profile

Processed at high temperature profile a set value has not used by running the system as dependent on to the directly set value the graph has been obtained in Figure16. In the graphic temperature in front of the fan is [T (F)], the temperature of inside the drum is [T (T)] and set value [T (S)] is given. As seen from the chart in front of fans around the set point temperature is 500 degrees centigrade. Meanwhile, in a drum temperature of about 33-340 degrees centigrade and processed using the set value 6-70 degrees centigrade is low compared to using temperature profile.

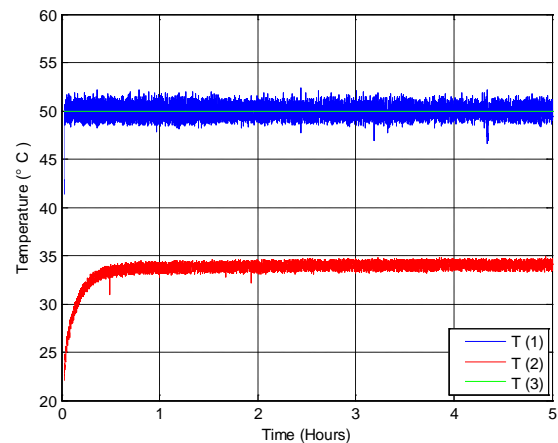

Fig. 16. Set Value at High Temperature Profile Held Constant

Applications made up to here 60% fan speed is used. To examine the effect of fan speed to the temperature value, high temperature profile has been running at 100% fan speed. The data were taken at Fig. 17. While fan speed on 60%, although the drum temperatures about 400 degrees centigrade fan speed up to 100% drum temperature rose to approximately 440 degrees centigrade. Meanwhile, the set point and temperature in front of the fan has decreased from 550 degrees centigrade to 530 degrees centigrade.

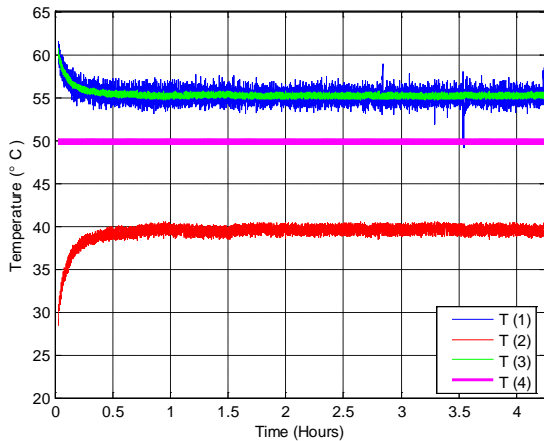

Fig. 17. High-Temperature Profile at 100% Fan Speed

Gradual temperature profile starting with lower temperatures after to run out for 45 minutes reaching to the high temperature the heating has done for 15 minutes. Then return to low heat value again, the application will continue performs a square wave until the drying process reach to the end.

During drying process consistently high temperature are damaging some of the products. Gradual drying profile is an application that will be provided faster drying. The moisture run out of from the products at high temperature is removed from the system in low-temperature values. While products are effected with less damage also energy save will be provided. The obtained results from application are also given in Fig.18. In front of the fan temperature [T (F)], inside the drum temperature [T (T)] and set value [T (S)] are shown on the graphic.

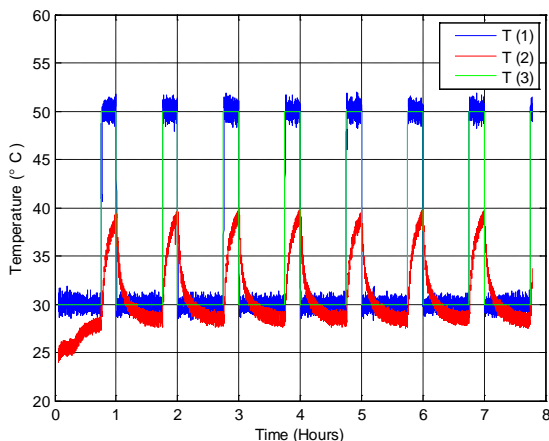

Fig. 18. Gradual temperature profiles

45-minute of an hour period set value low temperature and 300 degrees centigrade for 15 minutes with a high temperature is 500 degrees centigrade. In this way, the square waves are performed. The temperature in front of the fan was followed by the set value. Temperature inside of the drum; while set the value is 500 degrees centigrade, the value increased up to 39-400 degrees centigrade. Set point falls 300 degrees centigrade was approximately 28-290 degrees centigrade. In the temperature ramp profile as soon as the system set to the value of the low temperature reached 5 hour increase is linear. As a result of the profile implementation obtained values are provided in Fig. 19. In front of the fan temperature [T (F)], the temperature inside the drum [T (T)] and set value [T (S)] are shown in the graphic.

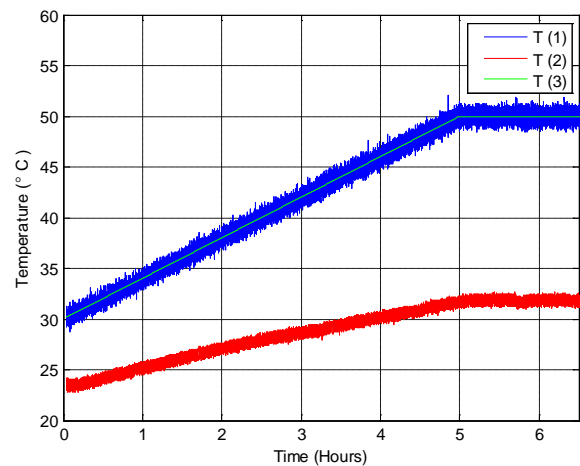

Fig. 19. Profile of Temperature Ramp

In practice as soon as possible to 300 degrees centigrade temperature set point in front of the fan as well as the increase was linear for 5 hours. At the end of 5 hours reached 500 degrees centigrade has remained constant. The inside of the drum temperature, rose from 230 degrees centigrade to 320 degrees centigrade, and this value is fixed.

Conclusions

If agricultural products are not dried suitable conditions, such as mold, discoloration, odor and taste disturbance unintended consequences occurs,

In this study a wide range of products with different profiles, the most economical and to see least harmful way the establishment of commercial size dryer developed. Dryers can provide all types of products suitable for drying. Different products can be dried by making appropriate changes at operator panel.

Carried out with the drying system for required every type agricultural products dryer can be obtained. Different production capacity needs can meet by changing the physical size of the drying system.

Acknowledgements

This application is supported by TUBITAK under the project number:107-O-101 producing on rotary drum dryer

was carried out. Thanks to Associate professor Dr.Sefa Tarhan who helped us in this study for planning a dryer.

References

1. **Tahran S., Telci İ., Tuncay M. T.** Tıbbi ve Aromatik Bitkileri Kurutma İşleminde Yüksek Kaliteli Ürün ve Enerji Tasarrufu Elde Etmek Amacıyla Yeni Kurutucu Prototiplerinin Geliştirilmesi ve Performanslarının Belirlenmesi. – Tübitak 107-O-101 nolu proje raporu, (2009).
2. **Tuncay M. T., Tahran S., Akuner C., Korucu, B.,** Tarımsal Ürün Kurutucularında Kontrol Mühendisliği Uygulamaları // Uluslar arası. – Ulusal Meslek Yüksek Okulları Sempozyumu. – Konya, Türkiye, Mayıs, 2009. – P. 3053–3062.
3. **Halvorsen B. L., et al.** A Systematic Screening of Total Antioxidants in Dietary Plants // J. Nutr, 2002. – Vol. 132. – P. 461–471.
4. **Yanishlieva N. V., Marinova E., Pokorny J.** Natural Antioksidants From Herbs and Spices // Eur. J. Lipid Sci.Technol., 2006. – Vol. 108. – P. 776–793.
5. **Wargovich M. J., Woods C., Hollis D. M., Zander M. E.** Herbals, Cancer Prevention and Health // The Journal of Nutrition, Supplement, 2001. – P. 3034–3036.

Received 2010 06 12

C. Aküner, M. T. Tuncay. Flexible Product Drying System Design and Application // Electronics and Electrical Engineering. – Kaunas: Technologija, 2010. – No. 10(106). – P. 37–42.

Drying is removing the water in it with the various methods which cause quick spoil of the product. Increasing durability of the product by drying process, product quality influence such as appearance, color, taste, perfume, etc., and people's sense of appeal to the properties as possible protection, reduced energy consumption issues not overlooked. As a result of a high-quality drying process increases strength, reduces the volume and mass of the product. Control system of the rotary drum dryer has been developed which is previously designed and manufactured by the support of TUBITAK. Under Development National Instruments Company has produced the USB 6008 module LABVIEW program by using the operator intervention to ensure which were aimed clearly different variations of products in the drying process. In this study in the different profiles a wide range of products, with maximum quality and commercially low cost dryers, has been developed. Developed dryer is able to provide proper drying on each type of the product. By making appropriate changes on the operator panel of developed system can be performed drying for different products. III. 19, bibl. 5 (in English; abstracts in English and Lithuanian).

C. Aküner, M. T. Tuncay. Produktų džiovavimo sistemos projektavimas ir taikymas // Elektronika ir elektrotechnika. – Kaunas: Technologija, 2010. – Nr. 10(106). – P. 37–42.

Džiovinimo metu produktai gali būti sugadinti šalinant iš jų drėgmę. Esant aukštesniam džiovavimo laipsniui, sumažėja produktų tūris ir masė. Buvo sukurta valdymo sistema, skirta džiovavimo sistemai su besisukančiu būgnu. Pati džiovavimo sistema pagaminta anksčiau finansuojant projektą TUBITAK lėšomis. Vykdam šį projektą, buvo sukurtas programai LabVIEW USB 6008 skirtas modulis, kuriuo naudodamasis operatorius gali taikyti skirtingus ir skirtingų parametrų džiovavimo procesus. Buvo atlikti bandymai su nebrangiais džiovintuvais, užtikrinančiais maksimalią kokybę. Sukurta valdymo sistema įgalina kokybiškiau išdžiovinti produktus. Džiovinimo programos gali būti koreguojamos naudojantis sukurtos valdymo sistemos pulteliu. II. 19, bibl. 5 (anglų kalba; santraukos anglų ir lietuvių k.).

DOI: 10.5755/j02.eie.9114