

Practical Assessment of Synchronous Generator Dynamic Model Parameters

M. Ažubalis, V. Ažubalis, A. Jonaitis

Department of Electric Power Systems, Kaunas University of Technology,

Studentu str. 48, 51367 Kaunas, Lithuania, phone: +370 37 300287, e-mail: mindaugas.azubalis@ktu.lt

Introduction

Accuracy of power system stability investigation and reliability of the study results depends on the accuracy of the used dynamic models of generating units. More accurate models ensure more reliable evaluation of maximum permissible capacities of power flows, loadings of separate generating units and possibilities of transient processes control.

Identification of dynamic models for power system stability and transient studies requires large amount of information about the equipment and its characteristics. The lack of data may make uncertainties in evaluation of dynamic models of generating units as well as simulation of operating conditions of power system.

Dynamic model of synchronous generator

The synchronous generator may be presented by the operator expressions for the direct and quadrature axes:

$$\Delta\Psi_d(s) = G(s) \cdot \Delta u_{fd}(s) - L_d(s) \cdot \Delta i_d(s), \quad (1)$$

$$\Delta\Psi_q(s) = -L_q(s) \cdot \Delta i_q(s), \quad (2)$$

here $\Delta u_{fd}(s)$, $\Delta\Psi_d(s)$, $\Delta\Psi_q(s)$, $\Delta i_d(s)$, $\Delta i_q(s)$ is the exciter voltage; the variation of flux linkage and current components; $G(s)$ is the transfer function between rotor and stator; $L_d(s)$, $L_q(s)$ is the inductances in operator form of d and q axis.

The one-line diagrams corresponding to the (1) and (2) and representing the synchronous machine are shown in Fig. 1. The generator is presented as a set of n RL circuits connected in parallel for d and q axes.

The transfer functions of the generator's flux linkage and inductances are described as following [1]:

$$G(s) = G_0 \cdot \frac{(1 + sT_{d\ell 1})(1 + sT_{d\ell 2}) \dots (1 + sT_{d\ell n_d})}{(1 + sT'_{d0})(1 + sT''_{d0}) \dots (1 + sT^{n_d+1}_{d0})}, \quad (3)$$

$$L_d(s) = L_d \cdot \frac{(1 + sT'_d)(1 + sT''_d) \dots (1 + sT^{n_d+1}_d)}{(1 + sT'_{d0})(1 + sT''_{d0}) \dots (1 + sT^{n_d+1}_{d0})}, \quad (4)$$

$$L_q(s) = L_q \cdot \frac{(1 + sT'_q)(1 + sT''_q) \dots (1 + sT^{n_q+1}_q)}{(1 + sT'_{q0})(1 + sT''_{q0}) \dots (1 + sT^{n_q+1}_{q0})}, \quad (5)$$

here $T_{d\ell}$ is the flux linkage time constant; T_d and T_q is the short circuit time constants of d and q axes; T_{d0} and T_{q0} is the short circuit time constants of d and q axes; n_d and n_q is the number of circuits of d and q axes.

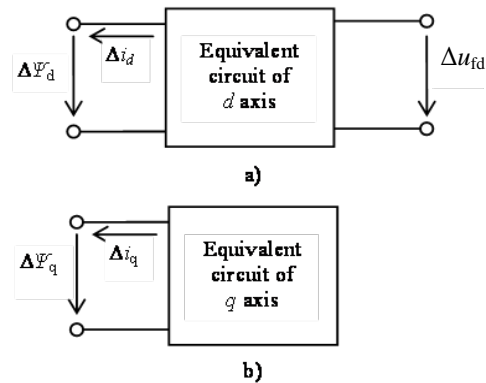

Fig. 1. Generalized schemes of the synchronous generator's direct axis (a) and quadrature axis (b)

In practice, two-circuit diagrams of d and q axes are used for modeling of synchronous generators [2].

The producing of synchronous generator dynamic models and the calculation of their parameters need to know the type of generator, and the nominal total power S_N , active power P_N , nominal power factor of $\cos\phi$, the nominal generator voltages and currents U_N and I_N , the field voltage and current U_{fN} and I_{fN} and the power diagram $Q_G=f(P_G)$.

The main generator dynamic parameters are the inductive reactance's of direct-axis and quadrature-axis, time constants of field winding at open circuit (no load)

and short circuit and rotor inertia. The detailed list of parameters used in dynamic model is presented in Table 1.

Table 1. Parameters of synchronous generator

Inductive reactance's and resistances, in p.u., at rated power and voltage S_N and U_N		
1.	d-axis synchronous inductive reactance	x_d
2.	q-axis synchronous inductive reactance	x_q
3.	d-axis transient inductive reactance	x'_d
4.	q-axis transient inductive reactance *	x'_q
5.	d-axis subtransient inductive reactance	x''_d
6.	q-axis subtransient inductive reactance	x''_q
7.	Leakage reactance	x_f
8.	Stator resistance	r_a
9.	Field circuit resistance **	r_f
Field circuit time constants		
10.	d-axis open circuit transient time constant **	T'_{d0}
11.	q-axis open circuit transient time constant *	T'_{q0}
12.	d-axis open circuit subtransient time constant	T''_{d0}
13.	q-axis open circuit subtransient time constant	T''_{q0}
Total inertia of generator, turbine and exciter		
14.	Inertia constant, s	T_J
15.	Moment of inertia, kgm^2 ($GD^2/4$) or	J
16.	GD^2 , kgm^2	GD^2
Open circuit saturation		
17.	Saturation at rated voltage U_N	$S(1.0)$
18.	Saturation at voltage $1.2U_N$	$S(1.2)$

Note: * is the parameter is not used for salient rotor (hydro) generators; ** – T'_{d0} and r_f are given at certain temperature of field winding during measurement.

The dynamic parameters of the synchronous generator can be identified according to two types of field tests:

- regime test – the disconnection of the generator loaded by only reactive load;
- frequency response test of the stopped generator.

Evaluation of dynamic model parameters according to regime test data

The dynamic parameters of the generator d -axis can be identified with sufficient accuracy according to the regime test data. During the test of unloaded generator which consumes the reactive power from the network, the terminal voltage and current are registered.

Processing of test data according to the voltage variation, the d -axis parameters x''_d , x'_d , x_d , T''_{d0} , T'_{d0} are determined.

Terminal voltage of the disconnected generator can be expressed as follows

$$U(t) = U_\infty + (U'_0 - U_\infty) \cdot e^{-\frac{t}{T'_{d0}}} + (U''_0 - U'_0) \cdot e^{-\frac{t}{T''_{d0}}} \quad (6)$$

or

$$U(t) = U_0 - I_0 \cdot x_d + I_0 \cdot (x_d - x'_d) \cdot e^{-\frac{t}{T'_{d0}}} + I_0 \cdot (x'_d - x''_d) \cdot e^{-\frac{t}{T''_{d0}}}, \quad (7)$$

here U_0 , I_0 , U_∞ is the initial voltage and current and the steady state voltage of the disconnected generator; U'_0 , U''_0

is the initial values of transient and sub transient voltages; T'_{d0} , T''_{d0} is the direct axis open circuit transient and sub transient time constants; x_d , x'_d , x''_d is the direct axis synchronous, transient and subtransient inductive reactance's.

The variation in voltage when the generator that is loaded with capacitive reactive load was switched off is shown in Fig. 2. The initial value of the sub transient voltage U''_0 can be expressed from the first voltage jump and a sub transient inductive resistance value can be found:

$$U''_0 = U_0 - I_0 \cdot x''_d, \quad (8)$$

$$x''_d = \frac{U_0 - U''_0}{I_0}. \quad (9)$$

At the subsequent voltage curve point (when the short-term voltage component extinct) derived tangent to the line that corresponds settled voltage U_∞ a direct axis transient time constant T'_{d0} can be determined.

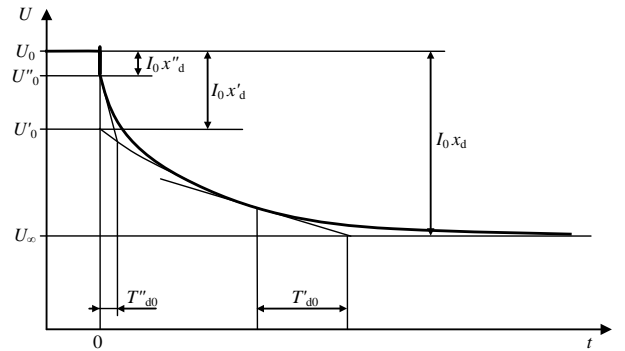

Fig. 2. The variation in voltage when the generator loaded with capacitive reactive load was switched off

Extrapolating the curve of the exponential transient voltage U' to the stoppage time the value of U'_0 is determined. According to it, the direct axis transient inductive resistance x'_d value is determined as follows

$$x'_d = \frac{U_0 - U'_0}{I_0}. \quad (10)$$

The d -axis synchronous inductive resistance value is determined similarly

$$x_d = \frac{U_0 - U_\infty}{I_0}. \quad (11)$$

Table 2. Typical ratios for the d and q axis generators parameters

Parameters	Non-salient pole generator	Salient pole generator
x_q	$0.9 x_d$	$(0.6-0.7) x_d$
x'_q	$1.5 x'_d$	–
x''_q	x''_d	x''_d
T'_{q0}	$0.3 T'_{d0}$	0
T''_{q0}	T''_{d0}	T''_{d0}

The value of the d -axis sub transient time constant T''_{d0} is defined by extrapolating the tangent at certain point of the U''_0 curve to the derived U' curve.

The leakage resistance of the stator inductive x_ℓ value is not normally determined with the tests. It can be assessed in accordance with the manufacturers' data or approximately - according to longitudinal resistance x_d : $x_\ell \approx 0.08 \cdot x_d$.

Appropriate parameters of the q axis can be extrapolated in accordance to typical d and q axis ratios that are presented in Table 2.

Evaluation of dynamic model parameters according to frequency response test of the stopped generator

The data of the stopped generator frequency response test allows identify the main parameters of the d and q axes: $x''_d, x'_d, x_d, T''_{d0}, T'_{d0}, x''_q, x'_q, x_q, T''_{q0}, T'_{q0}$ and resistances of the stator and rotor r_a and r_f .

During the test, stator voltage and current and rotor current instant values were recorded.

During the test data processing complex input reactance of the d and q axis – $Z_d(s)$ and $Z_q(s)$; transfer function rotor-stator $s \cdot G(s)$ for the different frequencies ($s=j\omega=j2\pi f$) are determined. Operator values of the inductances $L_d(s)$ and $L_q(s)$ determine estimating stator resistance:

$$L_d(s) = \frac{Z_d(s) - r_a}{s}, \quad (12)$$

$$L_q(s) = \frac{Z_q(s) - r_a}{s}, \quad (13)$$

here r_a – the active resistance of stator windings, measured during the test at the temperature of windings.

With operator transfer functions and inductance values and expanded with polynomial ratio the dynamic parameters of $L_d, T'_{d0}, T''_{d0}, T'_d, T''_d$ and $L_q, T'_{q0}, T''_{q0}, T'_q, T''_q$ are determined. Parameters normally used to determine by frequency identification methods [3].

During the rapid changes of measured value, when $s=j\omega \rightarrow j\infty$, marginal values of the inductances $L_d(s), L_q(s)$ will be equal to transient inductance values L''_d and L''_q . L''_d and L''_q are expressed following:

$$L''_d = L_d(j\infty) = L_d \cdot \frac{T'_d \cdot T''_d}{T'_{d0} \cdot T''_{d0}}, \quad (14)$$

$$L''_q = L_q(j\infty) = L_q \cdot \frac{T'_q \cdot T''_q}{T'_{q0} \cdot T''_{q0}}. \quad (15)$$

Dynamic expressions of the inductances without the damping windings (the second rotor contour, contour with large time constants) will be less complicated and expressed as follows:

$$L'_d = L_d(j\infty) = L_d \cdot \frac{T'_d}{T'_{d0}}, \quad (16)$$

$$L'_q = L_q(j\infty) = L_q \cdot \frac{T'_q}{T'_{q0}}. \quad (17)$$

Rotor poles of the hydro units that are made of the steel sheets and the free currents closes through damping windings of rotor transverse axis. Hydro generators that is usually modeled with "2.1" model, now are designed with one contour in the transverse axis [4]. In case when damping windings time constants are smaller than the excitation windings time constants, it is considered that there is no transient inductance or transient time constants, just transient inductance L''_q and the open circuit and short circuit time constants T''_{q0}, T''_q . Expression of the transient inductance L''_q is similar to the expression of the transient inductance of the turbo generator

$$L''_q = L_q(j\infty) = L_q \cdot \frac{T''_q}{T''_{q0}}. \quad (18)$$

The test of the frequency response for the stopped generator is recommended only when the routine maintenance is completed and the generating unit is off for long time.

In both cases of parameters' identification according to regime test and frequency response test of the stopped generator, the test temperature θ_B and the identified time constant T'_{d0B} must be taken into account and the value of excitation windings resistance r_{fB} need to be adjusted to the winding temperature of the nominal regime θ_N :

$$T'_{d0} = T'_{d0B} \cdot \frac{234.5 + \theta_B}{234.5 + \theta_N}, \quad (19)$$

$$r_f = r_{fB} \cdot \frac{234.5 + \theta_N}{234.5 + \theta_B}. \quad (20)$$

Evaluation of inertia constant

The inertia time constant T_J of the generating unit is determined from the generator tripping test, where the initial speed $\left. \frac{d\Delta\omega_*}{dt} \right|_{t=0}$ is measured and the generator is loaded with low active load ΔP_*

$$T_J = \frac{\Delta P_*}{\left. \frac{d\Delta\omega_*}{dt} \right|_{t=0}}. \quad (21)$$

The initial rotor speed should be recorded with sufficiently high sampling frequency, and the time interval should be within 0.01-0.1 s range.

During the test when unit operates under a small resistive load ($S_G = (0.1 \div 0.3) \cdot P_N + j0$ MVA) and is turned off by generator switch, a step output change is applied to the rotor $\Delta P_* = P_T$, which accelerates unit's rotor. An initial acceleration $d\omega/dt$ ($t=0$) is determined from the registered rotor speed change and a time constant of the unit inertia is determined according to (21).

Evaluation of saturation characteristic

Generator saturation values of $S(1.0), S(1.2)$ characteristics are determined by the open circuit (no load) characteristic (Fig. 3) [5].

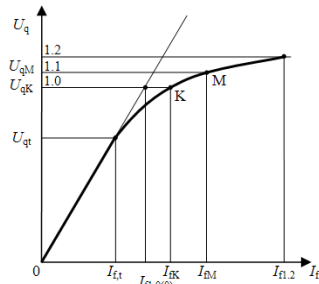

Fig. 3. Open circuit saturation characteristic

Any source voltage U_{qi^*} corresponding to the excitation current of I_{fi^*} can be expressed as follows

$$I_{fi^*} = U_{qi^*} + D \cdot e^{C(U_{qi^*} - U_{qt^*})} \quad (22)$$

and the values of the saturation curve:

$$S(U_{qi^*}) = \frac{D}{U_{qi^*}} \cdot e^{C(U_{qi^*} - U_{qt^*})}, \quad (23)$$

here U_{qi^*} and I_{fi^*} is the source voltage and field current at i^{th} point of open circuit characteristic; U_{qt^*} is the source voltage value at the end of linear characteristic; C and D is the coefficients of the approximated characteristic.

The open circuit characteristic is usually measured at 1.0 and 1.1 U_N and it continues to be extrapolated to 1.2 U_N .

According to the two nonlinear open circuit characteristic points K and M and the coordinates of the start of nonlinear approximation source voltage U_{qt} , the coefficients C and D are evaluated:

$$C = \frac{\ln \frac{I_{fK^*} - U_{qK^*}}{I_{fM^*} - U_{qM^*}}}{U_{qK^*} - U_{qM^*}}, \quad (24)$$

$$D = \frac{I_{fK^*} - U_{qK^*}}{e^{C(U_{qK^*} - U_{qt^*})}}, \quad (25)$$

here U_{qK^*} , U_{qM^*} , I_{fK^*} , I_{fM^*} , U_{qt^*} is the source voltage values and the corresponding excitation currents and the values of the nonlinearity start in source voltage expressed in per units.

Conclusions

The identification techniques of synchronous generators dynamic model's parameters according to the field test data are presented in the paper. The most informative method for evaluation of direct and quadrature axes parameters is frequency response test of a stopped generator. If the parameters are evaluated according to regime test data, only direct axis dynamic parameters can be determined directly and the quadrature axis parameters can be evaluated according to typical ratios.

References

1. **Kundur P.** Power System Stability and Control. – New York: McGraw-Hill, 1993. – 1176 p.
2. **Kamwa I., Farzaneh M.** Data Translation and Order Reduction for Turbogenerator Models Used in Network Studies // IEEE Transactions on Energy Conversion, 1997. – No. 2(12). – P. 118–125.
3. **Sayan H. H., Kahraman M., Kosalay I.** Simulation of Frequency Spectrum of Electric Power Signal // Electronics and Electrical Engineering. – Kaunas: Technologija, 2010. – No. 4(100). – P. 21–24.
4. **Topaloglu I., Ocak C., Tarimer I.** A Case Study of Getting Performance Characteristics of a Salient Pole Synchronous Hydrogenerator // Electronics and Electrical Engineering. – Kaunas: Technologija, 2010. – No. 1(97). – P. 57–61.
5. **Ljung L., Glad T.** Modeling of Dynamic Systems. – New Jersey: PTR Prentice Hall, 1994. – 361 p.

Received 2010 10 14

M. Ažubalis, V. Ažubalis, A. Jonaitis. Practical Assessment of Synchronous Generator Dynamic Model Parameters // Electronics and Electrical Engineering. – Kaunas: Technologija, 2010. – No. 10(106). – P. 33–36.

The paper presents analysis of evaluation methods of synchronous generator dynamic model parameters according to field test data. The list of parameters of the dynamic model for analysis of electromechanical transient processes and stability conditions in power systems is presented. The parameters of direct and quadrature axes can be evaluated according to frequency response test applied to the stopped generator. Regime tests of operating generator can be used for evaluation of direct axis parameters as well as for value of inertia constant. The open circuit characteristic is used for assessment of saturation characteristic. The methodic of parameters' evaluation is created and equations for their evaluation according to field test data are presented. Ill. 3, bibl. 5, tabl. 2 (in English; abstracts in English and Lithuanian).

M. Ažubalis, V. Ažubalis, A. Jonaitis. Sinchroninio generatoriaus dinaminio modelio parametru praktinis įvertinimas // Elektronika ir elektrotechnika. – Kaunas: Technologija, 2010. – Nr. 10(106). – P. 33–36.

Straipsnyje analizuojami sinchroninio generatoriaus dinaminio modelio parametru nustatymo pagal natūrinių eksperimentu duomenis metodai. Pateiktas dinaminio modelio parametru sąrašas elektros sistemų pereinamiesiems procesams ir stabilumo sąlygoms tirti. Išilginės ir skersinės ašies parametrai gali būti nustatomi sustabdžius generatorių dažninės reakcijos metodu. Veikiančio generatoriaus režiminiai eksperimentai gali būti taikomi išilginės ašies parametrams bei inercijos pastoviosios vertei nustatyti, o veikiančio tuščiąja veika – išotinio charakteristikos parametrams įvertinti. Sudaryta parametru nustatymo metodika ir pateiktos išraiškos jiems nustatyti naudojant natūrinių eksperimentu duomenis. Il. 3, bibl. 5, lent. 2 (anglų kalba; santraukos anglų ir lietuvių k.).

DOI: 10.5755/j02.eie.9113