

Research of the Grid-Tied Power System Consisting of Wind Turbine and Boiler GALAN

Č. Ramonas, V. Kepalas

*Department of Control Technology, Kaunas University of Technology,
Studentų str. 48, LT-51367 Kaunas, Lithuania, phone: +370 37 300274, e-mails: ceslovas.ramonas@ktu.lt,
vytautas.kepalas@ktu.lt*

V. Adomavičius

*The Centre for Renewables Energy Technologies, Kaunas University of Technology,
Studentų str. 48-329, LT-51367 Kaunas, Lithuania, phone: +370 37 351181; e-mail: vytautas.adomavicius@ktu.lt*

Introduction

New heat energy saving technologies presently used in civil engineering industry pave the way for development of even purely electrical space heating technologies in the buildings because heat energy demands in well-insulated buildings decrease substantially and electrical heating become acceptable and affordable. New technologies of thermal insulation at the same time facilitate implementation of renewable energy systems for the space heating in buildings including the wind-based ones. In Lithuania and other similar countries wind energy systems have the better possibilities because wind energy resources here are highest during the heating season (in winter) while solar energy resources at the same time are lowest. Therefore it is expedient to develop innovative wind energy systems, which utilize the power produced by the wind turbines (WT) locally for space heating in the buildings [1]. Locally utilized power of wind origin is not supplied into the electric grid and have not possibility for negative impact into the grid's stability. This is why local usage of wind power should be supported as much as possible and reasonable.

Buildings in windy regions have one of the largest untapped potentials for wind power utilization. One of the possible solutions is wind energy conversion directly into the heat energy [2]. However, transmission and distribution of the heat energy is much more complicated in comparison with power. Currently existing innovative electrical space heating technologies can be more suitable. For example, the electrode boilers of trade mark GALAN fed from electric grid are already used for space heating in buildings [3]. We suggest feeding of this boiler from the small grid-connected wind turbine and/or electric grid when wind is not blowing well enough. The WT should have a possibility to supply the surplus power into the electric grid when feeding of the boiler is not required. The

electrical scheme for implementation of this idea is proposed and researched in this paper.

Apart from the electrode boilers there are some other electrical space heaters, which can be combined with a small WT in order to reduce bills for electricity. First of all the infrared electrical space heaters could be mentioned. There are many types and varieties of infrared heaters in the market. They are manufactured as various panels, floor mats, small furnaces, lamps with concentrators of infrared rays. Producers of the infrared heaters claim that they save up to 40-50 % of electricity in comparison with the traditional convectional space heating systems and have some healing effect.

Summarising the presented information on electrical heaters it can be expected that penetration of the proposed innovative heating system into the buildings could be expedient in many aspects.

Usage of the wind energy system for space heating

Currently permanent magnet synchronous generators (PMSG) often are used in the WT of small capacity. Circuits of stator of the PMSG are connected with power grid over the converters. Such system of wind energy conversion can operate well enough at wide range of wind speeds. Stator circuit of the PMSG is connected with power grid over the inverter as it is shown in Fig. 1. The boiler is connected through normally opened (NO) contacts of contactor K to the grid terminals. This way of the boiler connection allows achieving of stabile space heating process independently on the wind speed. From other hand, it allows supplying of the wind turbine generated electricity into the electric grid when the boiler is switched out. As it is shown in Fig. 1, the matching transformer is necessary in this scheme in order to adjust the voltages of wind turbine's generator and electric grid. The voltages of the secondary windings of the matching

transformer can be calculated on basis of the maximal voltage of WT's generator by using equation presented in

the previous paper of authors [8].

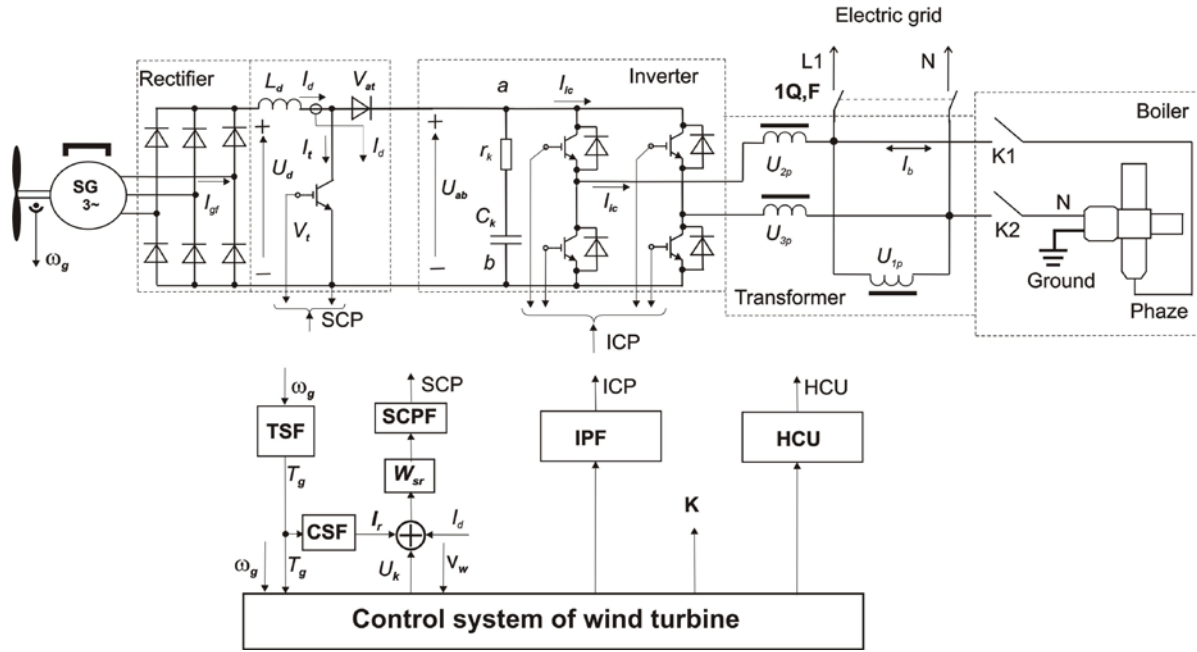

Fig. 1. Simplified electrical scheme of WT with PMSG for feeding the boiler „GALAN” and power supplying into electric grid

The generator parameters such as rated delta voltage U_{gN} , rated phase current I_{gfN} , the active resistance of the generator r_g , the inductance of the generator L_g are presented in its documentation. The rectified parameters of the PMSG can be calculated by formulas presented in the publications [4, 5]. The rectified internal voltage of the generator can be calculated by using the formula

$$u_{g0} = \frac{2\sqrt{2}m}{\pi} U_{gf} \sin \frac{2\pi}{m} \sin \frac{\pi}{m}. \quad (1)$$

Phase voltage of the generator can be expressed as this

$$U_{gf} = \frac{k_e \omega_g}{\sqrt{3}}, \quad (2)$$

where

$$k_e = \frac{U_{gN}}{\omega_{g0}}. \quad (3)$$

Effective phase current of the generator rotor depends on the rectified current and on the angle of diodes' commutation

$$I_{gf} = I_d \sqrt{\frac{2}{3} - \frac{\gamma}{3\pi}}. \quad (4)$$

The diodes' commutation angle γ can be calculated by using this formula

$$\gamma = \arccos \left(1 - \frac{\sqrt{2} x_K I_d}{\sqrt{3} U_{gf}} \right). \quad (5)$$

Voltage drop due to the commutation of rectifier's diodes u_K can be described by the following expression

$$u_K = \frac{m}{2\pi} x_K i_d, \quad (6)$$

where in formulas (1÷6): U_{gf} is the effective phase voltage of the generator's stator circuit; m – the number of pulsations of the rectified voltage; k_e – factor of the stator's internal voltage; ω_g – the angular speed of the rotor; x_K – the inductive resistance of the diodes commutation; i_d – the rectified current; γ – the commutation angle of the diodes.

It can be admitted for the evaluating calculations that $x_K \approx x_g$ (x_g – the inductive reactance of the generator's stator phase).

Mathematical descriptions of the electromagnetic processes taking place in the converter's power circuits have been made by using the simplifications well known in the theory of converters' circuits [4, 6]. So, the n -phase circuits of converter can be substituted by the one-phase equivalent scheme. Power switches can be considered as ideal. One-line scheme of the researched WT circuitry is shown in Fig. 2.

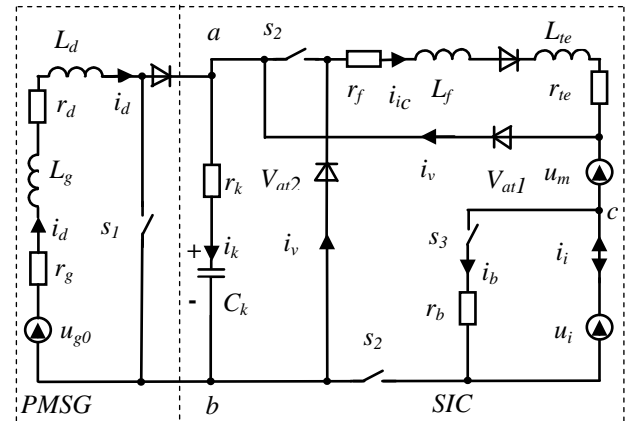

Fig. 2. Equivalent scheme of the wind turbine's power circuits

Equation of the grid's internal voltage can be described by means of Heaviside functions [7]. It will shape up as follows:

$$u_i = U_{im} \sum_{k=0}^{\infty} F(t - kT') \cdot \sin \left[\omega \cdot (t - kT') - \frac{2\pi}{m} - \varphi \right],$$

$$F(t - kT') = 1(t - kT') - 1[t - (k+1)T'], \quad (7)$$

where U_{im} is the maximum value of the inverter's (grid's) linear voltage; m – the number of pulsations for the inverter scheme; φ – the initial phase angle of the grid's internal voltage; ω – the cyclic frequency of grid voltage; $T' = T/m$ – the duration of operating interval, T – the period of grid voltage, $k = 0, 1, 2, 3, \dots$ - natural numbers.

As it is shown in previous works of authors [4] the load of PMSG generator (Fig. 2) operates in the two basic modes: the shorting mode – when the switch S_1 is closed, and the power inverting mode – when the switch S_1 is opened and switch S_2 is closed. When the generator's load is operating in the shorting mode (S_1 – ON) its power circuits can be described like as in reference [4]:

$$\begin{cases} \frac{di_d}{dt} = \frac{1}{L_d}(u_d - r_d i_d), \\ u_d = u_{g0} - u_g - u_K, \\ u_g = 2r_g i_d + 2L_g \frac{di_d}{dt}, \\ u_K = \frac{mx_K}{2\pi} i_d, \end{cases} \quad (8)$$

where u_g – the voltage of generator; i_d – the rectified current of generator; r_g – the active resistance of the phase winding of generator; r_d – the active resistance of the reactor; L_g – the inductance of the phase winding of generator; L_d – the inductance of the reactor.

When the switch S_1 is switching off and the switch S_2 is not switched on yet the generator's power circuits can be described as follows:

$$\begin{cases} \frac{di_d}{dt} = \frac{1}{L_d}(u_d - r_d i_d), \\ \frac{du_c}{dt} = \frac{1}{C_k} i_k, \\ U_{c0} = k_{si}(U_{ifm} + U_m), \\ U_c = U_{c0} + u_c, \\ u_d = u_{g0} - u_g - u_{ab} - u_K, \\ u_g = 2r_g i_d + 2L_g \frac{di_d}{dt}, \\ u_{ab} = U_c + r_k i_k, \\ u_K = \frac{mx_K}{2\pi} i_d, \\ i_d = i_k, \end{cases} \quad (9)$$

where U_{ifm} – the maximum value of the grid's phase voltage; U_m – the maximum value of the matching voltage; u_c – the voltage of the storing capacitor C_k ; i_k – the current of the storing capacitor C_k ; k_{si} – coefficient of the inverter's scheme.

When the generator is operating in the inverting mode (S_1 – OFF, S_2 – ON, S_3 – ON) its power circuits can be described by means of the system of differential and algebraic equations given below:

$$\begin{cases} \frac{di_d}{dt} = \frac{1}{L_d}(u_d - u_{ab} - r_d i_d), \\ \frac{di_{ic}}{dt} = \frac{1}{L_{ic}}(u_{ab} - u_m - u_{cb} - r_{ic} i_{ic}), \\ \frac{du_c}{dt} = \frac{1}{C_k} i_k, \\ u_m = k_t u_i, \\ u_d = e_{g0} - u_g - u_K, \\ u_g = 2r_g i_d + 2L_g \frac{di_d}{dt}, \\ u_K = \frac{mx_K}{2\pi} i_d, \\ U_{c0} = k_{si}(U_{ifm} + U_m), \\ U_c = U_{c0} + u_c, \\ u_{ab} = U_c + r_k i_k, \\ i_b = \frac{1}{r_b} u_i, \\ i_k = i_d - i_{ic}, \\ i_i = i_{ic} - i_b. \end{cases} \quad (10)$$

where u_i – the voltage of the grid; u_m – the matching voltage; k_t – transformation factor of the transformer; $r_{ic} = r_{te} + r_f$ – the active resistance of the inverter circuit; r_{te} – the active resistance of the transformer; r_f – the active resistance of the filter; $L_{ic} = L_{te} + L_f$ – the inductance of the inverter's circuit; L_f – the inductance of the filter; L_{te} – the inductance of the transformer; i_{ic} – the current of the inverter circuit; i_b – the boiler current; i_i – the grid (inverted) current.

When the switch S_1 is in the position OFF and the switch S_2 is just after the switching off (see Fig 2), the generator power circuits can be described by using system of equations (10) with some modifications: $u_i=0$, $i_i=0$ and current $i_k = i_d + i_{ic}$ (sign of i_{ic} changes).

When the switch S_1 is in the position ON and the switch S_2 is just after the switching off, the inverter power circuits can be described as follows:

$$\begin{cases} \frac{di_{ic}}{dt} = \frac{1}{L_{ic}}(u_{ab} + r_{ic} i_{ic}), \\ \frac{du_c}{dt} = \frac{1}{C_k} i_k, \\ U_{c0} = k_{si}(U_{ifm} + U_m), \\ U_c = U_{c0} + u_c, \\ u_{ab} = U_c + r_k i_k, \\ i_k = i_v = i_{ic}. \end{cases} \quad (11)$$

Mechanical system of the WT can be described like it was done in the papers [4, 7]:

$$\begin{cases} \frac{d\omega_g}{dt} = \frac{1}{J} \cdot (T_{tg} - T_g - T_f), \\ T_{tg} = \frac{P_t}{\omega_g}, \\ T_g = k_m \cdot I_f, \\ T_f = k_f \cdot \omega_g, \end{cases} \quad (12)$$

where T_g is the torque of generator; T_{tg} – the torque of wind turbine shaft calculated to the generator's rotor; T_f – the combined torque of viscous friction of rotor and load; J – the combined inertia of rotor and load; ω_g – the angular velocity of the generator's rotor; k_m – torque factor; k_f – friction factor; P_t – the power produced by the wind turbine.

Mathematical description of wind turbine

Synchronous generator with permanent magnets (PMSG) is rotated by the wind rotor of horizontal wind turbine. The power of WT is expressed by using the widely known formula

$$P_t = \frac{1}{2} \cdot \rho \cdot c_p(\lambda, \beta) \cdot A \cdot v_w^3, \quad (13)$$

where v_w – the wind speed; c_p – the power coefficient; $\rho = 1,225 \text{ kg/m}^3$ – is the air density; $A = \pi R^2$ – the swept area of the wind rotor.

The non-dimensional power coefficient c_p depends on the tip-speed ratio λ and blade pitch angle β . Coefficient λ can be calculated by using this formula

$$\lambda = \frac{R \cdot \omega_t}{v_w}, \quad (14)$$

where R is the radius of wind rotor; ω_t – the angular velocity of wind turbine rotor.

The coefficient c_p is described as follows

$$c_p(\lambda, \beta) = c_1 \left(\frac{c_2}{\lambda_i} - c_3 \beta - c_4 \beta^{c_5} - c_6 \right) \exp\left(\frac{-c_7}{\lambda_i} \right). \quad (15)$$

The value λ_i can be calculated by means of this formula:

$$\lambda_i = \left[\left(\frac{1}{\lambda + c_8 \beta} \right) - \left(\frac{c_9}{\beta^3 + 1} \right) \right]^{-1}, \quad (16)$$

where $c_1 = 0.73$, $c_2 = 151$, $c_3 = 0.58$, $c_4 = 0.002$, $c_5 = 2.14$, $c_6 = 13.2$, $c_7 = 18.4$, $c_8 = -0.02$, $c_9 = -0.003$.

Apart from the function of maximization of the power produced by the WT, the used control system has one more advantage: the system has a certain effect of filtration of various disturbances because it do not transmit into the control circuits any rapidly changing variations of the wind rotor power caused by the fluctuations of momentary wind speed and aerodynamic harmonics of torque.

Mathematical model of the system

Mathematical model of the researched system is shown in Fig. 3. It consists of the three main parts: the PMSG generator, the storage and inverting circuits and wind turbine unit.

Mathematical model for the PMSG is made up by using the systems of equations (8, 9, 10 and 12) as well as equations (1÷7). Mathematical model of the storage and inverting circuits is elaborated by application of the previously published works of the authors [4, 7].

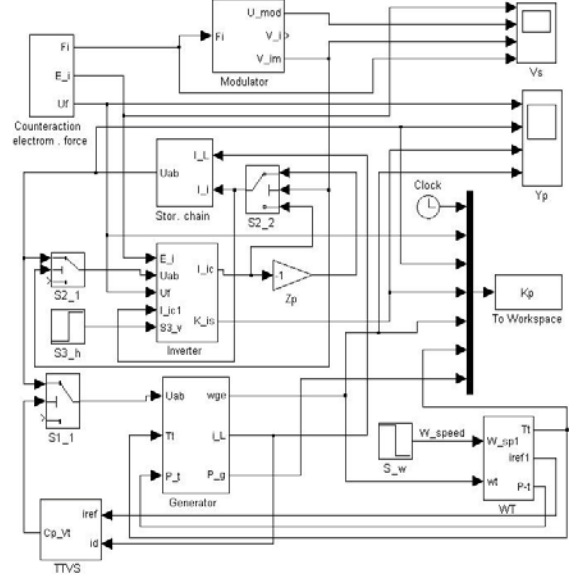

Fig. 3. Mathematical model of WT with PMSG for power supplying into the electrode boiler GALAN and electric grid

Mathematical model of the WT is based on the equations (13÷16). The reference rectified current I_r (Fig. 1) is calculated in the model's block WT according to the formula presented in the previous paper of the authors [4].

Results of the system's operation research

Wind turbine is purely non-linear object which is described by the non-linear equations (1, 4, 5, 7 equations and system of equations 12). This is why the method of mathematical modeling and simulation is chosen to research this system. The researches of the proposed wind energy consumption system based on the PMSG machine were carried out by using of MATLAB/SIMULINK programme package. Duration of simulation depends on the time constants of the researched system blocks. When the inertia of wind rotor is large and the time constants of converter are small, the duration of simulation is long. Therefore in our case the initial terms were used in order to decrease the time of simulation: it was considered that wind turbine is rotating with angular velocity close to the steady value, which depends on the value of wind speed.

The quality of response of the wind turbine into the control signal and wind speed changes was researched by means of the simulation. Results of simulation are presented below in form of experimental curves.

The made up mathematical model allows research of the WT and electrode boiler operation dependently on the various disturbances: load of the generator, wind speed and load made up by the electrode boiler GALAN. As it is shown in Fig. 4, after the jump of generator's load reference signal U_v from 6 to 7 V after 3 s, the inverted current and voltage on the inverter terminals suddenly increases. Meanwhile angular speed and torque of the WT decrease slowly due to the large inertia of the system. A moment later the inverted current and voltage on the inverter terminals decrease simultaneously and slowly. The torque of WT shaft after the drop of the wind speed v_w from 12 to 9 m/s after 5 s increases suddenly; however other parameters (the angular speed, the inverted current and voltage on the inverter terminals) increase slightly. Besides, power of the WT's generator and the rectified current at 5 s increases because the WT before of the wind speed drop was overloaded (Fig. 6). The inverted current suddenly decreases by the value of electrode boiler GALAN rated current at the time 7 s when this boiler is switched on. The rest variables practically stay stable (Fig. 4 – Fig. 5).

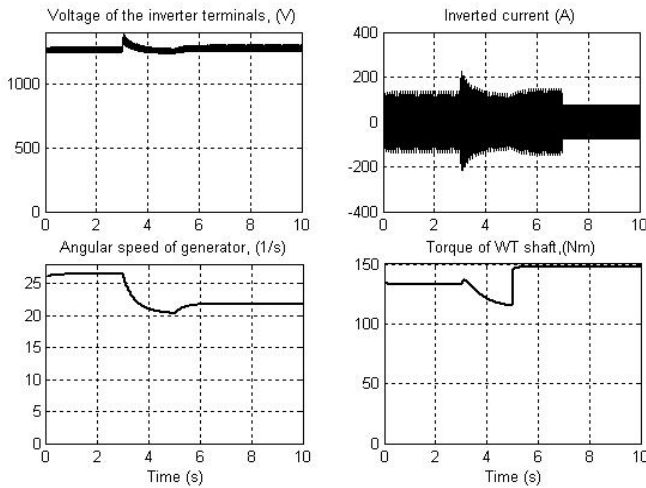

Fig. 4. Curves of the WT's power conversion system parameters at the jump of generator's load reference signal U_v from 6 to 7 V after 3 s, drop of the wind speed v_w from 12 to 9 m/s at $t = 5$ s and switching on the boiler feeding at $t = 7$ s

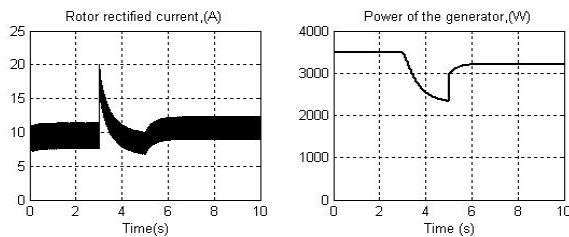

Fig. 5. Curves of the WT's power conversion system parameters at the jump of generator's load reference signal U_v from 6 to 7 V after 3 s, drop of the wind speed v_w from 12 to 9 m/s at $t = 5$ s and switching on the boiler feeding at $t = 7$ s

The curves in Fig. 6 are simulated at the similar conditions as the same curves shown in Fig. 4. The only difference is the limits of the wind speed drop – from 12 to 5 m/s at 5 s. As it can be noticed, the torque of WT shaft sharply decreases after 5 s while other variable parameters decrease slowly but significantly. It can be explained by

impact of large inertia of the WT. The inverter current drops down to zero value at the time 7 s because the electrode boiler GALAN is switched on at this moment and inverting process is interrupted. Fig. 7 shows that power of the generator drops down suddenly at this moment.

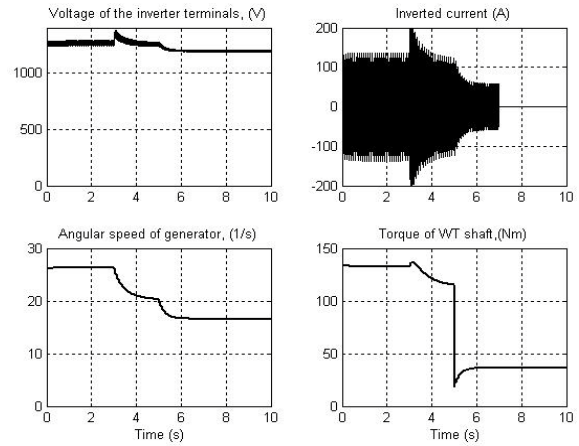

Fig. 6. Curves of the WT's power conversion system parameters at the jump of generator's load reference signal U_v from 6 to 7 V after 3 s, drop of the wind speed v_w from 12 to 5 m/s at $t = 5$ s and switching on the boiler feeding at $t = 7$ s

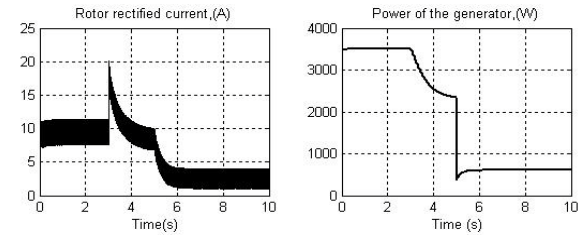

Fig. 7. Curves of the WT's power conversion system parameters at the jump of generator's load reference signal U_v from 6 to 7 V after 3 s, drop of the wind speed v_w from 12 to 5 m/s at $t = 5$ s and switching on the boiler feeding at $t = 7$ s

Meanwhile generator's rectified current decreases slowly (Fig. 7) due to the inertia of the WT. The electrode boiler will have to take the major part of power from the electric grid at these circumstances.

Conclusions

1. The scheme of small grid-connected wind turbine's power conversion system is proposed for feeding of electrode boiler of trade mark GALAN and supplying of the surplus power into the electric grid.
2. Mathematic model of the proposed system was worked out and researched.
3. Research performed by means of the mathematical model shows that proposed space heating system with two-position controller is operating smoothly and parameters of the power conversion system's electromagnetic process are in the permissible boundaries.
4. Research performed by means of the mathematical model also shows that proposed system allows utilisation of all power produced by the wind turbine very effectively.

5. Load of the wind turbine's generator in the proposed energy conversion system is controlled dependently on the wind speed in order to maximize the power output from the wind.
- References**
1. **Adomavičius V.** Sizing of wind-based energy system for homestead's power and heat // *Electrical and Control Technologies*, 2007. – KTU, IFAC Committee of National Lithuanian Organisation, Lithuanian Electricity Association. – P. 157–162
 2. **Katawaluwa M., et. al.** Simulation of Wind heat Generator. // *IEEE International Conference on Electro / Information Technology*, 2006. – P. 479–482.
 3. Электрические отопительные котлы ГАЛАН. Access over internet: www.galan.ru/products/galaks/index.shtml
 4. **Ramonas Č., Kepalas V., Adomavičius V.** Research of the usage of double-fed generators in wind turbines // *Electronics and Electrical Engineering*. – Kaunas: Technologija, 2009. – No. 8(96). – P. 27–32.
 5. **Gečys S, Smolskas P.** Parametrical optimization of equivalent circuit parameters of copper-squirrel-cage solid rotor induction motor supplied through long geophysical cable // *Electronics and Electrical Engineering*. – Kaunas: Technologija, 2009. – No. 2(90). – P. 73–76.
 6. **Poška A.–J., Zubaitis J.** Tiesiaieigės asinchroninės pavaros impulsinio dažnio keitiklio srovės skaičiavimas // *Elektrotechnika ir Elektronika*. – Kaunas: Technologija, 2003. – Nr. 1(43). – P. 37–42.
 7. **Kepalas V., Ramonas Č., Adomavičius V.** Connection of the RES-based Power Plants into the Electric Grid // *Electronics and Electrical Engineering*. – Kaunas: Technologija, 2007. – No. 8(80). – P. 67–72.
 8. **Ramonas Č., Adomavičius V.** Control of space heating system based on boiler GALAN and fed from wind power and electric grid // *Electrical and Control Technologies: proceedings of the 5th international Conference, ECT 2010*. – Kaunas University of Technology, IFAC Committee of National Lithuanian Organisation. – P. 303–308.

Received 2010 05 28

Č. Ramonas, V. Kepalas, V. Adomavičius. Research of the Grid-Tied Power System Consisting of Wind Turbine and Boiler GALAN // *Electronics and Electrical Engineering*. – Kaunas: Technologija, 2010. – No. 10(106). – P. 27–32.

Space heating system consisting of small-scale wind turbine and boiler GALAN is proposed and researched in this paper. Usually boiler GALAN is fed from the electric grid. The proposed system has the small wind turbine with permanent magnet synchronous generator, which feeds the boiler when the wind is blowing. In case when wind speed is too low, the boiler is fed from electric grid. In cases when the boiler does not consume all power of wind turbine or in summer, feeding of the boiler can be disconnected and the surplus power of wind turbine is supplied into electric grid. The two-step controller is used for the control of the space heating process. The power of wind turbine is also supplied into the electric grid during the pauses of power supply to the electrode boiler. The boiler can be additionally fed from the electric grid when power of the wind turbine is insufficient. Mathematic description and model for the proposed space heating system was worked out and researched. Research of the mathematical model disclosed that the system based on small-scale wind turbine and boiler GALAN is viable. The proposed system allows diminishing of the bills for electricity consumed for the space heating in a desirable amount. Ill. 7, bibl. 8 (in English; abstracts in English and Lithuanian).

Č. Ramonas, V. Kepalas, V. Adomavičius. Į elektros tinklą integruotos vėjo elektrinės su elektrodiniu katilu GALAN sistemos tyrimas // *Elektronika ir elektrotechnika*. – Kaunas: Technologija, 2010. – Nr. 10(106). – P. 27–32.

Straipsnyje pateikti į energetikos sistemos elektros tinklą integruotos patalpų šildymo sistemos, sudarytos iš mažosios vėjo elektrinės ir elektrodinio katilo GALAN, tyrimo rezultatai. Tradiciškai elektrodinis katilas GALAN yra maitinamas vien tik iš elektros tinklo. Autorių pasiūlyta patalpų šildymo sistema turi nedidelės galios vėjo elektrinę, kurioje naudojamas sinchroninis generatorius su nuolatiniais magnetais. Kai vėjo greitis yra pakankamas, elektrodinis katilas maitinamas iš mažosios vėjo elektrinės, o kai vėjo nėra arba kai jis yra per silpnas, – iš elektros tinklo. Visais atvejais, kai elektrodinio katilo maitinti nereikia, vėjo elektrinės generuojama elektros energija per inverterį tiekama į elektros tinklą. Patalpų šildymo procesui valdyti naudojamas dviejų pozicijų reguliatorius. Mažosios vėjo elektrinės energija taip pat tiekama į elektros tinklą reguliatoriaus diktuojamų pauzių metu, kai elektrodiniam katilui energija netiekama. Kai vėjo elektrinė veikia, bet jos galios nepakanka, trūkstama galios dalis imama iš elektros tinklo. Patalpų šildymo sistemai tirti buvo sudarytas jos matematinis aprašas ir matematinis modelis. Atlikti matematinio modelio tyrimai parodė, kad pasiūlytos patalpų šildymo sistemos su vėjo elektrine ir elektrodiniu katilu pagrindiniai pereinamieji procesai atitinka kokybės reikalavimus. Sistema funkcionuoja gerai. Įdiegus tokią sistemą būtų galima norimu dydžiu sumažinti sąskaitas už elektros energiją, paimtą iš elektros tinklo ir suvartotą patalpoms šildyti priklausomai nuo parinktos vėjo elektrinės galios. Il. 7, bibl. 8 (anglų kalba; santraukos anglų ir lietuvių k.).

DOI: 10.5755/j02.eie.9112