

Model of Ventilation System Drive with Fuzzy Controller

S. Lisauskas, R. Rinkevičienė

Department of Automation, Vilnius Gediminas Technical University,
Naugarduko str. 41, LT-03227 Vilnius, Lithuania, phone: +370 5 275013, e-mails: saulius.lisauskas@el.vgtu.lt,
roma.rinkeviciene@el.vgtu.lt

Introduction

At present Fuzzy logic is applied in various control aeries. It is used in consumer products, such as washing machines, microwave ovens, rice cookers, vacuum cleaners, camcorders, TVs and VCRs, thermal rugs, word translators. Fuzzy logic is applies in systems: elevators, train, cranes, automotive (engines, transmissions, brakes), traffic control and software: medical diagnosis, securities, data compression [1–3]. It is used for control of electric drives and electric networks. The electromechanical servo drive with variable structure of velocity controller commanded by Fuzzy logic based control law (*PI-PPI*) switching device is used for *P* control law duration time definition in dependence on the static load level of the drive [4]. Applied fuzzy logic control method improves optimal dynamical quality of the control process independently on the drive load conditions. Here two types (Mamdani-type and Sugeno-type) Fuzzy logic devices for *P* control law duration time definition have been designed and investigated [4]. In the paper [5] applications of fuzzy techniques for load estimations and determination of energy loss in distribution network are considered. Numerical results make obvious presented method is rather precise, robust and simple to apply. Control of induction motors with fuzzy PI controller ensures motor starting with approximately constant and relatively large torque, while starting torque with PD controller is more oscillating [6]. Fuzzy logic operates by knowledge-based way, where knowledge is described by linguistic if – then rules.

The paper considers model of closed loop ventilation system with Fuzzy controller. The system is driven by induction motor controlled by scalar law.

Fuzzy controller

Modern premises usually are equipped with advanced ventilator systems. Those are used in living or industrial premises. The requirements specification of the system depends on the premise destination. The main electric equipment of ventilation system is ventilator. Modern ventilation systems are equipped with frequency

controlled induction motors. Because of slow transients the induction motors do not require vector control systems. Usually ventilation systems use scalar control of frequency converters with PI or PID regulators. The Fuzzy controller is used to replace PI or PID controller. The architecture of considered speed control system is similar to that in [6]. Input of Fuzzy controller is error e , determined as difference between reference and measured pressure and change of error Δe that is the derivative of speed error. Output, defined as control input of V/F block, produces input signal for discrete PWM generator. The Fuzzy controller includes four major blocks: a fuzzification block, an inference mechanism, rule base and the last step is defuzzification [1]. The fuzzification module transforms the physical values of the current process signal, the error signal which is input to the fuzzy logic controller, into a normalized fuzzy subset consisting of a subset (interval) for the range of the input values and an associate membership function describing the degrees of the confidence of the input belonging to this range. The purpose of this fuzzification step is to make the input physical signal compatible with the fuzzy control rule base in the core of the controller. Fig. 1 shows membership functions for input variables e and Δe .

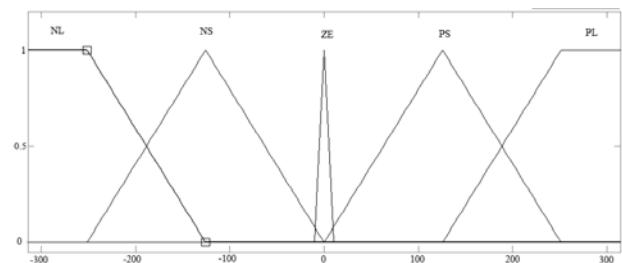

Fig. 1. Triangular membership functions for input variables e and Δe

Fig. 2 and Table 1 show the proposed membership functions for output variable and the control rules. The inference strategy used in this system is the Mamdani algorithm, and the center-of-area/gravity method is used as the defuzzification strategy.

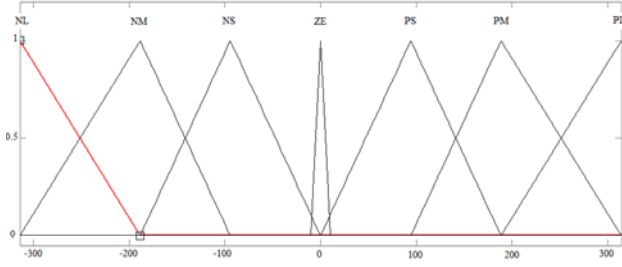

Fig. 2. Triangular membership functions for output variable

The fuzzy sets are designated by the labels: NL (negative large), NM (negative medium), NS (negative small), ZE (zero), PS (positive small), PM (positive medium), and PL (positive large).

Gain coefficients K_d , K_p , K_o are used for tuning of Fuzzy controller.

Table 1. Linguistic Rule Table

$\Delta e \backslash e$	NL	NS	ZE	PS	PL
NL	ZE	PL	ZE	PL	ZE
NS	NS	ZE	ZE	PL	ZE
ZE	NS	NL	ZE	PL	PS
PS	ZE	NL	PL	ZE	PS
PL	ZE	NL	PS	NL	ZE

Dynamic model of induction motor drive

There are used a lot of modifications of mathematical models of induction motors [7–10] and everyone finds its area of application. The main of them are phase coordinate model or its Park transformation, where different speed of revolution of reference frame is used. If the flux linkages of motor are assumed as state variables, then motor equations in synchronously rotating frame ω_e looks like this:

$$\begin{cases} \frac{d\psi_{qs}}{dt} = U_{1m} \cos \gamma - \omega_e \alpha'_s \psi_{qs} + \omega_e \alpha'_s K_r \psi_{qr} + \omega_e \psi_{ds}, \\ \frac{d\psi_{ds}}{dt} = U_{1m} \sin \gamma - \omega_e \alpha'_s \psi_{ds} + \omega_e \alpha'_s K_r \psi_{dr} - \omega_e \psi_{qs}, \\ \frac{d\psi_{qr}}{dt} = -\omega_e \alpha'_r \psi_{qr} + \omega_e \alpha'_r K_s \psi_{qs} + \omega \psi_{dr}, \\ \frac{d\psi_{dr}}{dt} = -\omega_e \alpha'_r \psi_{dr} + \omega_e \alpha'_r K_s \psi_{ds} - \omega \psi_{qr}, \end{cases} \quad (1)$$

where ψ_{qs} and ψ_{ds} are q-axis and d-axis stator flux linkages respectively, U_{1m} is amplitude of phase voltage, γ is voltage phase at switching instant, ω_e is angular frequency of voltage, equal $\omega_e = 2\pi f$; f is frequency of supply voltage in Hz; $\alpha_s = \frac{R_s}{x_s}$; $\alpha_r = \frac{R_r}{x_s}$;

$$\sigma = 1 - \frac{x_m^2}{x_r x_s}; \quad K_s = \frac{x_m}{x_s}; \quad K_r = \frac{x_m}{x_r}; \quad \alpha'_r = \frac{\alpha_r}{\sigma};$$

$\alpha'_s = \frac{\alpha_s}{\sigma}$. The other designations: x_m is magnetizing

reactance, $x_s = x_m + x_{ls}$ is total reactance of stator winding, $x_r = x_m + x_{lr}$ is total reactance of rotor, R_s is stator resistance, R_r is rotor resistance referred to stator, x_{ls} , x_{lr} is stator and rotor leakage reactance respectively.

Coefficients of (1) are calculated from the given parameters of motor.

Motor develops torque, calculated as

$$T = \frac{3}{2} p \frac{\omega_e K_r}{\sigma x_s} (\psi_{qr} \psi_{ds} - \psi_{qs} \psi_{dr}). \quad (2)$$

Set of equations (1) and (2) are supplemented with equation of movement

$$\frac{d\omega}{dt} = \frac{1}{J} (T - T_L), \quad (3)$$

here T and T_L are developed and load torque respectively, J is inertia, ω is speed of the rotor.

Model of induction motor drive consisting of dq model of induction motor, Fuzzy speed controller, discrete PWM generator, V/Hz block, universal bridge and ABC to dq converter unit is shown in Fig. 3. Voltages U_A , U_B and U_C are transformed to U_d , U_q voltages by formulas, given in [9].

Model of induction motor with ventilator load

If the motor drives pump or ventilator, it operates with ventilator load. Then load torque is proportional to speed square

$$T_L = k \cdot \omega^2. \quad (4)$$

Rated torque of motor is calculated as

$$T_r = \frac{P}{\omega_0}, \quad (5)$$

here P is motor power in watts, ω_0 is synchronous speed in rad/s. Rated parameters are given in Table 2.

Constant k is calculated from (5) in this way:

$$k = \frac{T_r}{\omega_0} = 1,29 \cdot 10^{-4}. \quad (6)$$

Model of frequency controlled drive with ventilator load is given in Fig. 1.

Motor model “AC motor” has 3 inputs: voltages U_{qs} , U_{ds} and torque load, proportional to speed square.

Parameters of modeled motor are presented in Table 2.

Response of torque, developed by motor is presented in Fig. 5. The torque peak approximately 6 times exceeds the rated torque. The steady-state value is equal to rated that and oscillates because higher order harmonics of current. The torque load response is given in Fig. 6. Steady state value of torque differs from rated torque by 3 %.

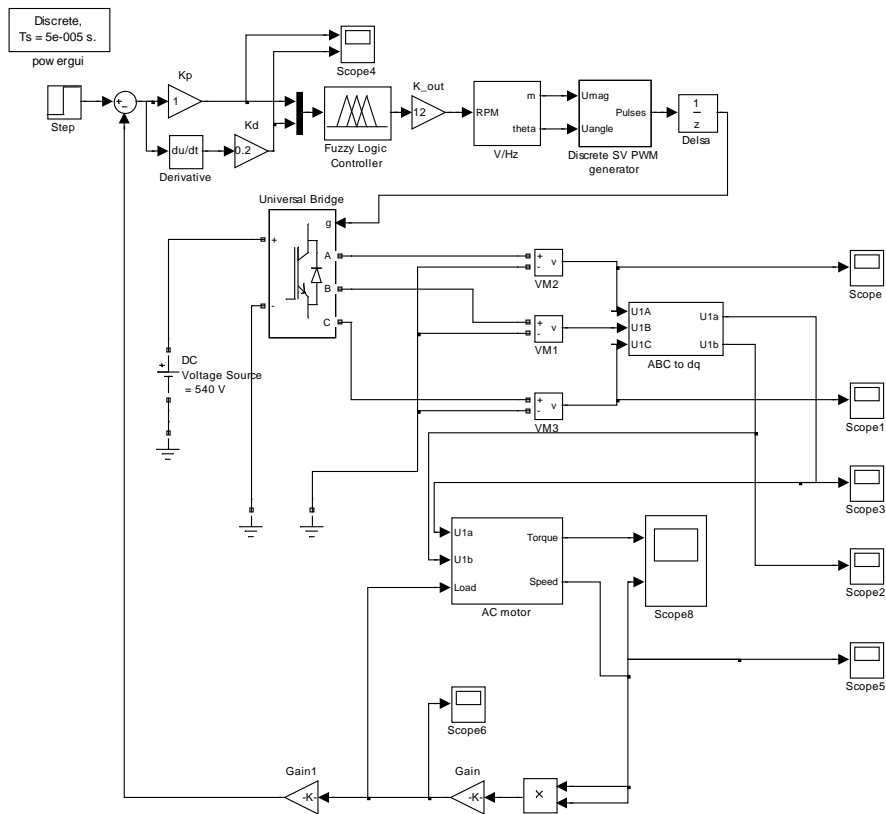

Fig. 3. Simulink model of induction motor drive

Table 2. Parameters of induction motor

Parameter	Value
Rated voltage [V]	400
Frequency [Hz]	50
Rated current [A]	7.9
Rated power [kW]	4
Speed [rpm]	2890
Power factor	0.88
Rated torque [N·m]	7.9

Results of simulation

Speed response is given in Fig. 4. Motor, starting with ventilator load in closed loop system, reaches the steady state value, close to synchronous that. The speed ripples are defined just in the beginning of process.

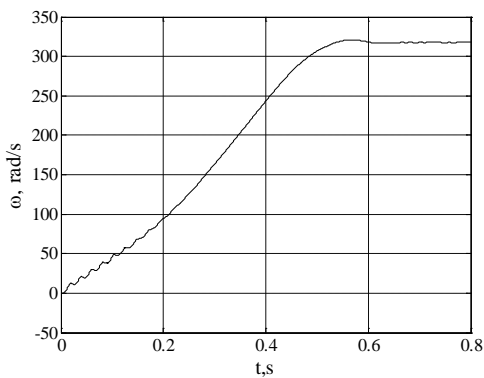

Fig. 4. Speed response of induction motor

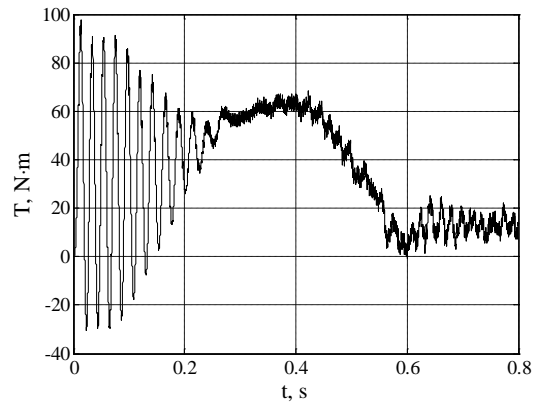

Fig. 5. Response of torque

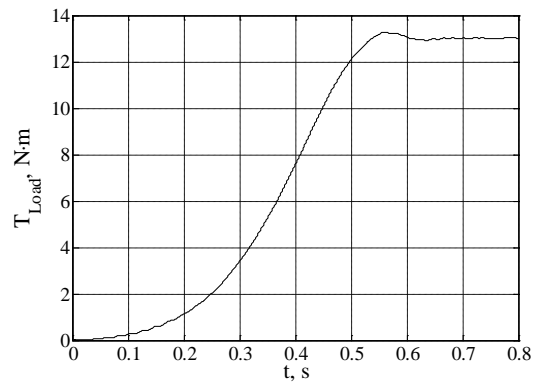

Fig. 6. Load torque

Transient of motor phase current is given in Fig. 7. Settling time is approximately equal to 0.6 s. Steady state current differs from rated that about 10 %.

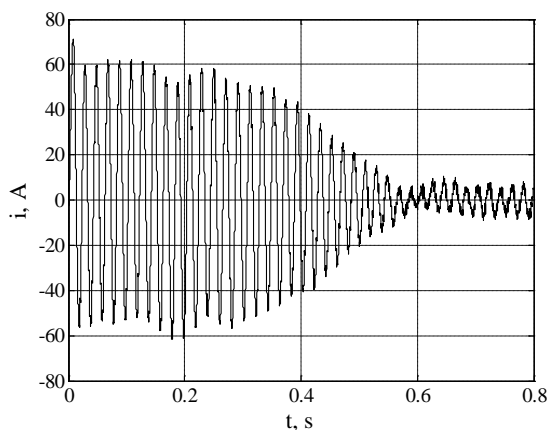

Fig. 7. Phase current

Two inputs of Fuzzy controller error and its derivative are presented in Fig. 8. Both signals took part in producing control signal of frequency inverter.

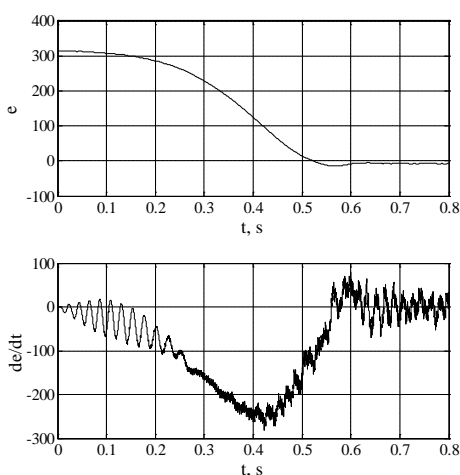

Fig. 8. Inputs of Fuzzy controller: error e and its derivative de/dt

Conclusions

Speed of motor operating in ventilation system at ventilator load exceeds the synchronous speed by 3 % during starting transients.

Speed of motor operating in ventilation system at ventilator load exceeds the synchronous speed by 3 % during starting transients.

The starting torque peak more than 7.4 times exceeds rated torque.

The phase current at starting more than 8.9 times exceeds rated current.

References

1. **Reznik L.** Fuzzy Controllers. – Newness, Printed in Great Britain by Biddles Ltd, Guildford and King's Lynn, 1997. – 307 p.
2. **Duka A. V., Abrudean M.** Simulation of a Fuzzy-PD Learning Control System // 1-4244-2577-8/08©2008 IEEE. Authorized licensed use limited to: Vilnius Gediminas Technical University. Downloaded on July 8, 2009 at 12:56 from IEEE Explore.
3. **Chen G., Pham T. T.** Introduction to Fuzzy Sets, Fuzzy Logic and Fuzzy control systems. – CRC press, 2001. – 328 p.
4. **Sulčius V., Geleževičius A.** Implementation of the Control Algorithm of the Variable Structure Controller in the Electromechanical Servo System // Electronics and Electrical Engineering. – Kaunas: Technologija, 2006. – No. 7(71). – P. 51–54.
5. **Bobric C. E., Cartina G., Grigoras G.** Fuzzy Technique used for Energy Loss Determination in Medium and Low Voltage Networks // Electronics and Electrical Engineering. – Kaunas: Technologija, 2009. – No. 2(90). – P. 95–98.
6. **Lisauskas S., Rinkevičienė R., Petrovas A., Batkauskas V.** Induction motor drive with Fuzzy controller // Proceedings of XIX-th International Conference on Electromagnetic disturbances, EMD 2009. – P. 127–130.
7. **Schröder D.** Elektrische Antriebe. – Regelung von Antriebssystemen. Springer, 2001. – 1172 s.
8. **Grouni S., Ibtouen R., Kidouche M., Touhami O.** Real Time Rotor Flux Estimation for Induction Machine Drives: an Experimental Approach // Electronics and Electrical Engineering. – Kaunas: Technologija, 2010. – Nr.8 (104). – P. 69–72.
9. **Bounadja M., Belmadani B., Belarbi A. W.** A Combined Stator Vector Control – SVM-Direct Torque Control for High Performance Induction Machine Drives // Electronics and Electrical Engineering. – Kaunas: Technologija, 2009. – Nr. 8 (96). – P. 54–57.
10. **Rinkevičienė R., Petrovas A.** Modelling of Frequency controlled induction drive with ventilator load // Electronics and Electrical Engineering. – Kaunas: Technologija, 2009. – Nr. 6 (94). – P. 69–73.

Received: 2010 10 10

S. Lisauskas, R. Rinkevičienė. Model of Ventilation System Drive with Fuzzy Controller // Electronics and Electrical Engineering. – Kaunas: Technologija, 2010. – No. 10(106). – P. 13–16.

Simulation model of ventilation system with fuzzy controller is elaborated and considered. System comprises scalar control induction motor drive with Fuzzy controller and overpressure feedback. Overpressure error and derivative of error are assumed inputs of Fuzzy controller. Output, defined as control input of V/F block, produces input signal for discrete PWM generator. Simulation results of speed, electromagnetic torque, and motor phase current and overpressure error and its derivative are presented and considered. III. 8, bibl. 10, tabl. 2 (in English; abstracts in English and Lithuanian).

S. Lisauskas, R. Rinkevičienė. Ventiliacijos sistemos pavaros su neraiškioju reguliatoriumi modelis // Elektronika ir elektrotechnika. – Kaunas: Technologija, 2010. – Nr. 10(106). – P. 13–16.

Sudarytas ir ištirtas ventiliacijos sistemos su neraiškioju reguliatoriumi modelis. Sistemą sudaro skaliarinio valdymo asinchroninė pavaros su neraiškioju reguliatoriumi ir slėgio grįžtamuoju ryšiu. Neraiškiojo reguliatoriaus įėjimai yra viršslėgio paklaida ir paklaidos išvestinė. Išėjimo signalas patenka į valdymo bloką, palaikantį pastovų įtampos ir dažnio santykį, kurio išėjimo signalas siunčiamas PWM generatoriui. Pateikti ir aptarti variklio greičio, elektromagnetinio momento, variklio fazinės srovės, viršslėgio paklaidos ir jos išvestinės imitaciniai rezultatai. II. 8, bibl. 10, lent. 2 (anglų kalba; santraukos anglų ir lietuvių k.).

DOI: 10.5755/j02.eie.9108