

Modelling and Analysis of Switching Overvoltages Caused by Short Circuits in MV Cables Connected with Overhead Lines

M. Hashmi, M. Lehtonen

*Department of Electrical Engineering, Aalto University,
Otakaari 5, 02015, Espoo, Finland, phone: +358 40 1594360, e-mails: murtaza.hashmi@tkk.fi, matti.lehtonen@tkk.fi*

S. Hänninen

*Department of Energy Systems, VTT Technical Research Centre of Finland,
Tekniikantie 2, 02015, Espoo, Finland*

Introduction

In rural power distribution networks, the cause of disturbances is typically weather related, like thunder, snow and ice, and trees fallen by snow, wind and storms [1]. In areas supplied by overhead lines, an auto-reclosure sequence is commonly used to clear temporary faults. In these areas, the share of permanent faults is typically less than 10% [1, 2]. In Finland, on average, about 70% of permanent faults in rural MV networks are caused by weather conditions such as thunder, snow, icing, storm, hard wind and fallen trees [1]. However, the cause of the majority of faults remains unknown when they are cleared automatically. Typically, no statistics of the causes of temporary faults is available in literature [3].

Generally, the most common fault type is the single-phase earth fault [1]. However, during lightning storms, short-circuits may represent a considerably higher share of the experienced faults. Short-circuits are stressful and severe faults, causing, in addition to interruptions, sagged voltages [2]. On the other hand, if short-circuit occurs and fuse is operated, overvoltage transients are produced in the networks. Fuse is a current limiting device, which can chop the current if there is short-circuit. The capacitive-inductive system may lead to high overvoltages. A common practice is to install surge arresters to reduce the effect of such kind of overvoltage transients. In this paper, overvoltages are studied and the need of installing MOVs is investigated.

The primary goal in surge arrester design is to provide the most reliable overvoltage protection for an electric power system network at the most reasonable cost [4]. By applying MOVs across the power circuit, it will divert a potentially high surge current from entering the main circuit and causing component failure. In normal operation, MOV has very high impedance and it can be considered as an open circuit. Whenever a transient fault occurs in the circuit, the MOV will respond extremely fast

by short-circuiting to avoid large current flow through the device [5, 6, 9] MOV has high resistance at lower voltage (at power frequency) and transforms to low resistance at high voltage (at high frequency). Therefore, its behaviour is in the form of a highly nonlinear current-voltage characteristic.

The main drawbacks of MOV arresters are that they are relatively slow to respond to very steep surges, and sensitive devices such as transistors may fail because of this delay. Also the capacitance of device is high due to pressed zinc oxide disks [7]. MOV arresters have advantages over other types, which make them ideal in many situations. These advantages are: (i) relatively simple in construction, (ii) easy to manufacture, (iii) low cost, and (iv) ability to absorb large surge currents. For these reasons, almost all arresters in high power/high voltage electrical circuits are of this type.

MV network description under investigation

The single-line diagram of the distribution network under investigation is shown in Fig. 1 The network is a combination of overhead line and underground cable. A fuse is inserted at a point near the coupling of overhead line and cable to limit the higher currents flowing in the cable. If a three-phase short-circuit occurs in the cable end near the distribution transformer, the fuse inserted in the beginning of the cable lateral (branch) may blow, and switching transients and possible over voltages may appear on the cable.

The fuse is current limiting device, so it is possible that the fuse blows at the current peak. After the interruption, the energy stored in the cable inductances will start to oscillate between the voltage in capacitance and current in the inductance, perhaps leading to very high over voltages.

The mitigation is possibly made by moving the surge arresters in the beginning of the cable lateral to the load

side of the fuse. The effect of this moving is investigated in this report. It will be decided which of two surge arresters (among SA-1, SA-2, and SA-3 as shown in Fig. 1) will be installed to reduce the effect of switching transients and over voltages appeared in the cable. The simulations have been carried out using electromagnetic transient program-alternative transient program (EMTP-ATP) in the next section.

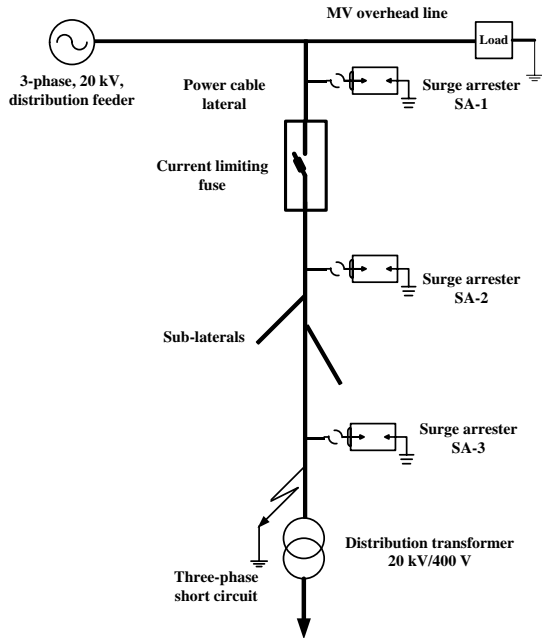

Fig. 1. MV distribution network under investigation to investigate over voltages produced due to blowing fuse

Modelling different scenarios under investigation

In this project, the ATPDraw is used as a graphical interface to model the overvoltage protection schemes for the MV network shown in Fig. 1. The models for MV overhead line, fuse, MOV, and cables are drawn. The distribution transformer model is used for high frequency applications [8]. The following scenarios have been investigated during simulations as; (a) there is no surge arrester installed in the network as well as there are no sub-laterals connected in the network, (b) there is no surge arrester installed in the network, however, sub-laterals are connected in the network, (c) one surge arrester on each side of the fuse (SA-1 and SA-2), i.e. at both ends of the fuse, are installed and sub-laterals are connected in the network, (d) ne surge arrester before the fuse and other near cable end (SA-1 and SA-3) are installed and sub-laterals are connected in the network, and (e) one surge arrester after the fuse and other near cable end (SA-2 and SA-3) are installed and sub-laterals are connected in the network.

The overvoltage protection is carried out using MOV. The non-linear voltage-current (V-I) characteristic of the MOV used for the simulations are drawn in Fig. 2. The simulation results for the aforementioned different scenarios (a, b, c, and d) have given extracted to analyse and design the possible protection schemes for mitigating overvoltage transients in MV networks, however, simulations results for scenarios (a) and (d) are only

presented in this paper, and are given in following sub-sections.

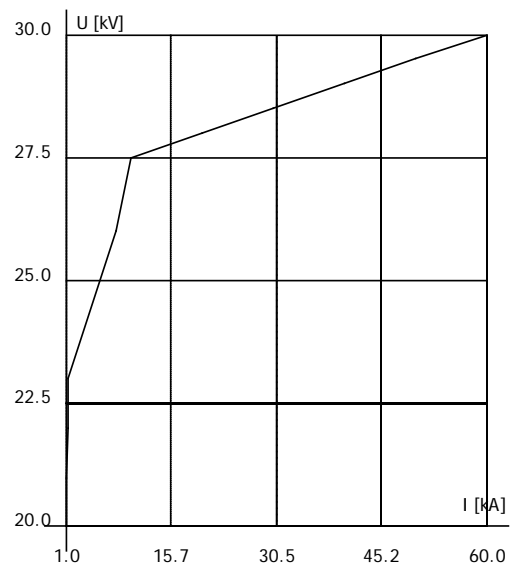

Fig. 2. V-I characteristic curve for 20 kV MOV arrester (8/20 μ s) [V: residual voltage and I: discharge current]

Simulation results for different scenarios

The ATP model for scenario (a) is drawn in Fig. 3. The length of the cable is 6 km, and no overvoltage protection is provided in the cable network. The overvoltages at junction of overhead line and cable are shown in Fig. 4, while the overvoltages at far end of cable near short-circuit point are shown in Fig. 5.

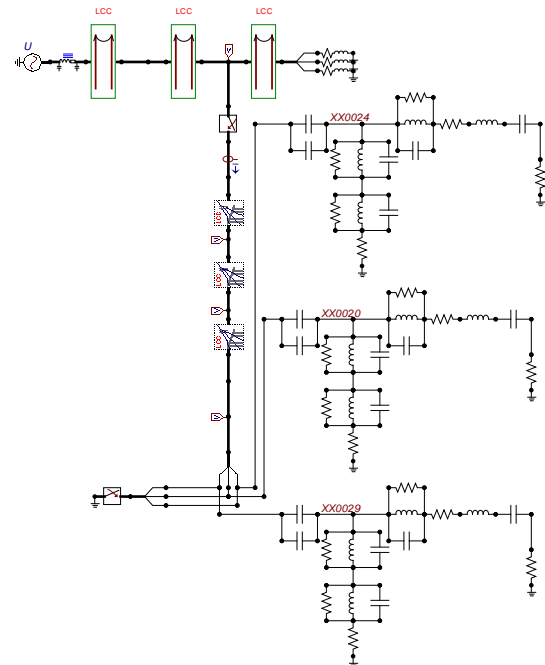

Fig. 3. ATP model of the MV network shown in Fig. 1 or scenario (a)

The ATP model for scenario (d) is drawn in Fig. 6. The length of the cable is 6 km, and overvoltage protection is provided in the cable network with two surge arresters

SA-1 and SA-3. Two cable sub-laterals each having length 1 km, are connected in the network.

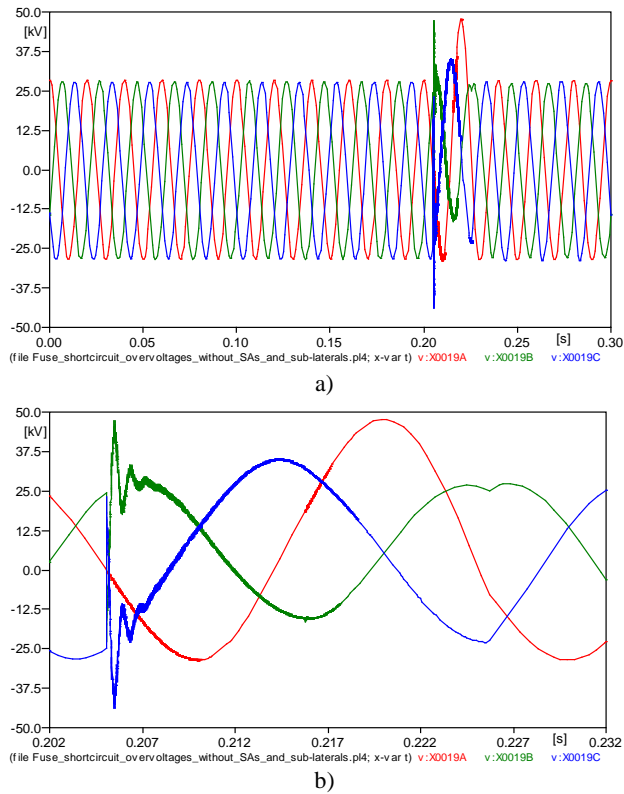

Fig. 4. Overvoltages at junction of overhead line and cable for scenario (a); the bottom figure is magnified version of top one

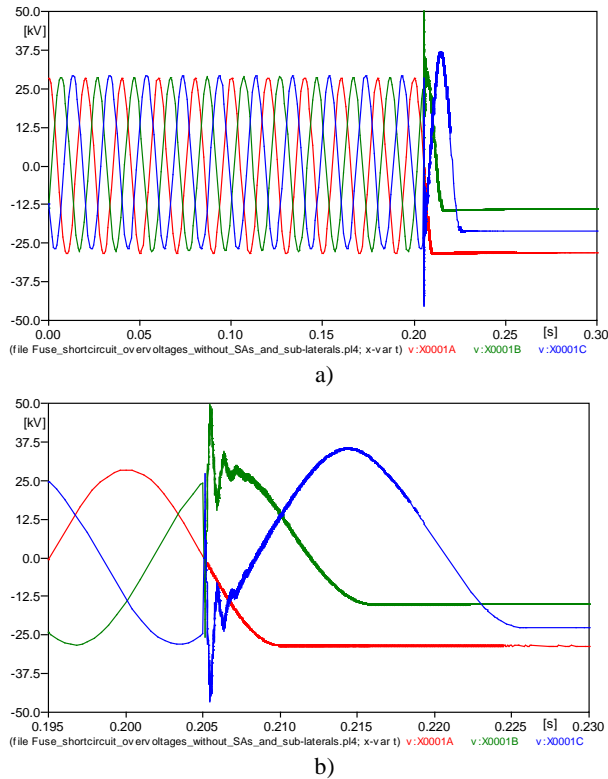

Fig. 5. Overvoltages at far end of cable near short-circuit point for scenario (a); the bottom figure is magnified version of top one

The overvoltages observed at junction the of overhead line and cable are shown in Fig. 7, the

overvoltages observed at 2 km away from surge arresters (almost same magnitude overvoltages are observed at 4 km) are shown in Fig. 8, and the overvoltages at the far end of cable near short-circuit point are shown in Fig. 9.

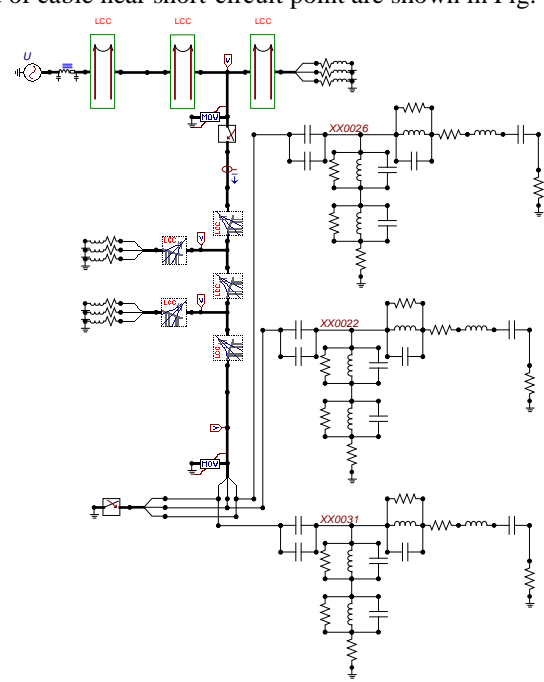

Fig. 6. ATP model of the MV network shown in Fig. 1 for scenario (d)

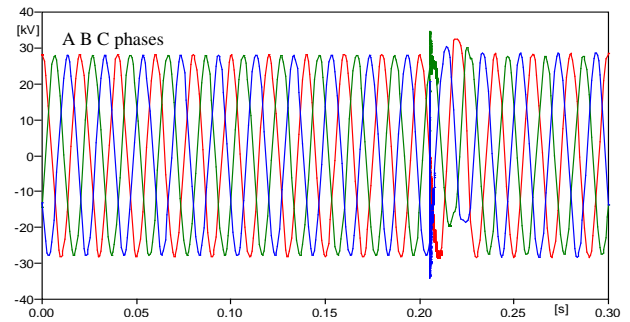

Fig. 7. Overvoltages at junction of overhead line and cable for scenario (d)

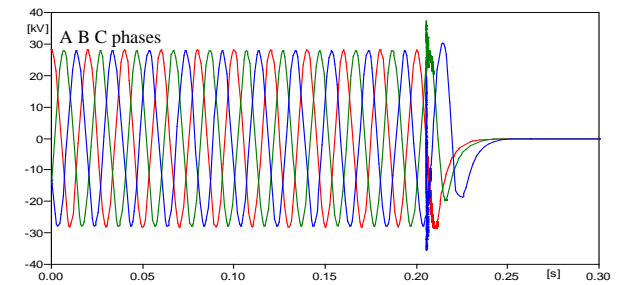

Fig. 8. Overvoltages at 2 km (almost same at 4 km) away from surge arrester (near fuse) for scenario (d)

If one surge arrester is installed on each side of the fuse, the overvoltages observed at the junction of overhead line a cable can be mitigated, however, overvoltages increases as we are going away at a point on the cable from the fuse (towards far end of the cable).

If one surge arrester is installed before the fuse, and the other is installed at the far end of the cable, the

overvoltages observed at the junction of overhead line and cable can be mitigated as well as the overvoltages magnitude is not very high as we are going away at a point on the cable from the fuse (near the cable end).

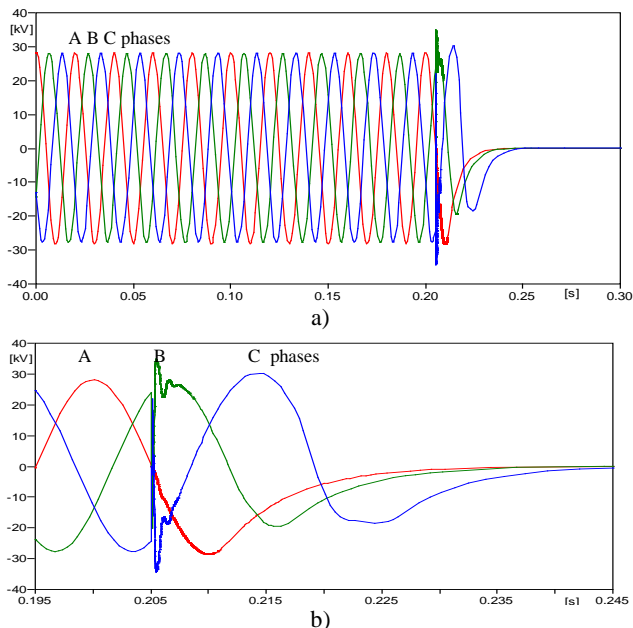

Fig. 9. Overvoltages at far end of cable near short-circuit point for scenario (d); the bottom figure is magnified version of top one

If one surge arrester is installed after the fuse, and the other is installed at the far end of the cable (near short-circuit), the overvoltages observed at the junction of overhead line and cable are bit higher as compared to previous scenario (d), however the overvoltages magnitude is not very high as we are going away at a point on the cable from the fuse (near the cable end).

Conclusions

Transient overvoltages are investigated and mitigated when a three-phase short-circuit occurs in cable lateral connected with MV overhead line and fuse is operated. The effect of sub-laterals is positive in this sense that overvoltages magnitude decreases with their presence. Keeping in view above results, it is concluded that the

optimal solution to reduce overvoltages due to short-circuits in cable is to install two surge arresters, one before the fuse near the junction of overhead line and power cable (i.e. SA-1) and other at the far end of the cable near the short-circuit point (i.e. SA-3). The investigations carried-out in this regard will be practically useful to design a protection scheme to mitigate the effect of transient overvoltages caused by short circuits and followed by the fuse operation in MV cable laterals connected with overhead lines.

References

1. **Sähköenergiالیitto ry ja Energia-alan keskusliitto ry.** Keskeytystilasto 2002 // Interruption statistics 2002. – Helsinki, – 2003. – 24 p.
2. **Heine P., Pohjanheimo P., Lehtonen M.** Measured Voltage Sag Distributions – Proc. 2003 // The 44th International Scientific Conference of Riga Technical University. – Riga, 2003. – Series 4. – Vol. 9. – P. 91-97.
3. **Heine P., Turunen J., Lehtonen M., Oikarinen A.** Measured Faults during Lightning Storms // IEEE PowerTech'2005. – St. Petersburg, 2005.
4. **Czapp S.** Protection Against Electric Shock Using Residual Current Devices in Circuits with Electronic Equipment // Electronics and Electrical Engineering. – Kaunas: Technologija, 2007. – No. 4(76). – P. 51–54.
5. Dimensioning, Testing and Application of Metal-oxide Surge Arresters in Medium Voltage networks. – Application Guidelines–Overvoltage Protection ABB. – CHHOS/AR 3257.99E (D), 1999. – 28 p.
6. **Gudžius S., Gvozdias V., Markevičius L. A., Morkvėnas A.** Real Time Monitoring of the State of Smart Grid // Electronics and Electrical Engineering. – Kaunas: Technologija, 2010. – No. 10(106). – P. 57–62.
7. **Vijayaraghavan G., Mark B., Malcolm B.** Practical Grounding, Bonding, Shielding and Surge Protection. – Perth, 2004. – 237 p.
8. **Sabiha N. A.** Lightning-induced Overvoltages in Medium Voltage Distribution Systems and Customers Experiences Voltage Spikes (Doctoral dissertation). – Aalto University, Espoo, Finland, 2010. – 199 p.
9. **Rafajdus P., Bracinić P., Hrabovcová V.** The Current Transformer Parameters Investigation and Simulations // Electronics and Electrical Engineering. – Kaunas: Technologija, 2010. – No. 4(100). – P. 29–32.

Received 2010 11 06

M. Hashmi, M. Lehtonen, S. Hänninen. Modelling and Analysis of Switching Overvoltages Caused by Short Circuits in MV Cables Connected with Overhead Lines // Electronics and Electrical Engineering. – Kaunas: Technologija, 2010. – No. 1(107). – P. 107–110.

In this paper, overvoltage transients are investigated and mitigated when a three-phase short-circuit occurs in cable lateral connected with medium voltage (MV) overhead line and fuse is operated. The transients are studied using EMTP-ATP simulation environment and the need of metal oxide varistors (MOVs) is investigated. The cable laterals consist of sub-laterals and their effect on reducing transients is also investigated. The surge arresters are installed at the junction of overhead line and cable and at far end of the cable near short-circuit point. The different mitigation methods are tested and optimal protection scheme to reduce overvoltages is proposed on the basis of surge arresters locations and sub-lateral connections. Ill. 9, bibl. 9 (in English; abstracts in English and Lithuanian).

M. Hashmi, M. Lehtonen, S. Hänninen. Komutacinių viršįtampių modeliavimas ir analizė šalinant trumpąjį jungimą, įvykusį vidutinės įtampos kabelinės linijos atšakoje, sujungtoje su oro linija // Elektronika ir elektrotechnika. – Kaunas: Technologija, 2010. – Nr. 1(107). – P. 107–110.

Aprašoms viršįtampių pereinamųjų procesų modeliavimas įvykus trifaziam trumpajam jungimui kabeliniame vidutinės įtampos orinio tinklo intarpe ir suveikus saugikliui. Pereinamieji procesai modeliuojami naudojant EMTP-ATP programų paketą, ir atliekamas metalo oksido varistorių charakteristikų tyrimas. Atliekant tyrimus buvo įvertinta kabelinių linijų parametru įtaka pereinamųjų procesų slopinimui tiriamajame tinkle. Viršįtampių iškrovikliai yra montuojami oro linijų ir kabelių sandūrose ir kabelinių linijų galuose. Išbandyti skirtingi linijų parametru įvertinimo algoritmai ir optimizuota apsaugos schema parenkant viršįtampių iškroviklių prijungimo vietas. Il. 9, bibl. 9 (anglų kalba; santraukos anglų ir lietuvių k.).

DOI: 10.5755/j02.eie.9102