

Informatical Model of the System of Automatic Breakdown Control in Energetic Systems

S. Bjelić

Faculty of Technical sciences Kosovska Mitrovica

K. Miloša Street No. 7, Kosovska Mitrovica, Serbia, phone: +381-63-8822492, e-mail: slobodan_bjelic@yahoo.com

U. Jakšić, N. Marković

Advanced Polytechnic School of Skilled Studies Zvečan

B. Nušića Street No. 6, Zvečan, Serbia, phone: +381-64-3360633, +381-63-189800, e-mails: uros_jaksic@yahoo.com, nen.mark@sezampro.rs

Introduction

Modern systems of dispatcher control (SDC) in management of energetic systems contain a large number of informatic subsystems with following tasks: a) automatic processing of operative and instructive information and b) providing of necessary information to dispatcher by automatic influence of the system or by defined call [1–6].

Informatical subsystem SDC informs the dispatcher about the work of whole energetic system or about some of its parts in normal regime, breakdown regime and regime of restauration (after the breakdown). Most often, the dispatcher receives information on operation of breakdown automatics of electric network 400 [kV] which has organizes central integral informatical system (CIIS). Information about the operation of separate devices of the system of automatic breakdown control and possible situation are submitted in CIIS by TT systems, and are processed in computer systems in the form that is suitable to dispatcher [7–9].

Given instruction must include advice to dispatcher for conversion of electrical network into complex situation and must be supported by documentation which is in nowadays mostly in electronic form. Informatical model of the system of automatic breakdown control (SABC) at 400 [kV] must also contain the data on influence of relay protection of separate parts of electric network. Set of information on operation of SABC of given network is submitted to dispatcher through subsystems of telemeasuring and tele signalling [10–16].

Informatical model must contain the following:

- 1) Influence of protective devices on elements of electric network;
- 2) Increase of voltage in distributing plants above the tolerable values;

3) Influence of system automatics sensitive to voltage increase;

4) Breakdown disconnection of separate parts of electric network and instruction for substitution of arranged values of the system of automatic control (SAC) in that situation;

5) Influence of SAC on forcing of device for transversal compensation (DTC);

6) Influence of SAC on discharging of transmission network;

7) Influence of SAC for break of asynchronous operation of the generator;

8) Influence of SAC on control of overload of DTC;

9) Influence of SAC for prevention of power increase in transmission network;

10) Influence of SAC against the frequency increase;

11) Influence of SAC of frequent drive of generator in hydroelectric power stations;

12) Origin of dangerous schemes for occurrence of dangerous conditions and pre-voltages on plant equipment;

13) Influence of device for automatic reconnection (ARC) of electric network parts;

14) Exceeding of tolerable values of active power on long-distance power lines.

Mathematical basis of informatical model is logic signal processing on:

– condition of breaker in electric networks (integral modelling of informatic logical structure of regime changes in electric network operation),

– influence of protective devices and SABC devices,

– exceeding of voltages and distribution of active power above tolerant values,

– quantity of distributed powers in previous regime.

In each of situation, on which occurrence dispatcher must be informed, must exist sufficient number of

information and analysed signals in the memory of the computer system. Informatical model should act automatically according to given priority in SDC. The simplified block of algorithm structures of informatical model, must follow the realization of sustained 14 parts of above given content.

Modelling of informatical logic structures induced by changes of operation regime of electric networks

Modern electric networks 400 [kV] with higher passing capacity, by the rule have system structure. Values in such networks are very high, for example, with respect to transferred power, so its stability is determined by the stability of network elements.

In such conditions break in energy transmission can have serious consequences, for example, like overload on one of parallel lines in the network, asynchronous operation, increase of frequency in local parts of energetic systems or connections, etc.

By studying of values of transferred electric energy on receiving and transmitting ends and branches which are connecting them, it is possible to create conditions for system automatics to preserve static and dynamic stability and appropriate levels of voltage and frequency.

For realization of these tasks algorithms and computer programs for controlling microprocessors (CM) must be created.

Without involving in the question of principle of usage of CM for analysis given transmission characteristics, here shall be considered structure of possible algorithm of intelligent model for energetic system control in example of electric network on Fig. 1. Elements 1–20 can influence the changes of transmission regime, and at the same time present integral components of system automatics. Arbitrary regime situation occurred in electric network on Fig. 1 can be presented by following logic operations:

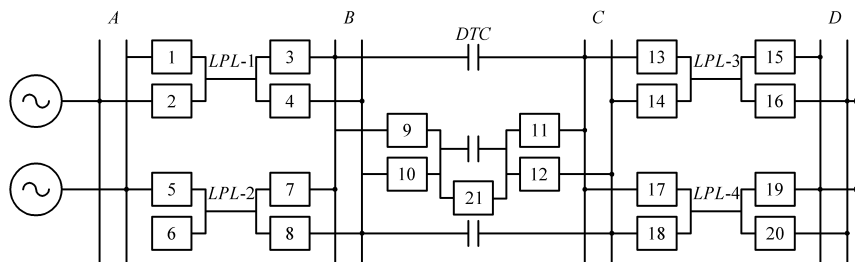

Fig. 1. Connections in energetic system

In order to minimal unit for information could be adaptable between energetic systems of neighbouring countries, certain regulation devices (RD), due to introduction into microprocessor sets, must be predicted.

The first assumption is that all necessary information on electric network operation is in the memory of informatical model of network (IMN). It is necessary to see how to mark that or some other situation during the change of electric network scheme. Solution should be sought through the logically defining of situation (LDS). In defining of LDS structure, it is necessary to determine logic functions that fit that given or some other structure of

1) Operation of reception of operative information, its processing and protocol in CIIS.

2) Operation of substitution in logic scheme and also change in regime of energy transmission on the basis of logic information analysis.

3) Estimation of values of possible power shortage and application of measures for compensation by control system in regime of breakdown (against breakdown automatics).

By informatical model of network mounted into memory are created possibilities for solving of this complex task for control of energetic system by intelligent model in normal regimes and breakdown regimes, possibility of realization of optimization tasks, etc.

For realization of task of stability preservation the informatical-logic algorithm with completely defined information is needed, and possible solution will be presented additionally.

First must be known data on generator nodes power, information on power flows trough parts of electric network, voltages on buses A, B, C, D (Fig. 1).

Second in a row are data on positions of all breakers (1-20). The whole set of data must be submitted to energetic system dispatcher centre. Because of that in energetic system is used modern coding and telesignalling in digital nine degrees dual-tens code.

Informatical model of network is conjugated with other blocks which are embodied in logic structure. Very important question that relates to IMN is question of mutual exchange of information from memory packages. In the phase of IMN creation, the following problems must also be solved:

- determination of information volume,
- their placement into appropriate memory packages,
- linking of cassettes with data on algorithm of logical determined situations, LDS and ALG KRS and other.

plugged electric network elements. Logical function for example $LPL1$ (long-distance power line 1), that relates to breakdown in transmission of power through power line is of form

$$\phi_1^{(DC)} = b_1 b_2 b_3 b_4 \vee \bar{b}_1 b_2 b_3 b_4 \vee b_1 \bar{b}_2 b_3 b_4, \quad (1)$$

where b – logical symbol of switch on position of breaker ($b = 1$ when breaker is switched on); \bar{b} – logical symbol of switch off position of breaker ($\bar{b} = 1$ when breaker is switched off); \vee – symbol of logic addition (linking/concordance); DC – disconnection.

In analogue way for all other long-distance power lines can be created logic functions $\phi_{LPL2}^{(dc)}, \phi_{LPL3}^{(dc)}, \phi_{LPL4}^{(dc)}$.

Logic function of device of transversal compensation (DTC) with disconnection of parallel branch is

$$\phi_{DTC}^{(par)} = \overline{b_9} \overline{b_{10}} \overline{b_{11}} \overline{b_{12}} \overline{b_{21}} \vee \overline{b_9} \overline{b_{10}} \overline{b_{11}} \overline{b_{12}} \overline{b_{21}} \vee \overline{b_9} \overline{b_{10}} \overline{b_{11}} \overline{b_{12}} \overline{b_{21}} \quad (2)$$

and for shunting (parallel connection) DTC is

$$\begin{aligned} \phi^{(sant)} &= \overline{b_9} \overline{b_{10}} \overline{b_{11}} \overline{b_{12}} \overline{b_{21}} \vee \overline{b_9} \overline{b_{10}} \overline{b_{11}} \overline{b_{12}} \overline{b_{21}} \vee \\ &\vee \overline{b_9} \overline{b_{10}} \overline{b_{11}} \overline{b_{12}} \overline{b_{21}} \vee \overline{b_9} \overline{b_{10}} \overline{b_{11}} \overline{b_{12}} \overline{b_{21}} \vee \\ &\vee \overline{b_9} \overline{b_{10}} \overline{b_{11}} \overline{b_{12}} \overline{b_{21}} \vee \overline{b_9} \overline{b_{10}} \overline{b_{11}} \overline{b_{12}} \overline{b_{21}} \vee \\ &\vee \overline{b_9} \overline{b_{10}} \overline{b_{11}} \overline{b_{12}} \overline{b_{21}} \vee \overline{b_9} \overline{b_{10}} \overline{b_{11}} \overline{b_{12}} \overline{b_{21}}. \end{aligned} \quad (3)$$

For each long-distance power line can be written a logic function that suits to normal regime of its operation; for example, for *LPL1*

$$\begin{aligned} \phi_{L1}^{(nor)} &= \overline{b_1} \overline{b_2} \overline{b_3} \overline{b_4} \vee \overline{b_1} \overline{b_2} \overline{b_3} \overline{b_4} \vee \overline{b_1} \overline{b_2} \overline{b_3} \overline{b_4} \vee \\ &\vee \overline{b_1} \overline{b_2} \overline{b_3} \overline{b_4} \vee \overline{b_1} \overline{b_2} \overline{b_3} \overline{b_4} \vee \overline{b_1} \overline{b_2} \overline{b_3} \overline{b_4} \vee \\ &\vee \overline{b_1} \overline{b_2} \overline{b_3} \overline{b_4} \vee \overline{b_1} \overline{b_2} \overline{b_3} \overline{b_4} \end{aligned} \quad (4)$$

Analogous can also be written for other *LPL*

$$\phi_{LPL2}^{(nor)} = \text{---}, \phi_{LPL3}^{(nor)} = \text{---}, \phi_{LPL4}^{(nor)} = \text{---} \quad (5)$$

and for normal operation regime of transversal compensation the following logic function

$$\begin{aligned} \phi_{DTC}^{(nor)} &= \overline{b_9} \overline{b_{10}} \overline{b_{11}} \overline{b_{12}} \overline{b_{21}} \vee \overline{b_9} \overline{b_{10}} \overline{b_{11}} \overline{b_{12}} \overline{b_{21}} \vee \\ &\vee \overline{b_9} \overline{b_{10}} \overline{b_{11}} \overline{b_{12}} \overline{b_{21}} \vee \overline{b_9} \overline{b_{10}} \overline{b_{11}} \overline{b_{12}} \overline{b_{21}} \vee \\ &\vee \overline{b_9} \overline{b_{10}} \overline{b_{11}} \overline{b_{12}} \overline{b_{21}} \vee \overline{b_9} \overline{b_{10}} \overline{b_{11}} \overline{b_{12}} \overline{b_{21}} \vee \\ &\vee \overline{b_9} \overline{b_{10}} \overline{b_{11}} \overline{b_{12}} \overline{b_{21}} \vee \overline{b_9} \overline{b_{10}} \overline{b_{11}} \overline{b_{12}} \overline{b_{21}} \vee \\ &\vee \overline{b_9} \overline{b_{10}} \overline{b_{11}} \overline{b_{12}} \overline{b_{21}}. \end{aligned} \quad (6)$$

If logic functions of normal operation regimes of separate long-distance power lines are known, then logical functions of normal regime that fits to schemes of the parts can be obtained, for example, *AB* and *CD*, namely:

$$\begin{cases} \phi_{AB}^{(nor)} = \phi_{LPL1}^{(nor)} \wedge \phi_{LPL2}^{(nor)}, \\ \phi_{CD}^{(nor)} = \phi_{LPL3}^{(nor)} \wedge \phi_{LPL4}^{(nor)}, \end{cases} \quad (7)$$

where \wedge – symbol of logic multiplication.

Normal operation regime of chosen model of electric network shall be completely determined by

$$\phi^{(nor)} = \phi_{AB}^{(nor)} \wedge \phi_{CD}^{(nor)} \wedge \phi_{DTC}^{(nor)}. \quad (8)$$

Disconnection of any part in the network model can be presented by following logic function:

$$\begin{cases} \phi_1^{(dc)} = \phi_{LPL1}^{(dc)} \wedge \phi_{LPL2}^{(nor)} \wedge \phi_{LPL3}^{(nor)} \wedge \phi_{LPL4}^{(nor)} \wedge \phi_{DTC}^{(nor)}, \\ \phi_2^{(dc)} = \phi_{LPL1}^{(nor)} \wedge \phi_{LPL2}^{(dc)} \wedge \phi_{LPL3}^{(nor)} \wedge \phi_{LPL4}^{(nor)} \wedge \phi_{DTC}^{(nor)}, \end{cases} \quad (9)$$

where $\phi_1^{(dis)}, \phi_2^{(dis)}$ – appropriate logic function of electric network in disconnection of only first, only second and only third, etc, long-distance power line.

Maintenance regimes that can occur in electric network model with the influence of forced transversal (parallel) compensation DTC, are presented by logic function:

$$\begin{cases} \phi_1^{(mai)} = \phi_{LPL1}^{(dc)} \wedge \phi_{LPL2}^{(nor)} \wedge \phi_{DTC}^{(par)} \wedge \phi_{LPL3}^{(dc)} \wedge \phi_{LPL4}^{(nor)}, \\ \phi_2^{(mai)} = \phi_{LPL1}^{(dc)} \wedge \phi_{LPL2}^{(nor)} \wedge \phi_{DTC}^{(par)} \wedge \phi_{LPL3}^{(nor)} \wedge \phi_{LPL4}^{(dc)}, \\ \phi_3^{(mai)} = \phi_{LPL1}^{(nor)} \wedge \phi_{LPL2}^{(dc)} \wedge \phi_{DTC}^{(par)} \wedge \phi_{LPL3}^{(dc)} \wedge \phi_{LPL4}^{(nor)}, \\ \phi_4^{(mai)} = \phi_{LPL1}^{(nor)} \wedge \phi_{LPL2}^{(dc)} \wedge \phi_{DTC}^{(par)} \wedge \phi_{LPL3}^{(nor)} \wedge \phi_{LPL4}^{(dc)}, \end{cases} \quad (10)$$

where $\phi_1^{(mai)}, \phi_2^{(mai)}, \phi_3^{(mai)}, \phi_4^{(mai)}$ – logic functions of disconnection of long-distance power lines due to maintenance according to following order: *LPL1*, then *LPL2*, *LPL3*, *LPL4*. In such way logic determination of situation comes to presentation of set of logic functions that presents any change of scheme (regime) of chosen model of electric network according to information of IMN that influence on all parts of informatical-logic algorithm.

Such influence provides following:

- Presentation on display of changes of regime situation in electric network (on Fig. 2 this is presented by broken line);

- Starting of appropriate algorithm that falls into algorithm complex of regime situation.

Since operation of algorithm requires current information on electric network (Fig. 2), it can be determined out of algorithm of complex of regime automatics (*AICRA*) and IMN.

Determination of situation set up by logic connection with *AICRA* (Fig. 2 *AICRA*) is defined in further situation of algorithms or arbitrary set of algorithms that accomplished together with *AICRS* (algorithm of complex of regime situation). In such way are also determined measures for influence in regimes of breakdowns (on Fig. 2 punctuate line on *AICRA*).

The purpose of forming of algorithm complex of regime situation is estimation of predominant differential stability values (normal and maintenance regimes) and values of needed power of long-distance power lines.

Illustrated complex presents a set of algorithms which number, in principle, should be equal to number of possible situation on electric network model.

For considered model (Fig. 1) can be assumed that *AICRS* is consisted of algorithms presented on Fig. 3,

(situation of breakdown on network parts and full break of power transmission and also short circuits have not been discussed).

In given complex are present algorithms of normal regimes which fit to complete schemes *AB* and *CD*. From those schemes can be seen that both algorithms have informatic connection with IMN, and act if are activated by their logic functions in certain situation.

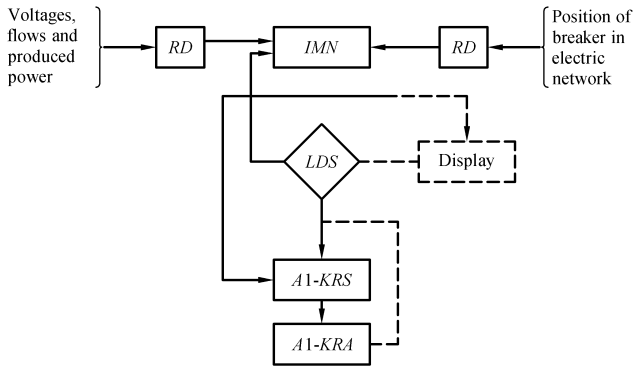

Fig. 2. Functional scheme of informatical-logic algorithm

For considered electric network model there are four cases of disconnection of long-distance power lines on different parts without full break of energy transmission, which is accomplished by algorithms *A1 LPL1-A1 DC LPL4*. Each algorithm of that or other long-distance power line *LPL1-LPL4* out of logic diagnostic is informational connected with IMN and is only initiated by its logic function. In maintenance regimes can occur four cases of disconnection of different long-distance power lines on two parts determined by appropriate algorithms:

(*A1 DC LPL1 LPL3*, *A1 DC LPL1 LPL4*, *A1 DC LPL2 LPL3* and *A1 DC LPL2 LPL4*).

It should be taken into account that each algorithm that falls into AL CRS is analogous to considered on Fig. 4, in which is the structure of algorithm of normal regime and disconnection of one long-distance power line on the part *AB* of network model. In illustrated structure is possible to see three types of informatic link. *A1 CRS* has informatical connection with IMN, logic with certain situation and controlling with algorithm complex of regime automatics.

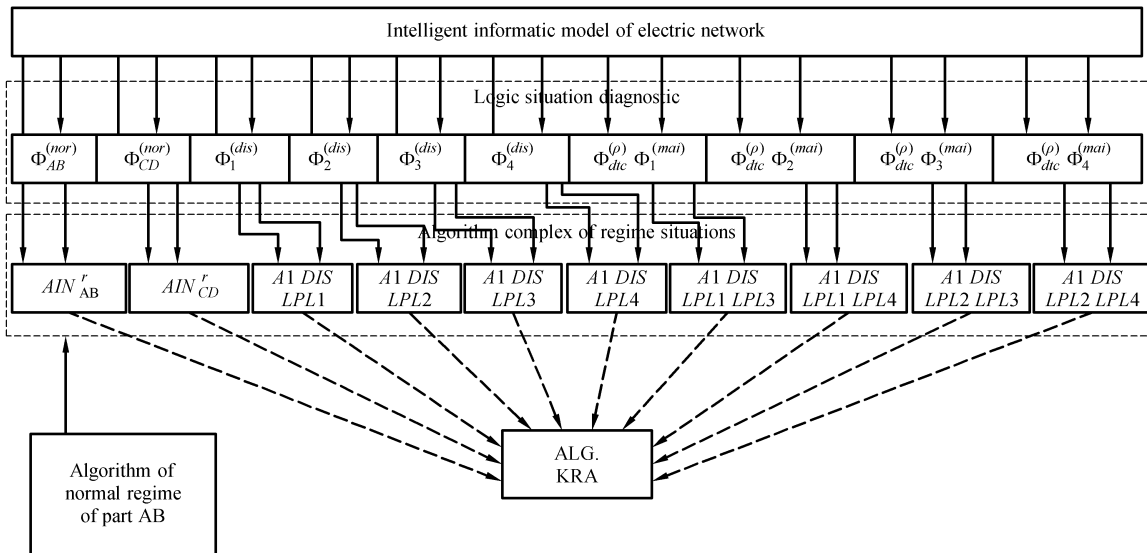

Fig. 3. Block of algorithm complex of regime situations

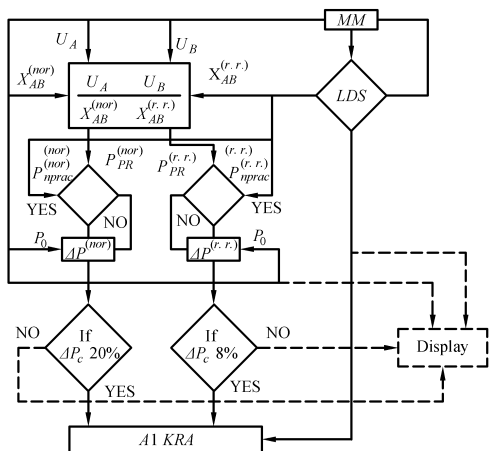

Fig. 4. Structure of algorithm of normal regime and disconnection of long-distance power line on parts *AB*

In reality, for each of them comes information directly from IMN on values of voltages on buses *A* and *B*, values on equivalent impedances of regime ($X_{AB}^{(nor)}$) and values of transferred power from both long-distance power lines P_0 . Information is introduced into appropriate operator and is presented on display.

Second type of connection dictates volume of information through logic diagnostic that shows regime changes on chosen model of electric network.

Along these connections are transmitted the values of equivalent impedances of maintenance regime (X_{AB}^{rr}) calculated values of predominant powers of normal and post-break (maintenance) regimes $P_{nprac}^{(nor)}$ and $P_{nprac}^{(r.r.)}$.

The third type of connection is intended to prepare influence of AI CRA and presentation of situation change on display. In the structure of both algorithms is operator whose purpose is calculation of factual predominant stability in normal post-break regime directly according to current information. After that, factual predominant stability is introduced into conditional operator, in which at the same time, through LDS is introduced the value of calculated predominant stability.

Calculated predominant stability is the value which is calculated according to certain computer program (it has been previously calculated and introduces into IMN). Conditional operator always at the input of next operator introduces the value: $P_{np}^{(nor)}$ or $P_{np}^{(r.r.)}$, if $P_{np}^{(nor)} \neq 0$, $P_{np}^{(r.r.)} \neq 0$.

In opposite case, in the next operator is introduced $P_{nprac}^{(nor)} = P_{nprac}^{(r.r.)}$

In the operator is estimated difference (ΔP) for normal as well as for post-break (maintenance) regimes through calculated values:

$$\begin{cases} \Delta P^{(nor)} = P_{np}^{(nor)} - P_0, \\ \Delta P^{(r.r.)} = P_{np}^{(r.r.)} - P_0, \end{cases} \quad (11)$$

where P_0 – value of required power transmitted via both long-distance power lines.

In the last conditional operator presented structure comes from comparison of values $\Delta P^{(nor)}$ and $\Delta P^{(r.r.)}$ (calculated in %) with standard value of 20% for normal and 8% for post-break regimes. If $\Delta P^{(nor)}$ and $\Delta P^{(r.r.)}$ exceed the coefficient values, dispatcher must be informed and in opposite case control is transferred to algorithm complex of regime automatics.

Conclusions

In the paper are presented separated parts of the structure of informatical-logic algorithm for changes of regime in chosen model of electric network. Such approach does not have feature of versatility, but presents modest contribution which shows possibilities of such model application in analysis on more basic examples. By improving the procedure complex models of network can also be solved, as well as the determination of their optimal structure.

In projecting and realisation of informatical model in energetic systems, there is a big problem in energetic systems in operation of secondary microprocessor systems in real time and in processing of huge quantity of informatic data. In such problems trivial solutions with series produced computers are not possible, so must be created microprocessor structures which have program and apparatus readiness for the purpose of creation of systems with high technical characteristics and insufficiently perfect data base. According to previous experience,

analyses of research results and overview of literature, the following important principles can be formulated:

- Apparatus/programme readiness predicts such organisation of secondary microprocessing systems that in a case of failure of apparatus/program support, obligations takes one of them or spare block. It is appropriate instead of term “failure” to use term “decrease/aggravation of quality”.

- Principle of multiprocessing that related to usage of homogenous microprocessors for realization of structure, because in this way is possible to use their mutual influence in the same memory base or by similar TT channels and commutating structures.

- Principle of modulation. This principle consists in independent influence of special one-type blocks-modules which can be replaced at any moment. This increases maintenance capability and reliability, concerning the possibility of replacement of defective modules with spare one. Modulation of program protection is achieved by separation of program modules which are invariant regarding their position in the memory of calculating machine.

- Principle of functional decentralisation regards to division of functional tasks between processing systems, by which their parallelism in operation in real time is achieved. In that way in some processors can be increased speed of influence and contracted the quantity of tasks.

- Principle of unique data base characterises the system approach in information processing which leads to permanent increase and rehabilitation of data needed for system functioning. Identical information processed in different calculating modules, are introduced into system along the same channel, which simplifies transmission ways from primary (energetic systems) towards secondary (SAC) systems.

Previously mentioned principles determine functional solutions and characteristics of the system. However, in creation of integral models and management of energetic systems computer complexes are needed, for which realization must be introduced principles that lead to simplification of process of elaboration, correction, adjustment and development. Those additional principles are:

- Principle of complex projecting method. This principle could be applied on creation of secondary microprocessing system in the form of unique complex (states-Serbia and of West Balkans), which would be used for solving of secondary systems tasks of energetic facilities. In that case concrete equipment is not considered autonomously, but as an element (subsystem) of complex SAC.

- Principle of continuous development of the system considers possibility of system structure change, increase of number of modules and function and modification of program support. This relates not only to easy change of program and subprogram, but also to criterion according to which tasks are set.

- Principle of defining of new tasks predicts new complements in the algorithm system in accordance with new needs provided by computer technology and in that

way is achieved increase of level of technical improvement to scientific- researching level.

Informatical model with the application of microprocessing systems comprises methods and procedures of operation with information which came into system from facility and preparation of this information for utilisation (processing), storage and exchange towards external systems.

It is known that primary information is also called the data and that term comprises acquired knowledge on controlled facility and is expressed in the form of numbers, letters or special symbols. Analogue values (current, voltage) and direct values (condition of commuting equipment in every aspect) fall under those data in energetic system.

Volume and frequency of data transmission are determined by algorithms realized by secondary systems. Primary information also comprises the instructions given in the case of operation regime changes in the system as well as during the time of system testing.

References

1. **Anthony A. M.** Electric Power System Protection and Coordination. – New York: McGraw/Hill Incorporation, 1995.
2. **Padhke A. A. & Thorpe S. J.** Computer Relayng power System. – England, Tautoon, Somerset Research Studies Press LTD, New York, Chichester, Toronto, Singapoor, 1998.
3. **Jakšić U., Marković N., Bjelić S.** Inertia (slowness) of Zero Order Components Filter // Electronics and Electrical Engineering. – Kaunas: Technologija, 2009. – No. 6(94). – P. 99–105.
4. **Marković N., Jakšić U., Bjelić S., Vujičić M.** Development of New Measuring Systems Based on Symmetric Components in Electric Networks // Electronics and Electrical Engineering. – Kaunas: Technologija, 2010. – No. 8(104). – P. 57–62.
5. **Arrillaga J., Arnold C. P., Harker B. J.** Computer Modeling of Electrical Power Systems. – New York: John Wiley&Sons, Inc., 1986.
6. **Bjelić S., Popović G.** Flexibility Equipment of Protection, Control and Measure for Mean and Low Electrical Network in Power Transformation Substations // Electronics and Electrical Engineering. – Kaunas: Technologija, 2009. – No. 4(92). – P. 27–32.
7. **Angrisani L., Daponte P., D'Apuzzo M., Testa A.** A measurement method based on the wavelet transform for power quality analysis // IEEE Trans. Power Delivery, 1998. – Vol. 13. – No. 4. – P. 990–998.
8. **Zheng T., Makram E. B.** Wavelet representation of voltage flicker // Electric Power Systems Research, 1998. – Vol. 48. – No. 2. – P. 133–140.
9. **Zhao W., Song Y. H. & Min Y.** Wavelet analysis based scheme for fault detection and classification in underground power cable systems // Electric Power Systems Research, 2000. – Vol. 53. – No. 1. – P. 23–30.
10. **Arrillaga J., Watson N. R., Chen S.** Power System Quality Assessment. – Chichester, John Wiley, 2000.
11. **Bjelić S.** Energy management system in Electrical Power System // Proceedings of International SAUM Conference, Kragujevac University, 1997. – P. 428–438.
12. **Jakšić U., Bjelić S.** New Zero-Sequence Directional Transverse Differential Protection, //Facta Universitatis-Series Electronics and Energetics emphasizes publishing, 2004.
13. **Jakšić U., Mladenović V., Bjelić S.** The voltage dependence of control symmetrical components of the output of the distant current'sonde // The Fifteenth National Scientific Conference Electronics. – Sozopol BG, 2006. – P 3–17.
14. **Bjelić S., Jakšić U.** Measuring uncertainties of programmable distant measuring element // Collection oF VTS Pozarevac 1–2/2006. – P. 130–135.
15. **Bjelić S., Jakšić U.** Measuring of nonsymmetrical components in power energy network // The IASTED International Conference on Power Energy and Aplication (PAE). – University George Anderson, Gaborone, 2006. – ID. #506–47.
16. **Bjelić S., Jakšić U., Marković N.** Devices with symmetric components for reduction of asymmetry of phase voltages in low-voltage electric networks // Scientific manifestation (OSCP) in scientific magazine Agricultural technique, 2008. – No. 4. – P. 9–17.

Received 2010 02 10

S. Bjelić, U. Jakšić, N. Marković. Informatical Model of the System of Automatic Breakdown Control in Energetic Systems // Electronics and Electrical Engineering. – Kaunas: Technologija, 2010. – No. 1(107). – P. 87–92.

In this paper is presented informatical dynamic model and method for accurate defining of algorithm of distribution of functional tasks in microprocessors for control of protective system. Functional features of alternative microprocessor protective system are examined in accordance with the purpose and conditions of exploitation. Ill. 4, bibl. 16 (in English; abstracts in English and Lithuanian).

S. Bjelić, U. Jakšić, N. Marković. Sistemos informacinis modelis energetinėje automatinųjų gedimų kontrolės sistemoje // Elektronika ir elektrotechnika. – Kaunas: Technologija, 2010. – Nr. 1(107). – P. 87–92.

Pateiktas funkcinių užduočių paskirstymo mikroprocesoriuose informacinis dinaminis modelis ir tikslaus apibrėžimo algoritmo metodas. Alternatyvių mikroprocesorių funkcinės galimybės išnagrinėtos įvertinant paskirtį ir naudojimo sąlygas. Il. 4, bibl. 16 (anglų kalba; santraukos anglų ir lietuvių k.).

DOI: 10.5755/j02.eie.9094