

Multi-Agent Based E-Social Care Support System for Inhabitancies of a Smart Eco-Social Apartment

A. A. Bielskis

*Department of Informatics, University of Klaipėda,
Manto str. 84, LT-92294 Klaipėda, Lithuania, e-mail: bielskis@ik.ku.lt
Department of Electrical Engineering, University of Klaipėda*

A. Andziulis, O. Ramašauskas

*Department of Informatics, University of Klaipėda,
Manto str. 84, LT-92294 Klaipėda, Lithuania, e-mails: arunas@ik.ku.lt, olegas@ik.ku.lt*

E. Guseinoviė

*Department of Electrical Engineering, University of Klaipėda,
e-mail: guseinoviene@gmail.com*

D. Dzemydienė

*Department of Informatics and Software Systems, Mykolas Romeris University,
Ateities 20, Vilnius, LT-08303, Lithuania, e-mail: daledz@mruni.lt*

G. Gricius

*Department of Informatics, University of Klaipėda,
Manto str. 84, LT-92294 Klaipėda, Lithuania, e-mail: gediminas@ik.ku.lt,
Institute of Mathematics and Informatics, Vilnius University,
Akademijos str. 4, Vilnius, LT-08663, Lithuania*

Introduction

The Smart Ecological and Social Apartments (SESA) are understood nowadays as living and working environment with equipment friendly working for the people and the nature of the environment. The SESA is capable to adaptively gain its experience to: a) minimize the amount and loss of heat and electrical power acquired from central heat and electrical support systems; b) make the most efficient use of own alternative energy; c) provide of e-consulting services on e-health and e-social care aspects for the inhabitancies of given SESA; d) help people to participating in the process of development of the concept of SESA. Principles of creating of subsystem of adaptive user-friendly e-health care service for people with movement disabilities are described in [1–3]. The model of a few adaptive moving wheelchair-type robots was recently proposed in [4–6] to servicing people with movement disabilities in a SESA. This paper presents principles of implementation of the model of multi-agent based e-social care support system by using of an intelligent power controller. The proposed multi-agent based system is planned to be used for an adaptive dimming of LED lighting and providing of power supply for motors

as an appropriate e-social care support for people in the SESA.

Designing of an Intelligent Power Controller

The Intelligent Power Controllers are planned to be used to controlling of power delivered from heat pumps, solar radiation subsystem, wind turbine, and solar batteries installed into the SESA as it is shown in the block diagram of Fig.1. An Intelligent Power Controller, the IPC is composed of two modules shown in Fig.2 and Fig.3. Fig.2 gives a schematic diagram of Atmega32 based microcontroller as well as of block diagram of subsystem for measurements of electro dermal activity, the EDA, heart rate, the HR, and finger temperature, the FT of the inhabitancies in the SESA.

Fig.3 presents an approach of a smart socket for an adaptive dimming of lighting as well as for the control of speed and power of asynchronous motors of heat pumps in the SESA by using BUZ41A power MOSFET, BT137/600 and BT136/500 triac type symmetrical thyristors accordingly. MOC3022 and 4N35 general purpose phototransistor optocouplers are used for isolation. Each IPC contains a module for measuring of emotional state of person in the SESA by using INA126 instrumentation

amplifier for electro dermal activity (EDA) measurement, by using TCRT1010 optocoupler for measurement of heart rate (HR) as well as by using temperature sensor LM35DZ for measurements of finger temperature (FT) of given person in the SESA.

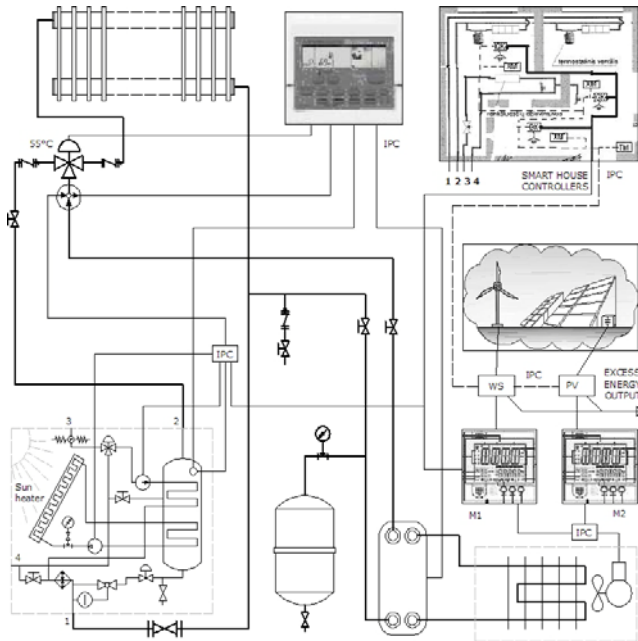

Fig. 1. Block diagram of installation of a set of the Intelligent Power Controllers to controlling of power delivered from the following subsystems installed into the SESA: heat pump, solar radiation subsystem, wind turbine, and solar batteries

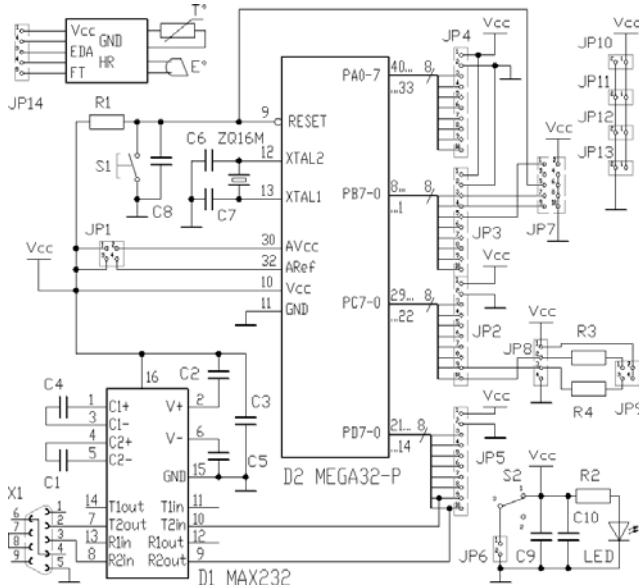

Fig. 2. Atmega32 based microcontroller used for intelligent power control as well as of measurements of EDA, HR, and FT of the inhabitants in the SESA

The power consuming is calculated in the model of Fig. 3 by multiplying the measured values of voltage U_T and the current I_T , taken from the mains via current transformers. The following dynamic equilibrium equations are used to calculating of mains current I_T , load current I_R , and secondary current of current transformer I_{T2} :

$$\begin{cases} R_{var} = \infty, I_T = I_{11}, I_R = I_{22}, I_{T2} = I_{33}, \\ I_{11}(r+1/sC_7) + I_{22}(-1/sC_7) + I_{33}(0) = U_T, \\ I_{11}(-1/sC_7) + I_{22}(1/sC_7 + sL_1 + R) + I_{33}(-sM) = 0, \\ I_{11}(0) + I_{22}(-sM) + I_{33}(sL_2 + R_1 + R_{AD} / (sR_{AD}C_1 + 1)) = 0. \end{cases} \quad (1)$$

Measuring circuit of the voltage U_{R8} which is proportional to RMS value of the mains voltage U_T :

$$\begin{aligned} I_{T1}(rT_1 + sL_{T1}) + I_{T2}(-sM) &= U_T, \\ I_{T1}(-sM) + I_{T2}(r_{T2} + sL_{T2} + (R_7 + R_8)/(1 + (R_7 + R_8)sC_1)) &= 0 \end{aligned} \quad (2)$$

The moment value of full power $S(kT)$ in Volt-Amperes delivered into the load by the smart socket is calculated as a product $U_i(kT) * U_{R8}(kT) * K_i * K_u$. The values of $U_i(kT)$ and $U_{R8}(kT)$, measured and applied for an analogue to digital conversion through the ADC0 and ADC1 channels of ATmega32 microcontroller, may be calculated by the following expressions:

For the case of real eigenvalues:

$$U_{R8}(kT) = U_{R8}(D_{U1} \exp(q_{1u}k) + D_{U2} \exp(q_{2u}k) + D_{U3} \exp(q_{3u}k)), \quad (3)$$

$$U_i(kT) = U_i(D_{i1} \exp(q_{1i}k) + D_{i2} \exp(q_{2i}k) + D_{i3} \exp(q_{3i}k) + D_{i4} \exp(q_{4i}k)). \quad (4)$$

For the case of complex eigenvalues:

$$U_{R8}(kT) = U_{R8}(D_{U1} \exp(q_{1u}k) + D_{U2} \exp(q_{2u}k) + D_{U3} \exp(q_{3u}k)), \quad (5)$$

$$U_i(kT) = U_i(D_{i1k} \exp(q_{1ik}k) + D_{i2k} \exp(q_{2ik}k) + D_{i34k} \exp(-T \delta k) \sin(kT \omega_1 + \phi_{34})), \quad (6)$$

where $\delta_1 = r_{T1}/L_{T1}$, $2\delta_2 = 1/(C_1(R_7 + R_8)) + r_{T2}/L_{T2}$, $\omega_{02}^2 = r_{T2}^2/(L_{T2}^2 C_1(R_7 + R_8))$, $2\delta_M = 1/(R_{AD}C_1) + R_1/L_2$, $\omega_{0M}^2 = R_1/L_2 R_{AD}C_1$, $2\delta = r/L_1 + 1/RC_7$, $\omega_0^2 = (r + R)/(L_1 C_7 r)$. $Ts_{1u} = q_{1u} = -T \delta_1 = -(T r_{T1}/L_{T1})$, $Ts_{2u} = q_{2u} = T(-\delta_2 + \omega_2)$, $Ts_{3u} = q_{3u} = T(-\delta_2 - \omega_2)$, $D_{U1} = 1/(s_{1u}^2 + 2\delta_2 s_{1u} + \omega_{02}^2)$, $D_{U2} = 1/(2(s_{2u} - s_{1u})(s_{2u} + \delta_2))$, $D_{U3} = 1/(2(s_{3u} - s_{1u})(s_{3u} + \delta_2))$, $s_{1i} = q_{1i}/T = -\delta_M + \omega_{1M}$, $s_{2i} = q_{2i}/T = -\delta_M - \omega_{1M}$, $s_{3i} = q_{3i}/T = -\delta + \omega_3$, $s_{4i} = q_{4i}/T = -\delta - \omega_3$, $D_{i1} = 1/(2(s_{1i} + \delta_M)(s_{1i}^2 + 2\delta s_{1i} + \omega_0^2))$; $D_{i2} = 1/(2(s_{2i} + \delta_M)(s_{2i}^2 + 2\delta s_{2i} + \omega_0^2))$; $D_{i3} = 1/(2(s_{3i}^2 + 2\delta_M s_{3i} + \omega_{0M}^2)(s_{3i} + \delta))$; $D_{i4} = 1/(2(s_{4i}^2 + 2\delta_M s_{4i} + \omega_{0M}^2)(s_{4i} + \delta))$; $q_{1ki} = T s_{1i}$; $q_{2ki} = T s_{2i}$; $D_{i1k} = D_{i1}$; $D_{i2k} = D_{i2}$; $D_{i34k} = 1/\sqrt{A_{34}^2 + B_{34}^2}$; $A_{34} = \delta^2 - \omega_1^2 - 2\delta \delta_M + \omega_{0M}^2$; $B_{34} = 2\omega_1(\delta_M - \delta)$; $\omega_1 = \sqrt{(\omega_0^2 - \delta^2)}$; $\phi_{34} = \text{atan}(B_{34}/A_{34})$; $K_i = I_{TRMS}/U_{iRMS}$; $K_u = U_{TRMS}/U_{R8RMS}$, T – sampling period in ms.

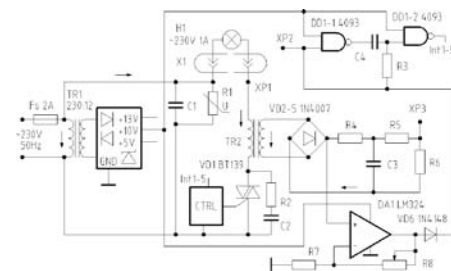

Fig. 3. Schematic diagram of an intelligent power controller to provide of adaptive control of motors and LED lights used to servicing people in the SESA

Designing of multi-agent based e-social care system

The proposed multi-agent system of Fig. 4 consists of two main parts, first part – for human’s physiological data collection, analysis and emotional state detection and another part – for an intelligent power control which takes environmental and hardware parameters and, with the use of embedded agents, provides adaptive control of LED lights, temperature as well as of power consuming by motors used in the SESA. These two parts are linked with one common event, the *NewUserCondition*, which can indicate how users’ emotional condition changes after intelligent power control system have changed light intensity, temperature or other environmental parameters, and then it will try to adopt these parameters to the given user. The first group of agents permanently performs the following actions:

"PhysiologicalParametersAnalytic" agent is responsible for communication between hardware and software, analyzing collected physiological data and emotional state detection. It takes data via RS232 protocol, determines the type of received data (HR, EDA, temperature, and settings information) and performs appropriate actions. This agent is also responsible for the feedback to the hardware (LCD information transfer, ADC channels settings transfer, etc.).

Upon receiving of new data, the agent identifies data and distinguishes new physiological parameters or device settings. On receiving the new physiological parameters, agent stores them in the global database called *UserPhysiologicalData* and also generates events *NewECGSample*, *NewEDASample*, and *NewSTSample* to the other agents. In a case on receiving new hardware parameters, it will execute the plan *pNewSettings* which will update the software settings, and report to the hardware information about the changes. The agent saves all received data to the database and also receives information from the agent "UserInteraction" on what should be displayed on the LCD display. The agent sends information to the hardware via event *UpdateDevice*.

The agent "RStatistic" is responsible for communication between whole multi-agent software and R statistical tool in which Nadaraya-Watson kernel regression smoothing, Fourier transform, self-organizing maps and other complex algorithms are provided.

"UserInterface" – the agent is responsible for information conveying to the user and the users commands input. The agent has an internal database of *Suggestions* which holds the tips to the user, such as what user should do or what action should be taken by a change of emotional state. This agent prints the HR, EDA, and FT graphs on the screen. After receiving notice of the new emotional state, it shows the graphs on the screen and tries to find the appropriate advice to the user in the database *Suggestions*. User information is also sent to the hardware to be printed in the LCD screen. The agent adds all the data to the web server via plan *AddToWebInterface* which uses TCP/IP protocol for data transmission. The agent takes the event *NewUsersCondition* with detected emotional state, and also physiological data from the global database *UserPhysiologicalData*. It performs data smoothing and displays it on the screen. After receiving information about new human physiological state by using event

NewUsersCondition, it decides whether to provide the user with any proposal. If it decides to provide then the proposal is selected from the database *Suggestions* and displayed on the screen, and also it is transmitted to the users LCD. It is also the agent that takes the user commands via web interface and, by the user desire, creates a dynamical agent "Driver" which will have information about location to which the user wants to go. Agent "Driver" has an internal database *HomeLayout* which has schemes of the house layouts, and, according to the data, the agent creates a scenario by which the user is moved to the desired location. During the journey, where the way meets an obstacle or home layout has been changed, the agent updates the database *HomeLayout* data. After completing a journey, agent "Driver" retains the accumulated data.

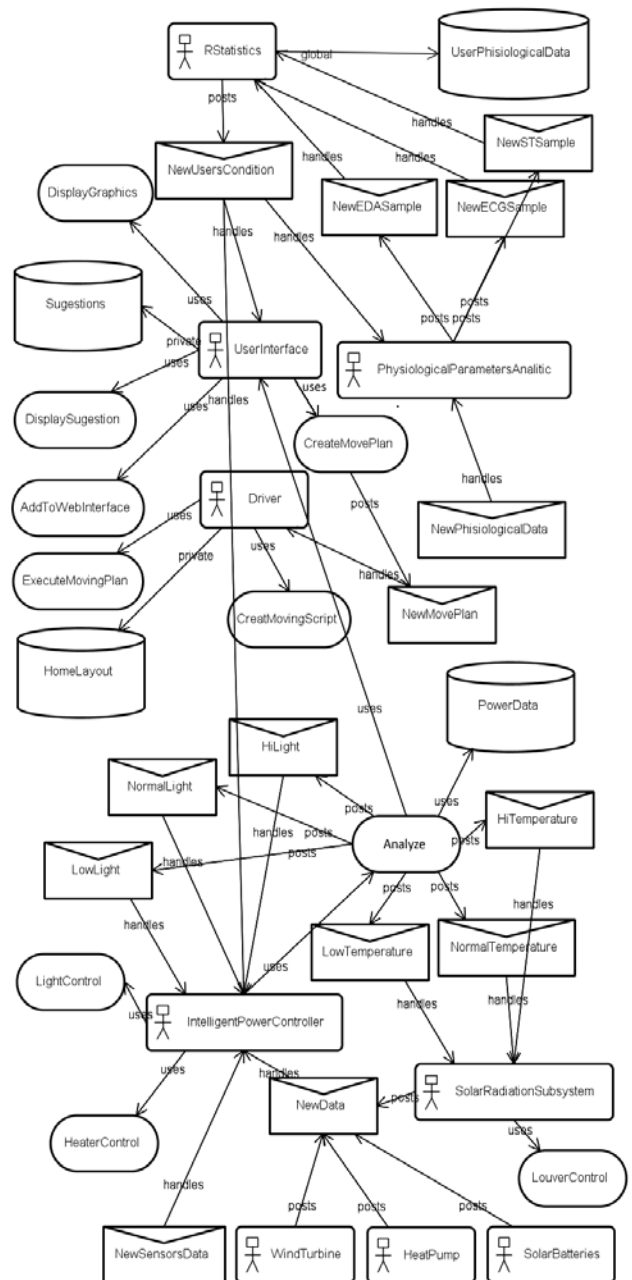

Fig. 4. Multi-agent-based system: human-computer remote interaction block diagram

Other part of the agents, the agents *SolarRadiationSubsystem*, *WindTurbine*, *HeatPump*, *SolarBatteries*, and *IntelligentPowerControl* are responsible for environment monitoring and intelligent power control. The main agent of this part is “*IntelligentPowerControl*”. It handles events from the hardware sensors via event *NewSensorsData* (temperature, LED light level, humidity) and performs plan *Analyze* which is capable to create events: *LowTemperature*, *NormalTemperature*, *LowLight*, *HiTemperature*, *NormalLight*, and *HiLight*. After receiving these events, an agent “*IntelligentPowerControl*” executes plans *LightControl*, *HeaterControl* that triggers embedded agents responsible for light, heater, fan and other devices control. All data received from sensors as well as the agents of part 2 are stored in database *PowerData*.

Conclusions

The paper presents further development steps of recently proposed model of an adaptive multi-agent-based e-health and e-social care system by introducing in it an intelligent power controller to supporting people in a Smart Ecological and Social Apartment, the SESA. The schematic diagrams of the controller are proposed for adaptive control of motors and LED lights as well as for measurements of EDA, HR, and FT signals of inhabitants in the SESA. The proposed in this paper multi-agent system consists of two groups of agents, first, the agents for human’s physiological data collection, analysis and emotional state detection, and, second, the agents for an intelligent power control which takes environmental and hardware parameters and, with the use of embedded agents, provides adaptive control of LED lights, temperature as well as of power consuming by motors used in the SESA.

Acknowledgement

The authors thank the Project “LLII-061 Development of Joint Research and Training Centre in High Technology

Area” (Latvia-Lithuania Cross Border Cooperation Programme Under European Territorial Cooperation Objective 2007-2013 Subsidy Contract No: LV_LT/1.1./LLII-061/2010/) as well as the Project “LED-Increasing Energy Saving through Conversion to LED lighting in public space” within the South Baltic Cross-Border Co-operation Programme 2007-2013, Subsidy contract No: WTPB.02.02.00-94-001/09-00) for the possibility to complete a scientific research.

References

1. **Pentland A.** Healthwear: Medical Technology Becomes Wearable// IEEE Computer, May 2004. – No. 37(5). – P. 42–49.
2. **Villon O., Lisett Ch.** A User–Modeling Approach to Build User’s Psycho–Physiological Maps of Emotions using Bio–Sensors // Proc. of IEEE Roman, 2006. – P. 269–276.
3. **Bielskis A. A., Dzemydienė D., Denisov V., Andziulis A., Drungilas D.** An approach of multi–agent control of bio–robots using intelligent recognition diagnosis of persons with moving disabilities // Technological and Economic Development of Economy. – Vilnius: Technika, 2009. – Vol. 15. – No. 3. – P. 377–394.
4. **Andziulis A., Bielskis A. A., Denisovas V., Ramašauskas O., Bielskienė J., Bielskis P., Guseinovicė E.** An Approach of Creating of an Intelligent Mobile Tutoring Eco–social Laboratory for Assisted Recreation // Electronics and Electrical Engineering. – Kaunas: Technologija, 2009. – No. 3(91). – P. 61–66.
5. **Bielskis A. A., V. Denisovas V., Drungilas D., Gričius G., Ramašauskas O.** Modeling of Intelligent Multi–Agent based E–health Care System for People with Movement Disabilities // Electronics and Electrical Engineering. – Kaunas: Technologija, 2008. – No. 6(86). – P. 37–42.
6. **Bielskis A. A., Grecevičius P., Ramašauskas O.** Development of an intelligent eco–social environment for assisted living // Vadyba. – Klaipėda: Klaipėda University Publishing, 2009. – No.1 (14). – P. 89–98.

Received 2010 11 22

A. A. Bielskis, A. Andziulis, O. Ramašauskas, E. Guseinovicė, D. Dzemydienė, G. Gričius. Multi-Agent Based E-Social Care Support System for Inhabitancies of a Smart Eco-Social Apartment // Electronics and Electrical Engineering. – Kaunas: Technologija, 2011. – No. 1(107). – P. 11–14.

The paper presents further development steps of recently proposed model of an adaptive multi-agent-based e-social care system by introducing in it an intelligent power controller to supporting people in a Smart Ecological and Social Apartment, the SESA. The schematic diagrams of the controller are proposed for adaptive control of motors and LED lights as well as for measurements of EDA, HR, and FT signals of inhabitants in the SESA. The proposed in this paper multi-agent system consists of two groups of agents, first, the agents for human’s physiological data collection, analysis and emotional state detection, and, second, the agents for an intelligent power control which takes environmental and hardware parameters and, with the use of embedded agents, provides adaptive control of LED lights, temperature as well as of power consuming by motors used in the SESA in accordance with the human state defined by the first group of agents. Ill. 4, bibl. 6 (in English; abstracts in English and Lithuanian).

A. A. Bielskis, A. Andziulis, O. Ramašauskas, E. Guseinovicė, D. Dzemydienė, G. Gričius. Daugelio agentų e. socialinės rūpybos paslaugų sistema išmaniojo ekologiško socialinio būsto gyventojams // Elektronika ir elektrotechnika. – Kaunas: Technologija, 2011. – Nr. 1(107). – P. 11–14.

Autorių siūlomas intelektualios agentinės sistemos modelis e. socialinės rūpybos paslaugoms teikti išmaniajame ekologiškame socialiajame būste (IESB) įgalina adaptyviai valdyti šviesos diodų (LED) apšvietimo intensyvumą ir spalvą bei IESB esančių variklių galią, taip pat vykdyti IESB gyventojų odos elektrinio aktyvumo (EDA), širdies ritmo (HR) ir pirštų temperatūros (FT) kitimo parametrų matavimus, panaudojant išmanųjį galios keitiklį (IGK). Darbe pasiūlytąjį daugiaagentų modelį sudaro dvi agentų grupės: pirmoji – IESB gyventojų fiziologiniams duomenims rinkti, analizuoti ir jų emociinei būsenai nustatyti, o antroji – intelektualiam galios paskirstymui LED apšvietimui ir IESB esančių variklių valdymui pagal realiu laiku išmatuotą IESB gyventojų fiziologinę būseną. Il. 4, bibl. 6 (anglų kalba; santraukos anglų ir lietuvių k.).

DOI: 10.5755/j02.eie.9070