

Thermal Modelling and Design of On-board DC-DC Power Converter using Finite Element Method

Z. Staliulionis¹, Z. Zhang², R. Pittini², M. A. E. Andersen², A. Noreika³, P. Tarvydas³

¹*Department of Mechanical engineering, Technical University of Denmark, Kgs. Lyngby, DK-2800, Denmark*

²*Department of Electrical Engineering, Technical University of Denmark, Kgs. Lyngby, DK-2800, Denmark*

³*Department of Electronics Engineering, Kaunas University of Technology, Studentu St. 50, LT-51368 Kaunas, Lithuania*

Abstract—Power electronic converters are widely used and play a pivotal role in electronics area. The temperature causes around 54 % of all power converters failures. Thermal loads are nowadays one of the bottlenecks in the power system design and the cooling efficiency of a system is primarily determined by numerical modelling techniques. Therefore, thermal design through thermal modelling and simulation is becoming an integral part of the design process as less expensive compared to the experimental cut-and-try approach. Here the investigation is performed using finite element method-based modelling, and also the potential of such analysis was demonstrated by real-world measurements and comparison of obtained results. Thermal modelling was accomplished using finite element analysis software COMSOL and thermo-imaging camera was used to measure the thermal field distribution. Also, the improved configuration of power converter was proposed.

Index Terms—Power electronic converters, temperature measurement, thermal modelling, finite element method.

I. INTRODUCTION

This paper discusses about thermal design of boost isolated DC-DC converter. The thermal design was accomplished in order to evaluate the accuracy of the simplified power converter model compared to temperature measurement readings. To model the thermal distribution of power converter, it is very important to have a reasonable power converter model. Then, such modelling principles of power converter can be used for any type of power converter thermal investigation and design. Therefore, the temperature measurements of power converter were done which define the operating condition of power converter and helps to create a substantiated thermal model. Also, the power losses were estimated in order to have actual results for thermal modelling [1]. Then, this paper discusses the creation of the simplified component models which can be used to perform a thermal design of the whole power as a system of interacting components. Finally, the power converter thermal design results are compared with actual temperature

readings.

II. TEMPERATURE MEASUREMENTS OF FULL BRIDGE BOOST ISOLATED POWER CONVERTER

For investigation purposes, the Full-bridge boost isolated power converter was used which is shown in Fig. 1. The converter mainly consists of the transformer, four transistors (TO-220), four diodes (TO-220), inductor, three output capacitors and two input capacitors.

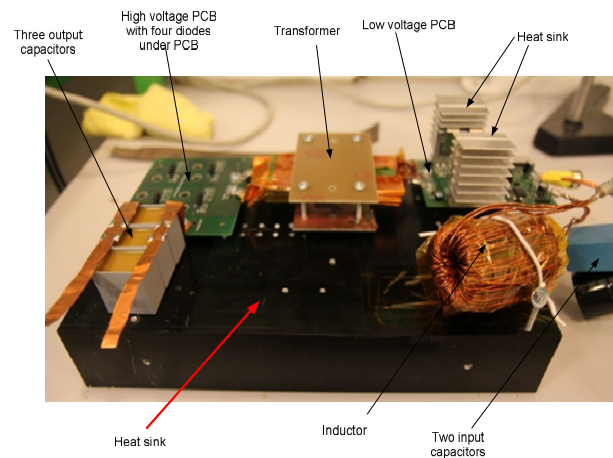

Fig. 1. Investigated Full-bridge boost isolated converter.

In order to find the hottest spot in the components of converter for temperature measurements, the TROTEC IC080LV infrared camera was used. The radiation emissivity of the black anodized heat sink is in the range from 0.82 to 0.86 and the emissivity was set equal to 0.85 on IR camera [2]. The images obtained by thermo-camera are shown in Fig. 2. The scale of temperature is different and fluctuating due to emissivity and other factors.

However the main aspect is not to measure the temperature as a physical quantity, but to find hot spots that affect the thermal load of entire system. The heat sinks seem colder in the images only due to emissivity, because they have the lowest emissivity comparing with transformer, inductor or PCB.

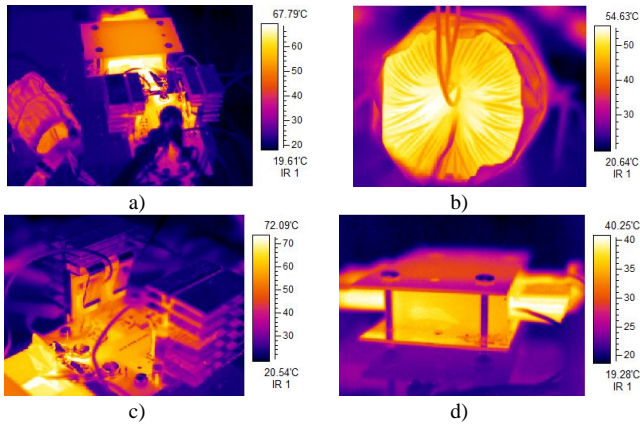

Fig. 2. The thermal view of whole converter (a); inductor temperature distribution (b); transistor and heat sink temperature distribution (c); transformer temperature distribution (d).

As it can be seen the hottest spot is in the inside of the inductor. Transformer has also hottest spots inside the core and around its windings. The transistor and the points which are very close to it reach highest temperature values. Other components of the converter are neglected, because they have a very low temperature and therefore are not investigated.

The thermocouples are chosen for use in temperature measurements; the thermocouple type is K-type (Chromel +, Alumel -). They are used with a multimeter Meterman 38XR in order to get the temperature readings. The attached thermocouples for whole converter are shown in Fig. 3. The temperatures were measured on transistor tab/case, on both heat sinks between transistors, inside of the inductor, inside the transformer, under the top winding layer and bottom layer.

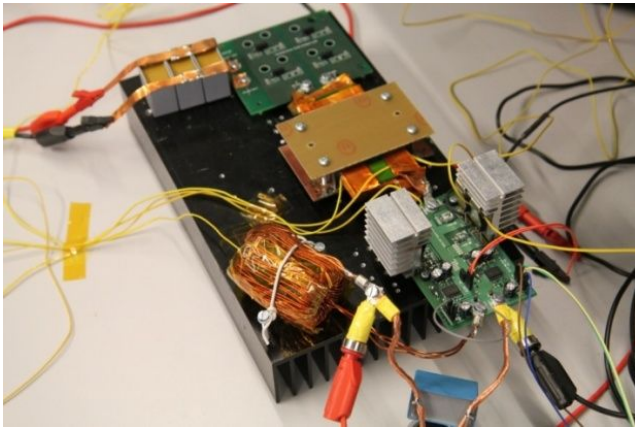

Fig. 3. Full-bridge isolated boost converter with attached thermocouples (yellow wires).

The thermocouple on the transistor tab/case was attached by soldering. On the heat sink, a small hole was drilled and a thermocouple was glued inside the hole. The thermocouple used on inductor was attached between inside windings with slightly covered thermal grease. In case of the transformer, the attachment principle was the same as for the inductor.

Afterwards, the measurements were performed when converter reached the steady-state conditions (constant temperature reading), but the values in this case contained an interference component due to electrical/magnetic noises which significantly influence correct temperature readings. Therefore the temperature measurements were made when

converter is turned off and the readings immediately were registered in order to avoid errors caused by converter-generated interference. For this reason a simple test was made to check how fast the temperature decreases by 1 °C degree on each measured component. While 1 °C degree was lower than initial temperature, the time was approximately in the range 5 seconds-7 seconds for all thermocouples. Then, the measurements were accomplished and repeated 10 times for taking average measurement readings from multimeters. So, the maximum error according to taken readings could be 1 °C degree. It can be assumed that the errors can be neglected, because they don't influence the measurement significantly.

The measurements were also repeated 10 times under each different output power in order to account for the random experimental errors and to obtain the average temperature value. The measurements were made under variable output load, input voltage and at 790 V output voltage with 750 ohm resistive load and 50 V input voltage. Table I presents several of temperature measurement cases and other important readings.

TABLE I. MEASURED TEMPERATURES UNDER EACH CASE OF INPUT AND OUTPUT POWER.

Resistive load, []	Output voltage, [V]	Input voltage, [V]	Temperature inside the transformer, [°C]	Temperature at the top of transformer windings, [°C]	Temperature of the bottom side of transformer core, [°C]	Inductor temperature, [°C]	Heat sink temperature, [°C]	Tab (case) of transistor temperature, [°C]	Heat sink temperature, [°C]
380	620.3	50	70	61	54	58	70	77	69
750	789.1	50	79	67	63	60	72	78	71
750	790.1	60	72	63	58	46	53	55	52
750	789.5	40	77	67	60	65	71	77	70
950	790.9	50	73	62	57	45	55	61	54

Almost in all cases the temperature variation was relatively small; when a smaller output resistance value (380) was used, in order to get output 790 V, the temperature can be much higher (see Table I).

After temperature measurements, one particular case was chosen which was used for power loss estimation and modelling in COMSOL Multiphysics. The measurement parameters in this case were: resistive load 750 ohm, output voltage – 789.1 V, input voltage – 50 V. These operating parameters are common for this type of converter.

III. THERMAL MODELLING OF SEPARATE COMPONENTS OF POWER CONVERTER IN COMSOL MULTIPHYSICS

In order to proceed with the thermal modelling of power converter, the individual components of power converter should be created in order to ensure the modular structure of the entire model. The following most critical components are used: the transformer, inductor and two shiny aluminium heat sinks with attached transistors. Each heat sink has two attached transistors. Each component of the converter is modelled by a simplified geometry, in order to obtain a

number of degrees of freedom of the entire model as low as possible.

Primarily, in order to find a simplified model of each power converter component, the temperature difference was compared between accurate and simplified models.

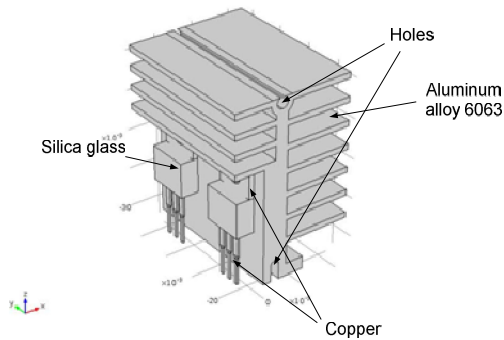

Fig. 4. Model of two transistors attached to the heat sink with designated materials (accurate model).

Firstly, the two transistors attached to the heat sink were investigated in order to compare accurate and simplified heat sink models and determine how much the simplified model impacts the thermal modelling of this component. The heat sink type OS515 from AAVID THERMALLOY Company [3] was used. The accurate model of heat sink with two transistors created in Comsol Multiphysics is presented in Fig. 4.

The simplified heat sink model was designed without thermal interface material (TMI), because it introduces an error of approximately 1 °C at 5,031 W power losses (value obtained from modelling results); therefore we chose to neglect the absence of TMI. The thermal conductivities of all materials designated using Comsol Multiphysics are listed in Table II [4], [5].

TABLE II. THERMAL CONDUCTIVITY AND EMISSIVITY OF EACH MATERIAL.

Material	Thermal conductivity [W/m ² *K]	Emissivity
Heat sink and transistors		
Silica glass	1.38	0.92
Aluminum alloy 6063 (shiny)	200	0.1
Copper	400	0.2
Silicon	150	-
FR4	0.3	0.6
Inductor		
Core material (Carbonyl E Iron powder)	50.16	-
Copper	400	0.2
Kapton tape	0.12	0.08
Transformer		
Core material 3F3 (MnZn)	3.5	0.78
Copper	400	0.2
FR4	0.3	0.2
Steel AISI 4340	54	0.04

The heat transfer in solid physics and steady state condition is used for modelling, both for transformer and inductor modelling. In description of physics and boundary condition in COMSOL simulation, the convective coefficient and emissivity were applied; however the emissivity can be neglected due to insignificant impact on

the total heat transfer ($\epsilon = 0.1$). The average ambient temperature for all simulations cases, including transformer and inductor, was selected equal to 20 °C; this value was chosen from the ambient temperature measurements. The convective coefficient is applied equal to 7.23 W/m²*K. For comparison of simplified and detailed model, the temperature was measured on the transistor chip.

Also, the chip size of transistor was investigated. The purpose of this investigation was to analyse how the chip temperature varies dependent on chip size with the same boundary conditions as in previous modelling. After investigation, it was noticed that the size of transistor chip can influence the maximum value by approximately 0.45 °C degree between small (3 × 3 mm) and larger (5 × 7 mm) chip. Small chip had higher temperature than the large one.

The power loss impact of transistor pins for temperature increase was evaluated, because the pins are subjected to a flow of strong electrical current. The electrical current was measured using oscilloscope and the power per each pin was estimated [6] to be equal to 0.067 W and during modelling it was applied only to drain and source pins. After modelling the chip temperature was higher 2.3 °C than when heat power wasn't applied for transistor pins. Also, comparing accurate and simplified heat sink models, the transistor chip temperature was lower by approximately 2 °C for accurate model.

After the heat sink modelling, the same was accomplished for the inductor component. The spatial model of the inductor is shown in Fig. 5 [7].

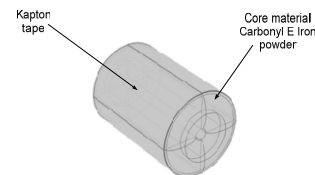

Fig. 5. Spatial geometry of inductor with designated materials.

The inductor was modelled when Kapton tape covers the component, as in real-world case. The used materials and their properties are listed in Table II. The winding block of the same geometry as in real case with the same volume, wrapped around the magnetic core, has been evaluated. The wrapped block is treated as a uniform power source [8]. Thermal conductivities and emissivities are given in Table II.

TABLE III. ESTIMATED POWER LOSSES OF EACH COMPONENT.

Transistor		Inductor		Transformer	
Parameter	Value	Parameter	Value	Parameter	Value
P _{cond}	1.334 W	P _{core}	0.478 W	P _{core}	4.611 W
P _{sw}	3.697 W	P _{DC}	6.464 W	P _{pri}	1.114 W
P _{tot}	5.031 W	P _{AC}	0.635 W	P _{sec}	0.878 W

The convective coefficient is applied equal to 8.1 W/m²*K, however, heat convection of magnetic devices can vary in the range 6-10 W/m²*K [9]. The estimated power losses are applied for core and windings (Table III).

The transformer was modelled and the final model is shown in Fig. 6. The transformer type E64/10/50 was used

[10].

The transformer winding block length is 98.5 mm, width – 53.80 mm, height – 10.2 mm. PCB (FR4) thickness is 1.6 mm, length – 100 mm, width – 60.7 mm. The PCB is used on both core sides. The properties of selected materials are presented in the Table II [11].

The convective coefficient is applied equal to $6.52 \text{ W/m}^2\cdot\text{K}$. The estimated power losses are applied for core and winding block from Table III [12].

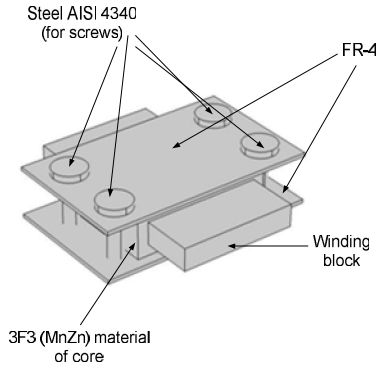

Fig. 6. Spatial model of transformer with designated materials.

The dimensions of windings and insulators are relatively small, what leads to a denser finite element mesh and, subsequently, modelling can take very long time. Therefore it is necessary to make some model simplifications. One method can be used when thermal conductivity of the winding block is estimated as equivalent [13], [14]. Each conductor is defined as a heat source inserted within the block. The internal heat transfer mechanism of the planar transformer is dominated by conduction; thus the equivalent thermal conductivity of a uniform block can be calculated by integrating the conductors and insulators. Firstly, thicknesses of conductor and insulator should be known. The equivalent thermal conductivity (k_{eq}) is estimated by equation

$$k_{eq} = \frac{h_{Cp} + h_{Dp} + h_{Cs} + h_{Ds}}{\frac{h_{Cp}}{k_C} + \frac{h_{Dp}}{k_{Dp}} + \frac{h_{Cs}}{k_C} + \frac{h_{Ds}}{k_{Ds}}}, \quad (1)$$

where h_{Cp} – thickness of conductor (primary side – 0.2 mm), h_{Cs} – thickness of secondary side conductor (70 μm), h_{Dp} – thickness of insulator (FR-4 – 0.2 mm), h_{Ds} – Kapton tape thickness (0.1 mm), k_C – thermal conductivity of conductor ($400 \text{ W/m}\cdot\text{K}$), k_{Dp} – thermal conductivity of Kapton tape ($0.12 \text{ W/m}\cdot\text{K}$), k_{Dp} – FR4 thermal conductivity ($0.3 \text{ W/m}\cdot\text{K}$). The equivalent thermal conductivity was obtained equal to $0.38 \text{ W/m}\cdot\text{K}$.

In modelling, a large chip and 0.067 W heat power per each transistor pins was used in order to make modelling results as close as possible to measurement results. Despite the potential error of temperature values, the simplified heat sink was chosen for use in modelling due to advantages given by geometry simplification. Mentioned temperature errors could be evaluated by separate approximations, because sophisticated geometry influences the modelling duration and can introduce additional mesh generation issues. Also, the modelled transformer had quite a high temperature, because there was no heat sinking through

screws. Next subchapter discusses the thermal design of the entire power converter and how previously designed models of separate components are introduced into the overall converter thermal design.

IV. THERMAL MODELLING OF POWER CONVERTER

The whole power converter placed on the heat sink which acts as cooling pad/board was modelled. All constituting components were placed on the heat sink in order to decrease their temperature which was higher compared to previous modelling of separate components. Then, the whole converter was modelled and results were compared with actual experimental temperature readings which also will be summarized below.

During the modelling procedure, all previous modelled components are imported into Comsol Multiphysics. The transistors with heat sinks are placed on the PCB, and PCB is attached to the main heat sink using four screws (see Fig. 7). Transformer was also attached to the heat sink using four screws. For inductor attachment the Kapton tape was used under it on the heat sink. The Kapton tape was used in modelling to reflect the real practical case, when additional shielding is required, despite the fact that the inductor temperature without tape can be decreased dramatically by the heat sink. Therefore, the Kapton tape with dimensions $0.06 \text{ m} \times 0.08 \text{ m}$ was also used to cover the inductor in this case.

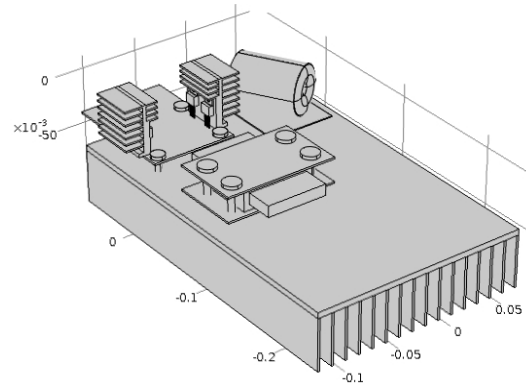

Fig. 7. Spatial geometry of power converter.

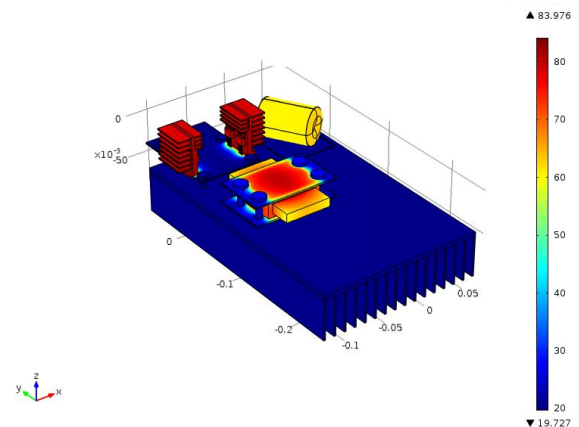

Fig. 8. Temperature distribution in entire power converter (temperature is in $^{\circ}\text{C}$ scale).

When describing the boundary conditions, the ambient temperature was applied equal to $20 \text{ }^{\circ}\text{C}$ degrees. All components were defined with the same convection boundary condition values as previously, because all pins

attached to the main heat sink had very small surface for convection. However, heat sink and PCB are used with $6.24 \text{ W/m}^2\cdot\text{K}$ and $5.31 \text{ W/m}^2\cdot\text{K}$, respectively. Also, the inductor and two heat sinks touch the main heat sink via very small area, because one of them has circular form and other has small flat area which covers PCB. The black anodized aluminium ($\epsilon = 0.85$) was used for the main heat sink. Furthermore, the emissivity for all three components is very low compared with the main heat sink emissivity, therefore the emissivity of the main heat sink plays a decisive role in heat transfer.

The modelling results can be seen in Fig. 8. Actual measured temperatures were compared with simulated temperatures at the same points of the converter. The comparison is shown in Fig. 9. The inside temperature of transformer, top winding of transformer, bottom side layer of transformer, inside inductor, heat sink 1, case of transistor, heat sink 2 are denoted as ITT, TWT, BSLT, II, HS1, CT, HS2, respectively.

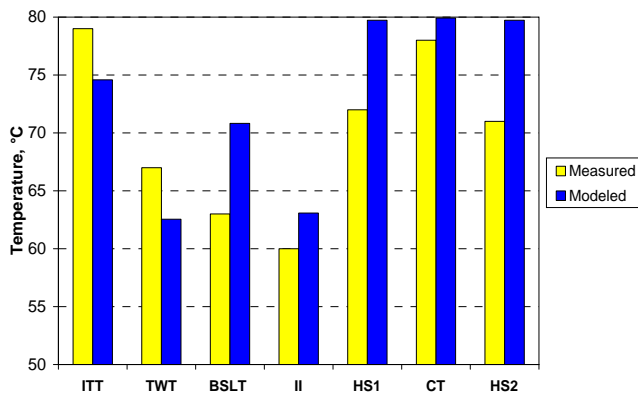

Fig. 9. Comparison of simulated and measured temperatures (with mesh of 1535771 elements).

The simulated temperatures were very close to actual measured results. The maximum error of temperature simulation was $8.17 \text{ }^\circ\text{C}$ (with mesh of 1535771 elements) and is quite a reasonable value, because such difference in temperatures can still be used for prediction of the overall converter temperature trends. Usually, power converter is

designed to keep temperature below $100 \text{ }^\circ\text{C}$, so the $8.17 \text{ }^\circ\text{C}$ degrees error in this case is a significant value for temperature estimation, therefore this issue should be solved in further works by improving mesh refinement or modelling methodology.

V. IMPROVING THERMAL DESIGN AND INTEGRATION OF POWER CONVERTER

This chapter discusses how to improve thermal design and cooling of boost isolated power converter and to suggest the layout of components with higher integration compared to the model shown in Fig. 1. The simulated temperatures were compared with results for previous power converter.

This type of power converter has input filter consisting of two capacitors and its heat is neglected, because in experiments the filter was cold (see Fig. 1 and Fig. 10). The dimensions of two capacitors are: diameter 35 mm, height 30.5 mm, another one – $41 \text{ mm} \times 20 \text{ mm} \times 37 \text{ mm}$. Also, output filter consist of three same type capacitors which are modeled together as a block (see Fig. 10). The dimensions of capacitor block are $30.5 \text{ mm} \times 20.5 \text{ mm} \times 30.5 \text{ mm}$. The heat power also is neglected for this component as for input filter due to low temperatures. The high voltage PCB (see Fig. 1) was used with four diodes placed under the low-voltage PCB in order to reach higher integration. Each of the diodes contributes the heat power around 1 W [1]. The high-voltage PCB dimensions are $0.105 \text{ m} \times 0.088 \text{ m} \times 0.0016 \text{ m}$.

The heat sink was used of the same type as in previous case, with different length of 0.2 m . The heat sink is covered with mica ($0.17 \text{ m} \times 0.18 \text{ m} \times 0.001 \text{ m}$) in order to ensure electrical insulation; for example, inductor, transformer and four diodes which are attached to the heat sink. The mica is used in a form of a large sheet in order to simplify the design in Comsol Multiphysics. Also, the output and input filters are placed on mica, although in practice it is not used in all cases. The output and input filters were placed in touch with inductor (the wires were covered by lacquer) in order to increase the thermal conductivity through them to the main heat sink. Furthermore, filters can improve cooling by heat convection [9].

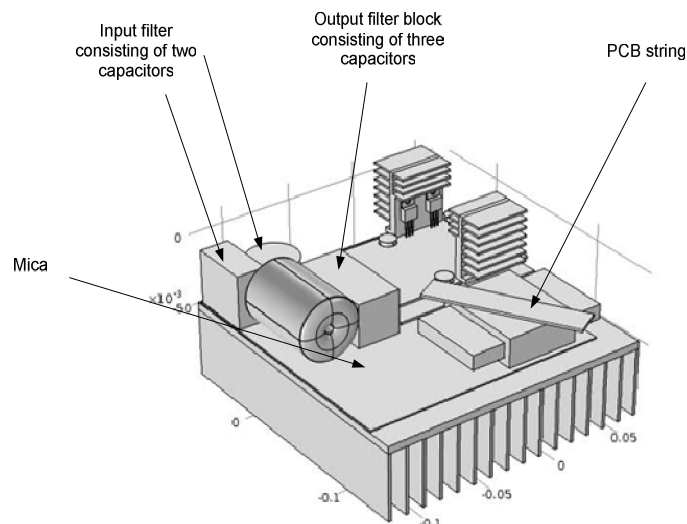

Fig. 10. Spatial geometrical model of proposed converter integration mode.

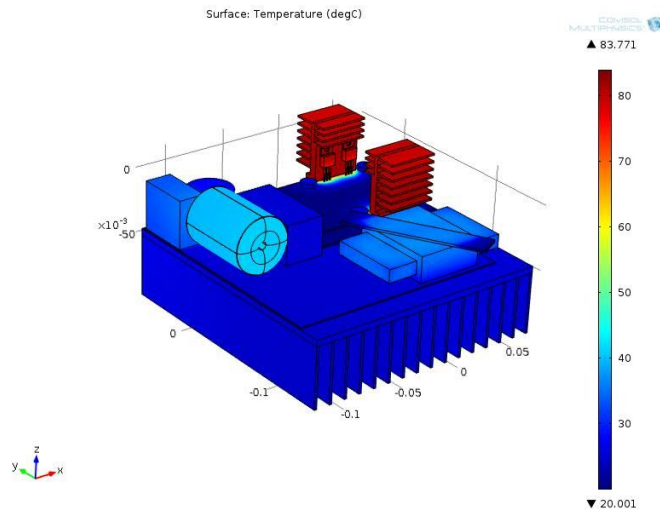

Fig. 11. The thermal distribution in power converter (temperature is in °C scale).

The transformer was laid on the mica, in order to increase the thermal conduction to the heat sink. The vertical position was considered, but discarded as not reliable in this case due to contacts and stress for connecting wires, especially, in case of on-board applications. Thus, the bottom PCB plate of transformer was removed and the transformer can be fixed with PCB strip on the top by using two screws. The strip was chosen to be placed diagonally in order to get a stronger fixation. Moreover, a tightly attached strip could increase convection-based cooling. The two mentioned screws are neglected in modelling due to their relatively poor cooling impact on the heat sink (see Fig. 8, also verified by practical measurements). Also, these screws make the geometry more complex for modelling purposes and thus not so effective.

The structure which consisted of transistors attached to the heat sink, low-voltage PCB and four screws as fixing elements remained the same as in previous modelling (see Fig. 1 and Fig. 7).

The same boundary conditions are used as previously [15], however only for introduced capacitors the convection was applied equal to $5 \text{ W/m}^2\cdot\text{K}$. The temperature modelling results are shown in Fig. 11.

The modelling results are shown in Fig. 12, where they are compared to the first modelling. Since, the low-voltage PCB had the same properties and the same heat sink, the temperatures of these components remained the same.

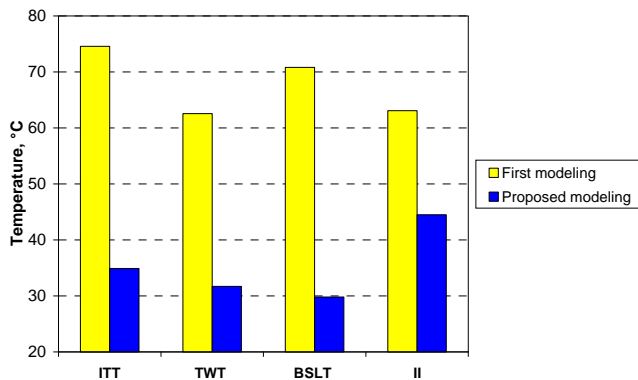

Fig. 12. Comparison of temperatures of previous modelling and proposed layout (with mesh of 1535771 elements).

Next modelling was accomplished with AlN and Al₂O₃

Direct Bonded Aluminum (DBA) substrate which has thermal conductivity equal to $170 \text{ W/m}\cdot\text{K}$ and $28 \text{ W/m}\cdot\text{K}$, respectively. This is used in order to decrease temperatures of transistors together with heat sinks. The transistor temperatures are compared in Fig. 13.

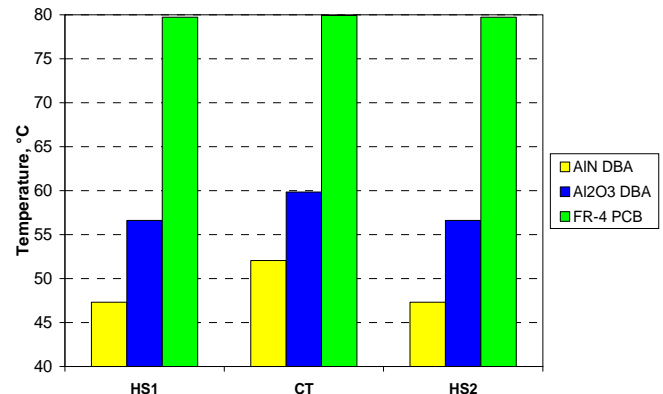

Fig. 13. PCB versus DBA technology with AlN and Al₂O₃.

To summarize, the new layout decreased the temperature of magnetic devices and integration was increased in power converter. As discussed previously, the filter helps to decrease the temperature of inductor; however, one capacitor influences that mostly, because it has the largest contact area and directly touches wires. Output capacitor and input circular capacitor has a very small contact area and even if the thermal conductivity can be quite high, the cooling is poor. In case of transformer, the cooling was improved very strongly. Comparing the PCB, AlN, Al₂O₃, it can be seen that AlN material gives the best thermal cooling improvement and thermal distribution over substrate. Also, comparing the thermal conductivities of different DBA materials, the Al₂O₃ material doesn't have a very large difference comparing with AlN, however thermal conductivities differ around 6 times.

VI. CONCLUSIONS

The library of thermal models of power converter components was created, which can be used for any type converter with the same components.

Comparing the measured and simulated temperatures of power converter components, it was found that the

temperatures differ within 8.17 °C, compared to experimental temperature readings. The thermal modelling could be made more accurate and the mesh refinement or improved modelling methodology could be used in order to reduce the temperature error. It is also quite difficult to estimate the convection coefficient, but the thermal modelling can help to vary this coefficient if geometry or boundary conditions are defined quite accurately.

A new layout was proposed for the entire power converter design which provides an improved cooling for most critical components. The inductor temperature was decreased the least – it was 1.41 times less compared to previous model; the inside temperature of transformer was 2.13 times less, top winding of transformer – 1.97 less, the side of bottom winding was 2.37 less. In case of AlN DBA substrate, the temperature of transistor and heat sink was lowered with ratio 1.53 and 1.68, respectively. In case of Al₂O₃ DBA substrate, the temperature of transistor heat sink was lowered with ratio 1.33 and 1.4, respectively. Also, the area of boost isolated power converter placed on heat sink was reduced 1.5 times compared to the previous version, however the height remained the same.

ACKNOWLEDGMENT

The authors thank CELCORR/CreCon consortium (www.celcorr.com) for thermal imaging camera used in this work.

REFERENCES

- [1] P. Tarvydas, A. Noreika, Z. Staliulionis, “Analysis of Heat Sink Modeling Performance”, *Elektronika Ir Elektrotechnika*, vol. 19, no. 3, pp. 49–52, 2013. [Online]. Available: <http://dx.doi.org/10.5755/j01.eee.19.3.3695>
- [2] *Emissivity values*. [Online]. Available: http://www.design1st.com/Design-Resource-Library/engineering_data/ThermalEmissivityValues.pdf.
- [3] *Heat sink dimensions*. [Online]. Available: http://www.aavidthermalloy.com/cgi-bin/process.php?pf=euro_exdisp.pl&Pnum=0s515&LengthUnits=mm&ExLength=150.00&TReff=0.000.
- [4] *Materials property data*. [Online]. Available: <http://www.matweb.com/>.
- [5] *Emissivity of material*. [Online]. Available: <http://www.everestinterscience.com/info/emissivitytable.htm>.
- [6] R. W. Erickson, D. Maksimovic, *Fundamentals of Power Electronics* p. 883.
- [7] *Specifications of toroids*. [Online]. Available: <http://toroids.info/T157-2.php>.
- [8] N. Delmonte, M. Bernardoni, P. Cova, R. Menozzi, “Thermal Design of Power Electronic Devices and Modules”, in *Proc. COMSOL Conf Milan*, 2009.
- [9] A. Van den Bossche, V. Valchev, “Thermal Design of Transformers and Inductors in Power Electronics”, *Quatrième Conférence Internationale sur le Génie Electrique (CIGE 2010)*, Algeria, 2010. (in French)
- [10] *Magnetic core dimensions*, Ferroxcube. E64/10/50 datasheet. 2008-09-01.
- [11] *Magnetic material properties*, Ferroxcube. Soft ferrites, Ferrite materials survey. 2008-09-01
- [12] Z. Zhang, R. Pittini, M. A. E. Andersen, O. C. Thomsen, “Analysis of Planar E+I and ER+I Transformers for Low-Voltage High-Current DC/DC Converters with Focus on Winding Losses and Leakage Inductance”, in *Proc. Int. Power Electronics and Motion Control Conf. (IPEMC)*, 2012, pp. 488–493.
- [13] P. Cova, N. Delmonte, “Thermal modelling and design of power converters with tight thermal constraints”, *Microelectronics Reliability*, vol. 52, no. 9–10, pp. 2391–2396, 2012. [Online]. Available: <http://dx.doi.org/10.1016/j.microrel.2012.06.102>
- [14] W. Zhang, “Integrated EMI/Thermal Design for Switching Power Supplies”, Virginia Polytechnic Institute and State University, 1998.
- [15] *COMSOL User's Guide* (version 4.3), chapter 13, “The Heat Transfer Branch”, COMSOL. p. 1292, 2012.