

Optimization of a Standard Bidirectional DWDM Solution

I. Trifonovs, V. Bobrovs, G. Ivanovs

Department of Telecommunications, Riga Technical University,

Azenes str. 12, LV-1010 Riga, Latvia, phone: +371 29489686, e-mail: ilja.trifonovs@rtu.lv

crossref <http://dx.doi.org/10.5755/j01.eee.115.9.745>

Introduction

There is an increasing demand for Dense Wavelength Division Multiplexing (DWDM) systems to support a set of network requirements (span length, total distance, capacity, etc) typically associated with previously distinct network application categories such as access, metro, regional, and long haul [1–6].

Vast majority of telecommunications service providers (TSP) use DWDM systems as a backbone nowadays. Due to the constant growth of information exchange worldwide, DWDM systems built are in need of frequent cost-effective optimization. There are a lot of ways how to evaluate and optimize a real working DWDM system. One of the most efficient ways to perform these tasks is to use simulation software.

Simulation software takes all kinds of parameters into account for DWDM system, through which the measurement results of various instruments can be get, and it can simplify design process and save a lot of time and funding for theoretical research [1].

In order to do so a thorough inspection of hardware documentation is needed as well as various measurements of the components of transmission system must be taken.

This work demonstrates the approach of approximation towards a real-working DWDM system from one of national TSP's by simulating it, improving the simulation and giving proposals for further optimization of the transmission system.

Experimental and simulation technique

Our experimental part is based on taking a standard real-working bidirectional DWDM solution (transmission of four 10 Gbit/s channels over the optical fiber) of specific TSP for further research and simulation. Technical parameters of chosen transmission system like centre frequency of each channel, input attenuation of optical filters, compensation of dispersion and amplifier gain were taken from hardware specification. Taking into consideration the fact, that the given transmission system was already launched and couldn't be stopped due to customer traffic, the measurement possibilities were

limited. Length and loss of optical fiber were measured with reflectometer beforehand and can be seen on Fig. 1.

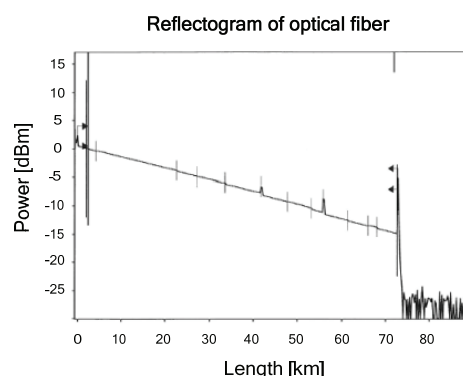

Fig. 1. Reflectogram of optical transmission link

We were also able to take signal spectrum of one of the terminated channels as well as the spectrum of multiplexed signal at the monitor port of amplifier. These measurements were made using optical spectrum analyzer (OSA).

Our simulation first part is based on building identical DWDM transmission system in all-optical network simulator OptSim 5.0 from RSoft Design Group and to compare the spectrograms received with the ones gained from measurements.

More qualitative approach towards the evaluation of simulation is based on analyzing such system parameters as the bit error rate (BER) and optical signal to noise ration (OSNR) using the opportunities, provided by simulation software. In the present work, we show spectrum and eye diagrams for various simulation setups, since they are a fast way how to approximately evaluate a system performance; respectively, an eye has to be opened wide enough and spectrum diagrams should be regulars without negative multipeak structure for good system performance [2]. An eye diagram shows the patterns of the electrical signal after detection. In other words, the waveform trajectory from the start of period 2 to the start of period 3 is overlaid on the trajectory from the start of period 1 to the start of period 2, and so on, for all bit periods [4]. The eye

height shows the amount of noise, that can be tolerated by the signal and the eye width shows the time over which the waveform can be successfully sampled.

Our simulation second part is based on improving previously simulated DWDM transmission system. There are a lot ways to perform this task. Most classic are increasing the length of optical fiber, decreasing the spacing between channels, increasing the number of channels and increasing transmission speed of channels. Keeping in mind that we are talking about an existing DWDM system, the most expected scenario is the demand of more 10 Gbit/s channels on the same optical link. So we have chosen to decrease channel spacing and to increase number of channels.

Experimental and simulation model

DWDM technology is known as a kind of technology coupling and transmitting optical signals of different frequency (wavelength) to an optical fiber by using the tremendous bandwidth of single mode fibers (SMF) low-loss area in DWDM system, which is not only conducive to the realization of switching and recovery in optical networks but also convenient to the expansion and upgrade, and thus the further realization of transparent and high survivability optical networks [1].

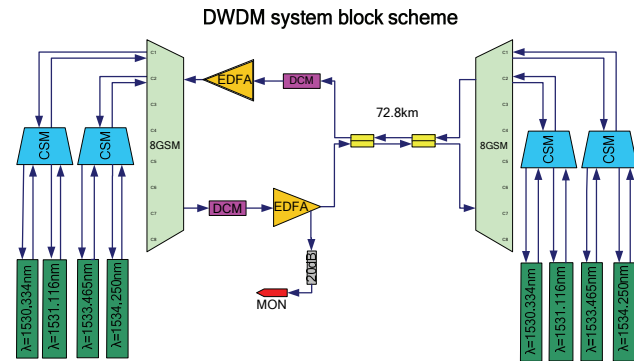

Fig. 2. Block scheme of a bidirectional DWDM solution

Fig. 2 shows the block scheme of a standard DWDM system with a link length of 72.8 km (standard link length for 10 Gbit/s solutions with dispersion compensation modules of specific TSP). Two groups of channels are being transmitted into the line. Each consists of two channels with spacing 100 GHz. The centre wavelengths are: $\lambda_1=1530.334$ nm, $\lambda_2=1531.116$ nm and $\lambda_3=1533.465$ nm, $\lambda_4=1534.250$ nm. The channels are being combined into channel splitter modules (CSM) and afterwards groups of channels are being combined into group splitter module (8GSM). Then the multiplexed signal goes to dispersion compensation module (DCM). Inside which is a 15 km long optical fiber with parameters loss=0.55 dB/km, D=-80 ps/nm.km. Afterwards the signal goes to a fixed gain (20dB) erbium doped fiber amplifier (EDFA) which has a monitor port giving out 1% of amplifier's output power. Afterwards the signal goes to 72.8 km long SMF with loss 0.219 dB/km and is being demultiplexed the same way at the other end of transmission system. The reverse transmission is identical to the described.

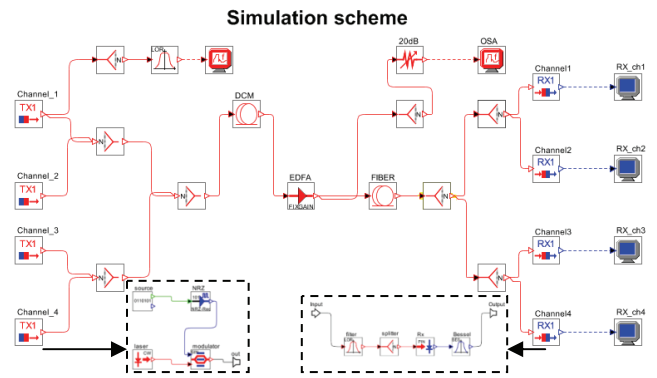

Fig. 3. Simulation model of a bidirectional DWDM solution

Fig. 3 shows the simulation model of the given DWDM system. The transmitter block consists of four externally modulated outputs, each of them consisting of a data source, a driver, a laser and external Mach-Zehnder (MZ) modulator. The laser is always switched on and its light waves are modulated via the electro-optic MZ modulator by data pulse sequence output of a pulse pattern generator (PPG), using the principles of interferometric constructive and destructive interference to present ON and OFF of the light waves [2]. After the transmission block the signal is sent through optical combiners to dispersion compensation fiber (DCF) and fixed gain optical amplifier, after that directly to a standard-single mode fibre (SSMF). At the end of SMF the channels are demultiplexed; each channel is optically filtered, converted to electrical one and then electrically filtered.

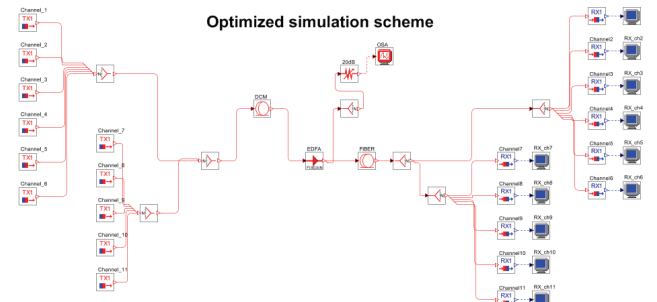

Fig. 4. Simulation model of optimized bidirectional DWDM solution

Fig. 4 shows the optimized simulation model of the given DWDM system. We have decided to reduce channel spacing two times (from 100 GHz to 50 GHz) and to increase number of channels to fill all the available bandwidth. So we have terminated 11 channels with 50 GHz (0.782 nm) spacing in bandwidth 1530.334 – 1534.250 nm.

To evaluate the system performance several measurements have been taken. We were interested in observing the optical spectrum at monitor port of optical amplifier, as well as eye diagrams and BER.

Results and discussions

The aim of this section is to compare the results, received from simulation of DWDM system with the ones received from measurements, then to numerically evaluate

the performance of simulated DWDM system, before and after optimization.

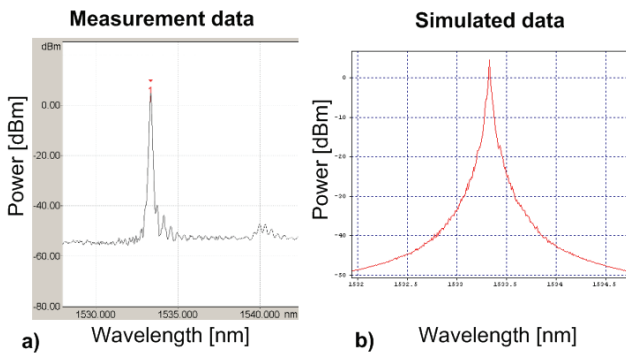

Fig. 5. Signal spectrum of modulated signal of channel $\lambda_3 = 1533.465$ nm: a – measured with OSA; b – simulated in OptSim

Fig. 5 depicts optical signal spectrum of 10 Gbit/s channel with centre wavelength $\lambda_3 = 1533.465$ nm taken before the signal goes into optical combiner. The peak power of the signal, received from measurement (Fig. 5, a) was $P_p=4.67$ dBm; the peak power calculated by simulation software (Fig. 5, b) was $P_p=4.62$ dBm.

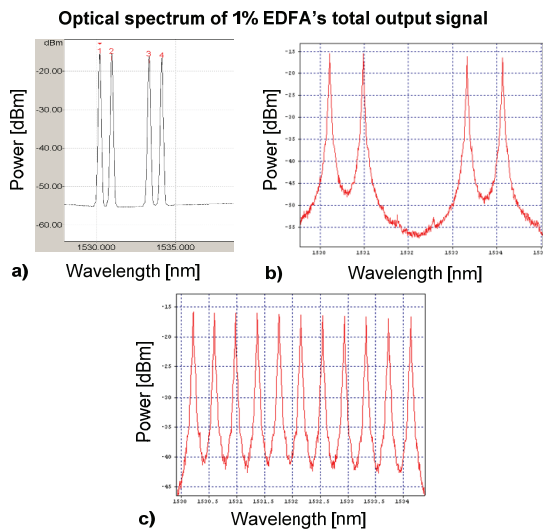

Fig. 6. Signal spectrum of 1% EDFA's total output signal: a – measured with OSA; b – simulated in OptSim (original solution); c – simulated in OptSim (optimized solution)

Fig. 6 depicts measured output optical signal spectrum of EDFA's monitor port, which is 1% of EDFA's total output power (Fig. 6, a); output optical signal spectrum of fixed gain optical amplifier of simulated DWDM system reduced by 20 dB (Fig. 6, b); output optical signal spectrum of fixed gain optical amplifier of optimized DWDM system reduced by 20 dB (Fig. 6, c).

After analyzing the results received from simulation and comparing them with the measured ones, we can state, that they are very similar. Simulated optical spectrums of input signals and of EDFA attenuated total output signal differ from measured ones for 3% at the most. This leads us to the thought that the results of simulation are pretty trustworthy and we can continue to use this approach for our further research.

Eye diagrams of the received signals

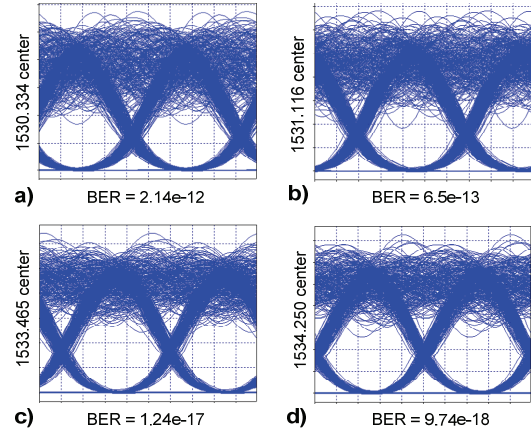

Fig. 7. Eye diagrams of each channel's output electrical signal: a – $\lambda_1 = 1530.334$ nm; b – $\lambda_2 = 1531.116$ nm; c – $\lambda_3 = 1533.465$ nm; d – $\lambda_4 = 1534.250$ nm

To evaluate the performance of simulated DWDM system eye diagrams of each channel output have been taken. Fig. 7 shows eye diagrams and BER of all four channels. As we can see, the eye opening is very good and BER is also low enough, what ensures quite descent performance of DWDM system. And it was more or less expected, as the system simulated, perfectly works in the field. The noise above the eye shows, that there is either signal excursion or wasted power, what shows that the system is not perfectly configured, but quite operational. As we can see, the BER value is still sufficient and further optimization is possible.

Eye diagrams of the received signals

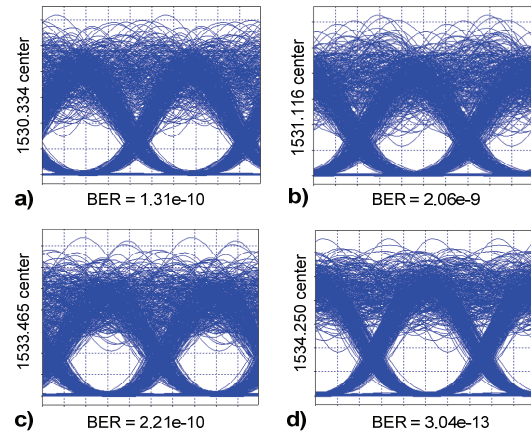

Fig. 8. Eye diagrams of each channel's output electrical signal of optimized DWDM system: a – $\lambda_1=1530.334$ nm; b – $\lambda_2=1531.116$ nm; c – $\lambda_3=1533.465$ nm; d – $\lambda_4=1534.250$ nm

The next step is to evaluate the performance of optimized DWDM system simulation. Where the spacing between channels is decreased twice (50 GHz) and all available bandwidth is filled with 11 channels 10 Gbit/s each. When reducing channel spacing for a given bit rate per channel to increase spectral efficiency in DWDM systems, interchannel interference (ICI) and nonlinear effects become more and more significant [3].

Fig. 8 shows eye diagrams and BER of the same four channels of optimized DWDM system. As we can see as a result of nonlinear effects and ICI, the eye opening became worse and BER also is lower than in previous simulation, as well as noise above the eye increased. As for the BER, it also increased and approached to the critical value 10^{-9} . But it is still sufficient, because $BER=10^{-9}$ is minimum acceptable BER for telecommunication systems. So we can definitely assume that the system will be operational even after the optimization.

Conclusions

In this report we have investigated the performance of a standard bidirectional DWDM solution with dispersion compensation and EDFA amplification where four 10 Gbit/s channels were combined and transmitted over the 72.8 km long optical fiber. The research was based on simulating the given solution and optimizing it.

The simulation model gave us decent results. Signal spectrums of input channels were almost identical to the ones received from real system, as well as EDFA output spectrums were also very much alike.

Further optimization of the system was based on increasing the number of channels transmitted and decreasing the spacing between channels. So we made an optimized DWDM system in simulation software with 11 channels 10 Gbit/s each with channel spacing 50 GHz.

To evaluate the performance of simulated DWDM system eye diagrams of each channel output have been analyzed. In comparison to the original system, eye opening became worse and BER increased and almost

reached the critical value of 10^{-9} , but this is still acceptable for a normal operation of transmission system.

Our final conclusion would be that specific real-working DWDM solution can be successfully optimized according to our proposed strategy and the system capacity may be increased for up to 110 Gbit/s. However if there is a plan to increase the efficiency of the system even more it should be reconfigured, but in order to do it successfully the system should be examined more thoroughly and this cannot be done without affecting the traffic.

References

1. **Yan G., Ruixia Z., Weifeng D., Xiaorong C.** Point-to-Point DWDM System Design and Simulation // Proceedings of the 2009 International Symposium on Information Processing, 2009. – pp. 090–092.
2. **Bobrovs V., Ivanovs G.** Investigation of Different Modulation Formats Simultaneous Transmission in WDM Systems // Electronics and Electrical Engineering. – Kaunas: Technologija, 2010. – No. 7(103). – P. 109–112.
3. **Francia C.** Constant step-size analysis in numerical simulations for correct four-wave-mixing power evaluation in optical fibre transmission systems // IEEE Photonics Technology Letters, 1999. – Vol. 11. – P. 69–71.
4. **Hancock J.** Jitter – Understanding It, Measuring It, Eliminating It. Part 1: Jitter Fundamentals // High Frequency Electronics, 2004. – Vol. 4. – P. 44–50.
5. **Bobrovs V., Ivanovs G.** Comparison of Different Modulation Formats and their Compatibility with WDM Transmission System // Latvian Journal of Physics and Technical Sciences, 2008. – No. 2. – P. 6–21.
6. **Tibuleac S., Filer M., Grindstaff S., Atlas D.** Design and optimization of multi-haul DWDM networks // Proceedings of the SPIE, 2006. – Vol. 6354. – Iss. 2. – P. 635421.1–635421.10.

Received 2011 02 15

Accepted after revision 2011 04 03

I. Trifonovs, V. Bobrovs, G. Ivanovs. Optimization of a Standard Bidirectional DWDM Solution // Electronics and Electrical Engineering. – Kaunas: Technologija, 2011. – No. 9(115). – P. 37–40.

In this paper a standard bidirectional DWDM solution is taken for further research. Basing on ITU standards and available resources we have taken a real-working bidirectional 72.8 km reach DWDM system with 40 Gbit/s total capacity for further research. The system terminates four 10 Gbit/s channels and transports them through optical fiber to the total distance of 72.8 km. According to investigated DWDM system we have created a simulation scheme in OptSim software with the real parameters of all modules. In order to prove the accuracy of simulation, its results are compared with the real ones. The goal of this paper is to modify the simulation scheme and to gain results for further optimization of bidirectional DWDM solution. III. 8, bibl. 6 (in English; abstracts in English and Lithuanian).

I. Trifonovs, V. Bobrovs, G. Ivanovs. Standartinės dvikryptės DWDM sistemos optimizavimas // Elektronika ir elektrotechnika. – Kaunas: Technologija, 2011. – Nr. 9(115). – P. 37–40.

Nagrinėjama standartinė dvikryptė DWDM sistema konkrečiu atveju. Pagal ITU standartus ir esamus šaltinius tolesniems tyrimams buvo pasirinkta veikianti dvikryptė DWDM sistema (pasiekiamumas – 72,8 km, pralaidumas – 40 Gbit/s). Sistema, sudaryta iš keturių 10 Gbit/s kanalų, optiniu kabeliu perduoda duomenis 72,8 km atstumu. DWDM sistemoje, naudojant programų paketą „OptSim“, buvo modeliuojama schema su realiais visų modulių parametrais. Gauti modeliavimo rezultatai palyginti su realiais. Šio tyrimo tikslas – modifikuoti modeliavimo schemą ir gauti rezultatus dvikryptei DWDM sistemai optimizuoti. II. 8, bibl. 6 (anglų kalba; santraukos anglų ir lietuvių k.).