

A ‘Binocular’ Method for Detecting Faults in Electrical Distribution Networks with Distributed Generation

Daniel Alcalá¹, Lorena Guadalupe Gonzalez-Juarez², Vanesa Valino³, Jose Luis Garcia¹

¹*Department of Rural Engineering, Technical University of Madrid, Complutense St. – 28040. Madrid, Spain*

²*Department of Power Engineering, University Carlos III of Madrid, Av. Universidad, 30. – 28911. Madrid, Spain*

³*Department of Energy and Fuels, Technical University of Madrid, Rios Rosas, 21 St. – 28003. Madrid, Spain*
d.alcalag@upm.es

Abstract—The increase in the number of renewable energy generating facilities has transformed the electricity distribution network into a Distributed Generation (DG) system. This has given rise to a new monitoring scenario for protective devices already installed across radial distribution networks, which may execute unexpected and inappropriate protective actions that cause loss of supply to consumers. These devices are affected by the new condition of the electricity distribution network, as network currents vary. A common practice is to use electrical impedance-based fault localizers. This work describes a novel method for fault detection in radial networks with DG, which does not require knowing the electrical impedances of the lines that compose the network. The method only requires input data regarding the short circuit currents provided by the main feeder and the DG units in the area in which a fault has occurred. This information is sufficient to allow the area where the fault lies to be identified. The underlying idea is that the measurement of the current at two points provides a binocular view of the fault, thus allowing its location to be pinpointed. The method was tested using the IEEE 13-node test feeder system, locating different types of faults in different areas of a simulated radial network.

Index Terms—Fault location; distributed generation; distribution lines; protection devices.

I. INTRODUCTION

The spreading of Distributed Generation (DG) in power grids is causing problem as well as the associated benefits [1]. In radial electrical networks that involve Distributed Generation, there are important issues related to protective devices; these are fault location (*e.g.* distinguishing between faults in the main feeder from those that occur in branches of the system), and the activation of installed protective devices at appropriate positions to ensure the fault's isolation. DG is becoming increasingly common due to the connection of small-to-medium sized photovoltaic, wind and other electricity-generating systems to the grid. The installation of such systems is particularly common in radial networks, such as rural electricity distribution systems.

Radial electricity distribution systems generally function with loads distributed over power lines. The sections of the electrical feeders of these power lines are usually not homogeneous.

In general, the methods used to estimate the location of faults can be divided into two groups. The first is based on detecting fault-induced high frequency components. This enables the detection of discharges from the low-level breakdown of insulators; the fault direction is determined by filtering the output voltage from stack tuners and comparing the resulting signal levels on each side of a tuned trap circuit unit [2]. These methods are complex and expensive given their need for specially tuned filters.

The second group is based on measuring the voltage and current at the line's end plus the electrical impedances along the line. This allows the distance to the fault to be estimated. Generally, the localization techniques belonging to this group require detailed knowledge of the network (voltage, currents and impedances), and are of limited use in distribution networks that involve DG. The earliest methods of this group use the fundamental frequency voltages and currents at the terminals of a line and the impedances along it; these methods consist in calculating line impedances as seen from the line terminals and estimating the distances of the fault from these terminals [3]. Other methods have also been proposed for radial distribution lines without considering the dynamic nature of the loads [4] or the non-homogeneity of lines [5].

Improved methods are available for use on non-homogeneous lines and for dealing with the dynamic nature of the loads [6]–[9], but they still require the impedances along the line to be estimated. Furthermore, none contemplate the condition of DG. In [10] a fault location based in Norton equivalent of synchronous generator has been proposed also it requires the impedances to locate the fault. Later work in this area has attempted to include DG, however, the only communication from DGs to the rest of the elements in the distribution system that was taken into account was the connection status of each [11]. The present work highlights the advantages of additionally measuring

the currents provided by each DG element to the fault.

Advances made in the fields of electronics and communications have led to the gradual appearance of protection devices in electrical networks. Over time these new technologies have shown themselves to be reliable under all network operating conditions. Indeed, substations are now becoming automatic and these technologies are being implemented worldwide. They are also having an influence on protection and monitoring systems, in fact becoming part of these systems [12], [13], and as such offer new means of locating and protecting against electrical faults.

The architecture of the methods proposed by some authors [14], [11] uses geographically distributed ‘agents’ (systems associated with protective devices, or local systems for measuring current or breaker status, etc.) in a number of Intelligent Electronic Devices (IEDs). An IED is here defined as a hardware environment with the necessary computational, communication and other input/output capabilities to allow rapid communication between agents. Agents take sensory input and produce output actions such as breaker trip signals, adjusting transformer tap settings and switching signals in capacitor banks [14], [11]. Standard IEC 61850 [15] normalises the communication protocols between IEDs [16], [17], and establishes the data transmission time (see Fig. 1); how long this takes is important.

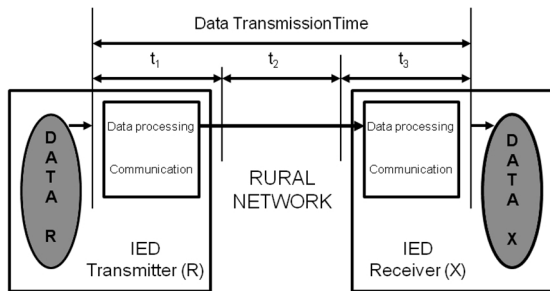

Fig. 1. Data transmission times in Intelligent Electronic Devices. t_1 : time elapsed between the moment the IED produces output data until the message is sent. t_2 : network transmission time. t_3 : the time elapsed between the moment when the IED receives the message from the network until the moment of data extraction.

These methods proposed in the literature for localising faults in networks with DG are not completely satisfactory from an operational point of view, because (a) they all require knowledge of line electrical impedances, and (b) locations are based on distance estimates and may fail with DG. The method proposed in this work overcomes these difficulties since its fault localisation system does not require the electrical impedances along the line be known, and locations are performed correctly through the use of DG line currents.

II. ELECTRICAL FAULTS IN RADIAL DISTRIBUTION SYSTEMS

Different types of electrical faults can occur in radial electrical distribution systems. Table I depicts a summary of common electrical faults that can occur in radial electrical distribution systems, along with the likelihood of their occurrence [18].

When a fault occurs, the value of the short circuit current depends on the fault type (single phase, bi-phase, etc.), and

its localisation in the system, since the Thevenin-equivalent impedance varies with the fault location [18].

TABLE I. TYPES OF FAULTS IN RADIAL NETWORKS.

Fault type	Occurrence (%)	Severity
Three phase (3 \emptyset)	2 %	more severe
Bi-phase to ground (2 \emptyset -G)	5 %	more severe
Two phase (2 \emptyset)	8 %	less severe
Single phase to ground (1 \emptyset -G)	85 %	less severe

Conventional methods for studying faults generally simplify the network to a Thevenin-equivalent circuit in the form of a matrix of impedances defined by (1)

$$\vec{V} = Z \times \vec{I}, \quad (1)$$

where \vec{V} and \vec{I} are $n \times 1$ voltage and current vectors, and Z is an $n \times n$ matrix of complex impedances. In its extended form, (1) is written as in (2)

$$\begin{bmatrix} V_1 \\ V_2 \\ \dots \\ V_n \end{bmatrix} = \begin{bmatrix} Z_{11} & Z_{12} & \dots & Z_{1n} \\ Z_{21} & Z_{22} & \dots & Z_{2n} \\ \dots & \dots & \dots & \dots \\ Z_{n1} & Z_{n2} & \dots & Z_{nn} \end{bmatrix} \begin{bmatrix} I_1 \\ I_2 \\ \dots \\ I_n \end{bmatrix}, \quad (2)$$

The voltages and currents of the above matrix can be represented as shown in Fig. 2.

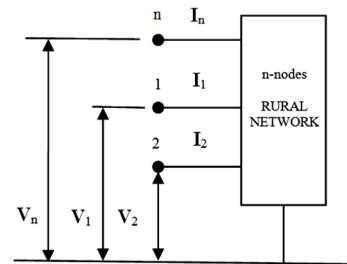

Fig. 2. Voltages and currents in a radial distribution network node.

When seen from a node i , the Thévenin-equivalent impedance can be described as (3)

$$Z_{ii} = \frac{V_i}{I_i}, \quad (3)$$

where $I_k = 0, k = 1, 2, \dots, n, k \neq i$, Z_{ii} is the Thévenin-equivalent impedance seen looking into the distribution network at node i when node i is faulted, V_i and I_i are the voltage and current in node I_i respectively. Impedance Z_{ik} is an impedance relating voltage at a given node i to current injected at another node ($k \neq i$) [19].

Once the Thévenin-equivalent impedance as seen from the node where the fault lies is known, the direct sequence impedance Z_1 , the inverse Z_2 and the homopolar Z_0 can be calculated [19]. Once these variables are known, the short circuit currents of any kind can be determined. Note, therefore, that these conventional methods require the calculation of the network impedances if the short circuit current is to be calculated.

III. FORMULATION OF THE PROPOSED METHOD

The proposed method of fault location searches for the fault node to node, comparing the short circuit currents

provided by the DG and the main feeder to the previously calculated short circuit currents recorded in the off-line situation.

The method is composed by two steps explained in the following subsections A and B, and it was simulated with the IEEE 13-node test feeder system.

A. Off-line Short Circuit Current Computation

The first step in the proposed methodology is the off-line calculation of short circuit currents. For this, the configuration or topology of the network must be known, e.g. the number and location of nodes and line sections, the number and location of the DG units, and the electrical loads across the network.

In the off-line study, two independent studies are performed, as seen in Fig. 3: (a) A load flow analysis is performed to compute the values of the steady-state currents of the Substation (S) and DG units. (b) The short circuit currents injected in the network from each DG unit and the Substation (S) are then studied for the different short circuit types (3 \emptyset , 2 \emptyset -G, 2 \emptyset , 1 \emptyset -G) simulated at each node. These short circuit currents (I_{cc}) are registered in a table for the computations of the next step.

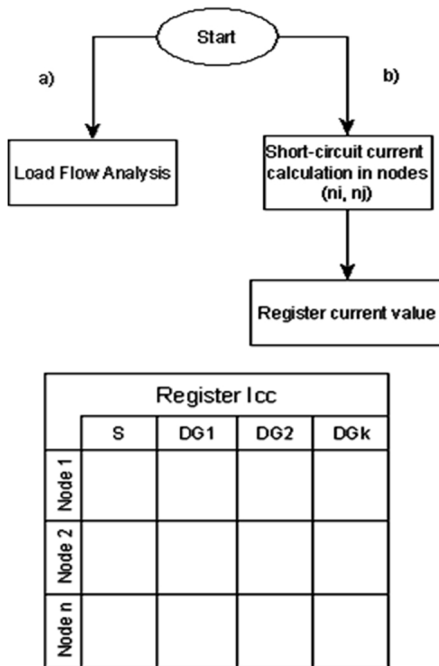

Fig. 3. Proposed method off-line short circuit current computation step.

B. Fault Detection through On-Line Current Measurement

The currents produced by the S and DG to the distribution network are continuously monitored. Under normal operating conditions, the vector sum of the currents of the generation system (S and DG's) should be equal to the currents demanded by the loads. Otherwise, two situations can occur: (a) The system is in overload. In this case, the method proposed waits a certain time to see if the overload disappears, and if not, loads are shed. (b) The other situation is that the system is at fault, when a short circuit occurs, the vector sum of the current of the generation system will be a great deal larger than the currents demanded by the loads. The section containing the fault causing the short circuit then needs to be identified as soon as possible. The method begins the localization sequence in section $J = 1$ (the first

section in the table registered in the off-line situation) taking into account the measured injected currents by generation source (S and DG's). It then compares the real measured short circuit current provided by the source to the fault with that recorded for $J = 1$ in the off-line study. This process is repeated for each section and each source. The section where the fault lies can then be identified since the value of the measured current ($I_{cc(x)}$) lies, for all generation sources, between the values of the short circuit currents tabulated in the off-line situation ($I_{cc(i)}$ and $I_{cc(j)}$) corresponding to the nodes at the extreme of the affected section

$$I_{cc(i)} < I_{cc(x)} < I_{cc(j)}, \quad (4)$$

where $I_{cc(i)}$ represents the current that S and DG provide to the short circuit in node i , $I_{cc(j)}$ represents the current that S and DG provide to the short circuit in node j , and the short circuit current to locate is represented by $I_{cc(x)}$, x is the location of the fault at the network, previously unknown.

This step identifies the section where the fault lies through the generation of matrices with the values of the short circuit currents for all types of fault: 3 \emptyset , 2 \emptyset , 2 \emptyset -G and 1 \emptyset -G, restrictions depicted in (5) to (8):

1. for three-phases short circuit 3 \emptyset

$$\begin{aligned} \left[I_{3\emptyset(n,K)} \right]_{(Node\ i)}^{OFF-LINE} &< \left[I_{3\emptyset(n,K)} \right]_{(Node\ X)}^{ON-LINE} < \\ &< \left[I_{3\emptyset(n,K)} \right]_{(Node\ J)}^{OFF-LINE}, \end{aligned} \quad (5)$$

2. for bi-phasic short-circuit 2 \emptyset

$$\begin{aligned} \left[I_{2\emptyset(n,K)} \right]_{(Node\ i)}^{OFF-LINE} &< \left[I_{2\emptyset(n,K)} \right]_{(Node\ X)}^{ON-LINE} < \\ &< \left[I_{2\emptyset(n,K)} \right]_{(Node\ J)}^{OFF-LINE}, \end{aligned} \quad (6)$$

3. for two-phase ground fault 2 \emptyset -G

$$\begin{aligned} \left[I_{2\emptyset-G(n,K)} \right]_{(Node\ i)}^{OFF-LINE} &< \left[I_{2\emptyset-G(n,K)} \right]_{(Node\ X)}^{ON-LINE} < \\ &< \left[I_{2\emptyset-G(n,K)} \right]_{(Node\ J)}^{OFF-LINE}, \end{aligned} \quad (7)$$

4. for single-phase ground fault 1 \emptyset -G

$$\begin{aligned} \left[I_{1\emptyset-G(n,K)} \right]_{(Node\ i)}^{OFF-LINE} &< \left[I_{1\emptyset-G(n,K)} \right]_{(Node\ X)}^{ON-LINE} < \\ &< \left[I_{1\emptyset-G(n,K)} \right]_{(Node\ J)}^{OFF-LINE}, \end{aligned} \quad (8)$$

where n is the number of nodes of radial distribution network and K is the number of generating sources.

The continued flow diagram is depicted in Fig. 4. In a real situation, the fault is isolated by sending the order to open the breakers nearest to the nodes (n_i , n_j) at the extremes of the affected section, and if required the switching out of the DG units connected to the zone.

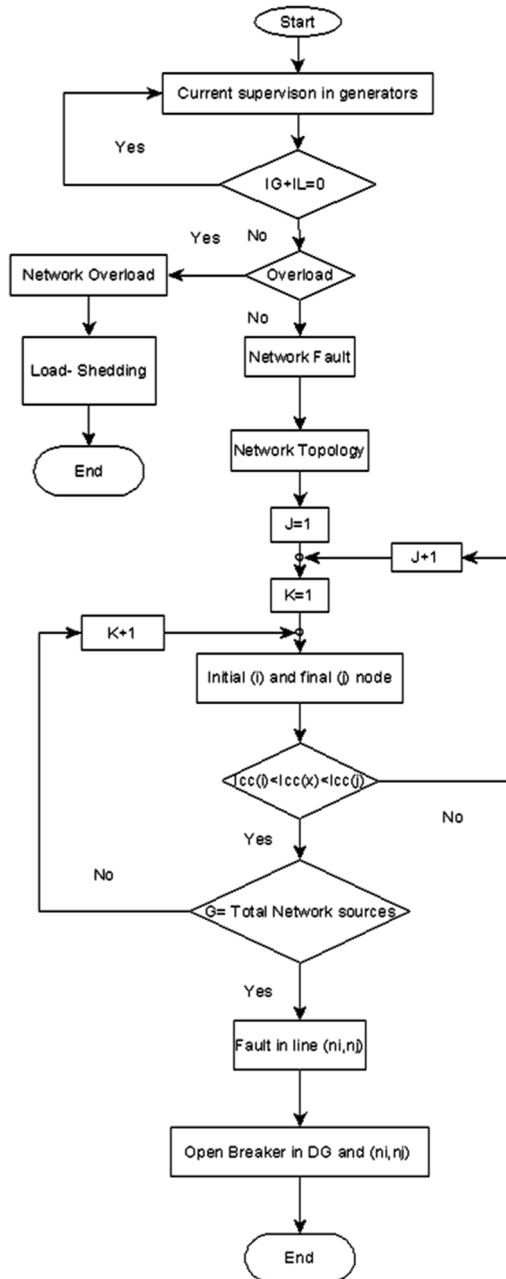

Fig. 4. Proposed method fault detection through on-line current measurement step.

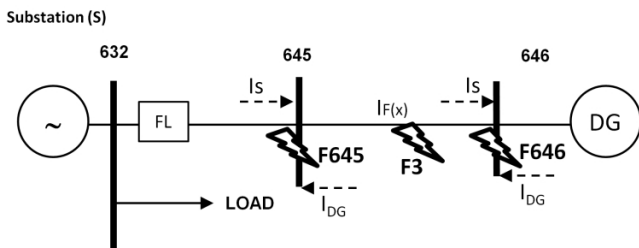

Fig. 5. Fault Localizer (FL) in protection zone.

Using Fig. 5 as an example, for a fault that occurs in F3 any distribution network, the value of the short circuit current $I_{F(x)}$ which is the sum of the currents supplied by S and DG ($I_{F(x)} = I_s + I_{DG}$) will be between the values of short-circuit currents of the end nodes (645 and 646) also sum of the intensities contributed by S and DG. The off-line study would register the values of fault currents contributed by S and DG at node 645 (F645) and 646 (F646), when failure

occurs, the real-time values of the intensities I_s and I_{DG} will find included between tabulated in the offline study (Fig. 3) values and can clearly identify the section of the distribution network that has taken place shortcircuit and properly clear it using the clean command opening end breakers, in this case 645 and 646.

The “binocular view” of a fault’s location derives from the fact that there are always at least two points of the system that provide measured injected currents: the Substation and the DG units.

IV. SIMULATION RESULTS

The method was tested using the IEEE 13-node test feeder system [20]. A simulated radial network was divided into different protection zones as shown in Fig. 6, which shows the distribution network used. The study was performed in the zones 1, 2 and 3, e.g. those with functioning DG units.

The electrical faults (F1,F2,...,F15) simulated to test the method were three phase (3Ø), bi-phase to ground (2Ø-G), bi-phase (2Ø) and single phase to ground (1Ø-G), being 50 the total study cases simulated. All these were simulated using DlgSILENT software (PowerFactory) [21], as it is shown in Fig.6. This software has a toolbox specific for studies on the coordination of protection and short circuits in electrical distribution networks. The tested method was programmed using MATLAB [22]. In this study the arc resistance it is not considered, it will be proposed for future works.

The IEEE 13-node network was supplied with a transformer 5 MVA. The voltage was 45/15 kV at node 632. The DG generators contemplated were synchronous generators. The Table II shows the load characteristic network study, the total load of the system was 3.83 MW.

TABLE II. CHARACTERISTIC LOAD OF THE NETWORK.

Node	Load (Mw)
634	1.5
645	0.056
646	0.5
652	1
671	0.385
675	0.281
692	0.056
611	0.056

The length of the lines is shown in Table III, where topology network was overhead.

TABLE III. LENGTH OF THE LINES OF THE NETWORK.

Node A	Node B	Length(m)
632	645	1500
632	633	1500
633	634	1000
645	646	900
632	671	6100
671	680	300
671	684	900
671	692	1500
684	611	200
692	675	150

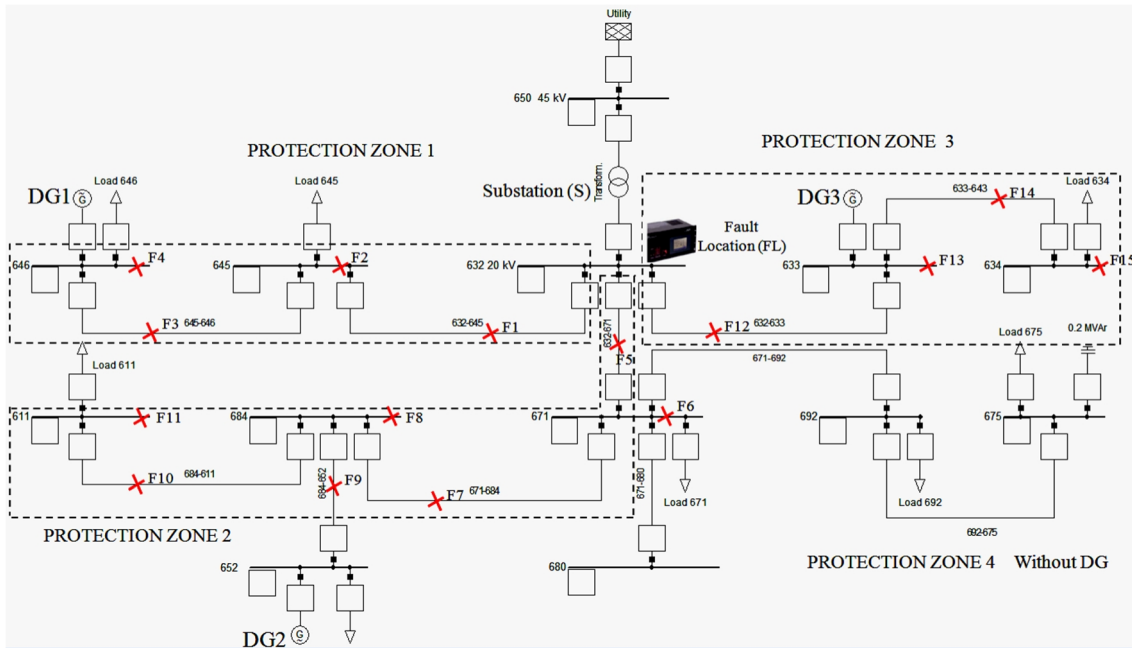

Fig. 6. Protection zones within a simulated radial network used to test the proposed method of fault location.

A. Case study: Protection Zone 2

The results presented here are those for protection zone 2, the most complex of the simulated network, and for the 3Ø and 1Ø-G faults (the most severe and the most common respective).

In protection zone 2, the DG unit was installed at node 652 (Fig. 7). The agent with the running method was installed in the substation at node 632, and monitored the currents provided by the substation (S) and the DG unit. Zone 2 was composed of four nodes (632, 671, 684 and 611) and three line sections.

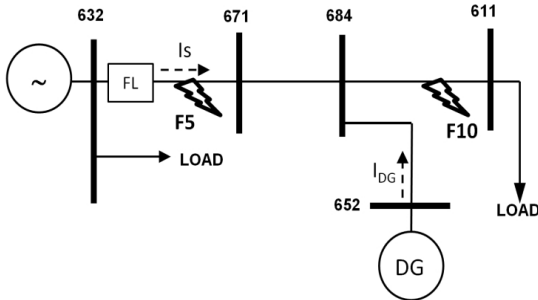

Fig. 7. Fault Localizer (FL) in protection zone 2.

In this scenario, the currents monitored from both sources, and the load demanded were $I_S = 0.08$ kA, $I_{DG} = 0.04$ kA, and $I_{LOAD} = 0.12$ kA. DG installed: 1 MW.

Table IV shows the short circuit currents recorded for the 3Ø and Ø-G fault conditions in the off-line study.

In networks with a rigid earth (such as the present), or with an earth via a low impedance, the condition $\varphi_1 - \varphi_0 \leq 30$ [22] (where φ_1 is the angle of direct impedance Z_1 , and φ_0 is the angle of homopolar impedance Z_0) is usually met. Thus, the short circuit current in a Ø-G fault is greater than that in a 3Ø fault, as Table IV shows.

Table V shows the value of the currents monitored by the algorithm with the running method when the system is stable, and when 3Ø and Ø-G faults occur in the on-line situation for each of the sections in protection zone 2.

TABLE IV. CURRENTS SUPPLIED BY THE GENERATING SOURCES TO THE FAULT (FAULT IN THE NODE CONSIDERED, 632, 671, 684 OR 611). OFF-LINE STUDY.

	Bus	632	671	684	611
3Ø	I_S (kA)	$a_{11}=1.582$	$a_{21}=1.091$	$a_{31}=1.033$	$a_{41}=0.966$
	I_{DG} (kA)	$a_{12}=0.423$	$a_{22}=0.462$	$a_{32}=0.465$	$a_{42}=0.440$
1Ø-G	I_{SE} (kA)	$a_{11}=2.082$	$a_{21}=1.27$	$a_{31}=1.194$	$a_{41}=1.090$
	I_{DG} (kA)	$a_{12}=0.470$	$a_{22}=0.558$	$a_{32}=0.567$	$a_{42}=0.520$

Note: I_S , current supplied by the substation. I_{DG} , current supplied by the DG unit.

TABLE V. CURRENTS SUPPLIED BY THE GENERATING SOURCES TO THE FAULT IN PROTECTION ZONE 2. POSSIBLE ON-LINE SITUATIONS DEFINED BY THE I_S AND I_{GE} CURRENTS MEASURED IN A REAL SITUATION.

	S	kA	State	Fault section	Open breaker	Open DG
Stable	I_S	0.082	Stable	-	-	-
	I_{DG}	0.043	Stable	-	-	-
3Ø	I_S	1.315	Fault	632-671	632-671	652
	I_{DG}	0.447				
	I_S	1.069	Fault	671-684	671-684	652
	I_{DG}	0.460				
	I_S	0.993	Fault	684-611	684-611	652
	I_{DG}	0.457				
1Ø-G	I_{SE}	1.615	Fault	632-671	632-671	652
	I_{DG}	0.512				
	I_S	1.236	Fault	671-684	671-684	652
	I_{DG}	0.563				
	I_S	1.140	Fault	684-611	684-611	652
	I_{DG}	0.542				

Thus, for a fault occurring in protection zone 2, the agent with the running method compares (in real time) the currents supplied by the substation (S in Fig. 6) and the DG with the currents supplied by the same elements in the off-line situation in the sections 632-671, 671-684, and 684-611. The isolation of the fault would require the swift ordering of the breakers at the nodes at the ends of the affected section, plus the opening of the corresponding DG breaker, to avoid the latter's isolated functioning.

Thus, in a real situation, any fault to produce different short circuit currents, the proposed methodology, which

measures the currents supplied by S and the DG units, would allow the fault to be pinpointed. This would not be possible if only the currents supplied by the main feeder of the grid (S) were measured. The concept is akin to binocular vision: with binocular vision one can calculate distances, whereas with monocular vision one cannot. The situations described by Wan *et al.* [14], which they insisted could not be coordinated by existing methods, could be resolved with that proposed.

The present results also show that the method could also be used if the affected sector had more than one DG, as long as the currents from each are measured. Logically, as the number of points of measurement increases, so does the method's reliability, although some calculations are likely to be redundant. The method could be routinely used by electrical companies if they were to install even very small DGs at the end of sections.

The limitation of the method lies in the speed of the communications system; speeds that can cover t_1 , t_2 and t_3 (see Section I) are needed if a response to a short circuit is to be made quickly enough. Otherwise, the method proposed is simple, and the required processing time (milliseconds) adds no significant lag to the overall process of detection and reaction; indeed it is quicker than any method based on phase components.

V. CONCLUSIONS

This study proposes a new method for the location of faults in electrical networks involving DG. The method uses the IEEE 13-node test feeder system: a simulated radial network which is divided into different protection zones. The tests are performed in the protection zone 2 because it is the most complex zone, and for the 3 \emptyset and 1 \emptyset -G faults (the most severe and the most common respectively).

The tested method is programmed using MATLAB and this algorithm locate the faults sections correctly, both in the 3 \emptyset and 1 \emptyset -G faults. The fault section is located in function of the values of the currents injected by the S and the DG. For instance, in the case of 3 \emptyset fault, $I_S = 0.993$ kA and $I_{DG} = 0.457$ kA indicated that the fault section was 684-611 and commanded the breakers 684-611 to open and the DG 652 to disconnect (Table V).

The method used requires no knowledge of the impedances along power lines for the fault to be detected for the affected section to be isolated, or for the DG in the protection zone to be switched out. All that is required is that the topology of the network be known. It only requires that at least one DG unit be functioning within the sector where the fault lies (if all were off-line then conventional methods of fault location would be required), and a communications network in place that is fast enough to allow good coordination between protection devices (a limitation common to all protection coordination systems that use communications networks). To be functional, however, it does require an adequate communication system connected to the installed protection devices on lines and in substation transformers. Determining the currents supplied to the fault by the main

feeder of the grid and DG units provides a "binocular view" of a fault's location.

Finally, future researches to continue the present work, may include several values of the arc resistance in the Binocular Method to locate single faults.

REFERENCES

- [1] T. Vainmann, J. Niitsoo, T. Kivipold, T. Lehtla, "Power quality issues in dispersed generation and smart grids", *Elektronika ir elektrotechnika*, vol. 18, no. 8, pp. 23–26, 2012. [Online]. Available: <http://dx.doi.org/10.5755/j01.eee.18.8.2605>
- [2] A. T. Johns, L. L. Lai, M. El-Hami, D. J. Daruvala, "New approach to directional fault location for overhead power distribution feeders", *IEEE Proc.*, vol. 138, no. 4, pp. 351–357, 1991.
- [3] T. Takagi, Y. Yamakoshi, Yamaura, R. Kondow, T. Matsushima, "Development of a new type fault locator using the one-terminal voltage and current data", *IEEE Trans. Power Apparatus and Systems*, vol. 10, pp. 2892–2898, 1982. [Online]. Available: <http://dx.doi.org/10.1109/TPAS.1982.317615>
- [4] A. Girgis, C. Fallon, D. Lubkerman, "A fault location technique for rural distribution feeders", *IEEE Trans. Industry and Applications*, vol. 26, no. 6, pp. 1170–1175, 1993. [Online]. Available: <http://dx.doi.org/10.1109/28.259729>
- [5] K. Srinivasan, A. St-Jacques, "A new fault location algorithm for radial transmission lines with loads", *IEEE Trans. Power Delivery*, vol. 4, no. 3, pp. 1676–1682, 1989. [Online]. Available: <http://dx.doi.org/10.1109/61.32658>
- [6] R. Das, "Estimating locations of shunt faults on distribution lines", MSc Thesis, College of Graduate Studies and Research, Univ. of Saskatchewan, Saskatchewan, 1995.
- [7] R. Das, M. Shadev, T. S. Sidhu, "A technique for estimating locations of shunt faults on distribution lines", in *Conf. Proc. IEEE WESCANEX*, vol. 1, 1995, pp. 6–11. [Online]. Available: <http://dx.doi.org/10.1109/wescan.1995.493936>
- [8] L. Yang, "One terminal fault location system that corrects for fault resistance effects", *US Patent number 5,773,980*, 1998.
- [9] Y. Gong, A. Guzman, "Integrated fault location system for power distribution feeder", *IEEE Trans. Industry and Applications*, vol. 49, no. 3, pp. 1071–1078, 2013. [Online]. Available: <http://dx.doi.org/10.1109/TIA.2013.2252596>
- [10] S. Jamali, V. Talavat, "Dynamic fault location method for distribution networks with distributed generation", *Journal of Electrical Engineering*, vol. 92, no. 3, pp. 119–127, 2010. [Online]. Available: <http://dx.doi.org/10.1007/s00202-010-0169-z>
- [11] H. Wan, K. Li, K. Wong, "An multi-agent approach to protection relay coordination with distributed generators in industrial power distribution system", *IEEE Trans. Industry and Applications*, vol. 46, no. 5, pp. 2118–2124, 2010. [Online]. Available: <http://dx.doi.org/10.1109/TIA.2010.2059492>
- [12] B. Deck, M. Naedele, "IT Security for utility automation systems", *CIGRE 2004*, paper B5-105.
- [13] J. Curk, I. Kobal, G. Parkelj, "Modern IT Technology improves substation control and protection systems architecture", *Power System Protection Conf.*, vol. 1, pp. 41–45, 2004.
- [14] H. Wan, K. Li y K. Wong, "Multi-agent application of substation protection coordination with distributed generators", *Int. Conf. Future Power Systems*, pp. 1–6, 2005.
- [15] IEC 61850. "Communication networks and systems in substations". 2005.
- [16] A. Apostolov, "Communications in IEC 61850 based substation automation systems", *Conf. Power Systems: Advanced Metering, Protection, Control, Communication, and Distributed Resources*, pp. 51–56, 2006.
- [17] P. Lloret, J. L. Velasquez, L. Molas-Balada, "IEC 61850 as a Flexible tool for electrical systems monitoring", *9th Int. Conf. Electrical Power Quality and Utilisation*, 2007. [Online]. Available: <http://dx.doi.org/10.1109/epqu.2007.4424193>
- [18] P. M. Anderson, *Power System Protection*. Wiley-IEEE Press, 1998, pp. 147–197.
- [19] P. M. Anderson, *Analysis of Faulted Power*. IEEE Press, 1995.
- [20] The Institute of Electrical and Electronics Engineers, "IEEE: 13 Node Test Feeder", 2004.
- [21] DiGSILENT PowerFactory, User's Manual. Version 14.0, 2008.
- [22] Matlab.R2008a, *The Language of Technical Computing*.
- [23] R. Roeper, *Corrientes de cortocircuito en redes trifásicas*, Marcombo, 1985, pp. 59–90.