

## The Sensitivity of the Fractal Spectrum: a Means of Controlling the Statistical Properties of Chaotic Signals

**R. Ursulean**

*Faculty of Electrical Engineering, "Gh. Asachi" Technical University,  
Bd. D. Mangeron 53, Iasi 700050, Romania, e-mail: ursulean@ee.tuiasi.ro*

**A. M. Lazar**

*Faculty of Bioengineering, "Gr. T. Popa" Medicine and Pharmacy University,  
Str. Universitatii nr. 16, Iasi, 700115, Romania, e-mail: anca.lazar@bioinginerie.ro*

**M. Istrate**

*Faculty of Electrical Engineering, "Gh. Asachi" Technical University,  
Bd. D. Mangeron 53, Iasi 700050, Romania, e-mail: mistrate@ee.tuiasi.ro*

**crossref** <http://dx.doi.org/10.5755/j01.eee.114.8.688>

### Introduction

There are a few reasons why non-linear electronic circuits are used as sources for pseudorandom signals, among them being their simplicity and robustness, not to mention the continuous signal obtained from their output. There were quite a lot of attempts to develop non-linear circuits that exhibit chaotic behaviour since the introduction of the well known (and analysed) one, Chua's circuit [1]. They were based on simple resistor-inductance-diode (RLD) circuits [2, 3] or just resistor-capacitor (RC), [4–7], to mention just a few.

Nevertheless, only a small number of these circuits were tested as pseudorandom number generators, like the ones in [8] and [9]. When used for cryptographic applications, pseudorandom number generation is obtained via computer simulations of the equations describing the chaotic systems themselves.

Some limitations must be taken into account when dealing with non-linear circuits that exhibit chaotic behaviour, used as pseudorandom number generators, because they drastically restrict the number of candidates for the task. First, a good premise for adequate statistical properties is obtained when the generated signal has high entropy, [10]. Another one is the very long period of a signal obtained for testing purposes by means of computer simulation. There is a third groundwork that could lead to acceptable statistical properties, namely a high correlation dimension, seen as a measure of the chaotic properties of the signals.

Since none of the existing circuits was originally developed for such purposes, we intend to evidence the associations between the circuit's elements and its chaotic properties. This could lead to a better perception of these

circuits, when used as pseudorandom signal generators. It is well understood that adequate chaotic properties are a good premise for statistical ones. We suggest the sensitivity of the fractal spectrum of the chaotic signals, due to the circuit components, as a new instrument used to influence the chaotic behaviour in the desired way. As an example, a modified Wien-bridge oscillator is analysed from this point of view.

In the next section, we establish the definition of the sensitivity of the fractal spectrum of a chaotic signal in relation to any circuit element, while the third one briefly presents the modified Wien-bridge circuit and the results of the simulations; the last one is devoted to the conclusions of our study, while the appendix is committed to the mathematical background for the algorithm used to compute the Rényi entropy.

### The sensitivity of the fractal spectrum

Common practice is to characterise the output signal of a non-linear circuit that exhibits chaotic behaviour, by determining its correlation dimension. In fact, the correlation dimension belongs to an infinite family of fractal dimensions, as shown for the first time in [11]. Due to this observation, it is hopeful to try to characterise such signals by the whole family of fractal dimensions, known as the fractal spectrum, instead of using just some of them. We shall try to do so by means of a relatively new axiomatic theory of probability, introduced by Rényi in [12].

In what follows, we plan to investigate some non-linear circuits that are capable of generating chaotic signals. For this purpose, a measure of the influence of each component of the circuit on the chaotic signal that is

generated is needed, since we intend to show the inner links between the parameters of the signal and the elements of the circuit. For this reason we define the sensitivity of the fractal spectrum, denoted by FS, relative to each circuit component as

$$S_Z^{FS} = \Delta FS / \Delta Z = (FS - FS_n) / (Z - Z_n), \quad (1)$$

where Z becomes R [Ohms] for a resistor, C [Farads] for a capacitor and L [Henrys] for a coil of inductance L.

The fractal spectrum is computed in accordance with the two generalized fractal dimensions, denoted by  $D_{-\infty}$  and  $D_{\infty}$

$$FS = D_{\infty} - D_{-\infty}, \quad (2)$$

as presented in the Appendix.

If by  $FS_n$  we designate the value of the fractal spectrum computed for the circuit when all the elements have their nominal values, (denoted by  $R_n$ ,  $C_n$  and  $L_n$ ), we have a possibility of defining a normalised value of the above sensitivity, as follows

$$SN_Z^{FS} = \frac{\Delta FS}{\Delta Z} = \frac{\Delta FS}{\Delta Z} \cdot \frac{Z_n}{FS_n}, \quad (3)$$

where FS and Z are the actual values.

The above definition gives a value that is dimensionless and this makes comparisons between sensitivities due to different circuit elements possible, regardless of their nature.

### The modified Wien-bridge oscillator as a chaotic signal generator

The Wien-bridge oscillator is a widely used circuit configuration, because RC oscillators are simpler and more convenient at low frequencies than their LC counterparts. Some of the realisations of such oscillators may be found in [13–17]. In what follows, we shall focus only on the circuit given in [15], due to its simplicity and ease of analysis and to its good stability of chaotic oscillations.

The circuit presented in Fig. 1 consists of two operational amplifiers: A1 which is the Wien-bridge oscillator and A2, which acts as a negative impedance converter (NIC) at higher levels of voltage on the capacitor C3, (see [15] for the in-depth of the functioning). Nevertheless, we shall mention that two conditions must be fulfilled to adjust the circuit to the chaotic mode of oscillation: 1) by modifying the gain of the first operational amplifier A1, e.g. fine-tuning R3 and/or R4 and 2) R8 must always be smaller than R6 to obtain the functioning of the second operational amplifier as a negative impedance converter.

The standard circuit has the following nominal values for its components:  $R1=R2=11k\Omega$ ,  $R3=7.9k\Omega$ ,  $R4=2k\Omega$ ,  $R5=R7=2.7k\Omega$ ,  $R6=1.1k\Omega$ ,  $R8=780\Omega$ ,  $C1=C2=C3=1.3nF$ ,

D is 1N914, A1 and A2 are LM741. In what follows, these values will be considered nominal according to the above definition, (3).

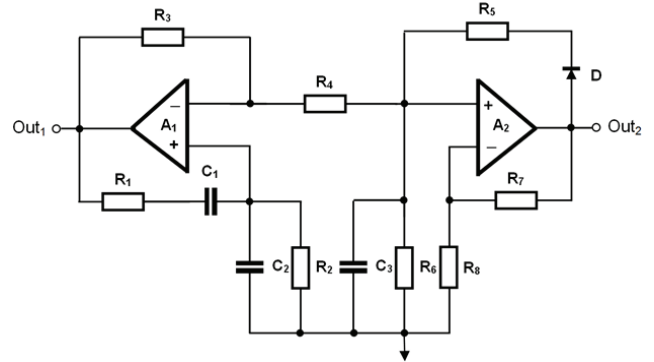


Fig. 1. The modified Wien-bridge circuit

The typical voltage vs. time graphs for the outputs Out1 and Out2, during the steady-state for the above circuit, are presented in Fig.2 and Fig.3. The output values were translated into the [0,1] interval for both outputs, to allow an easier and better evaluation.

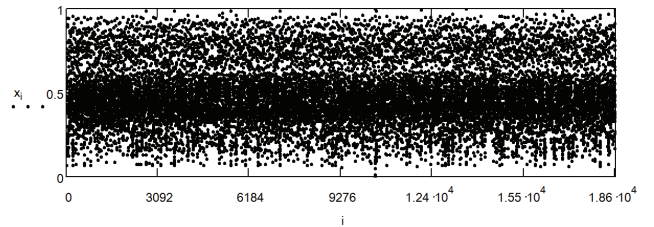


Fig. 2. Voltage at Out1 vs. time (in milliseconds)

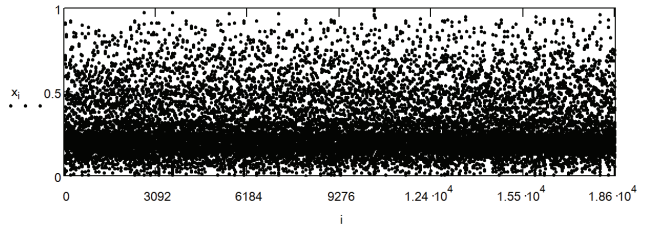
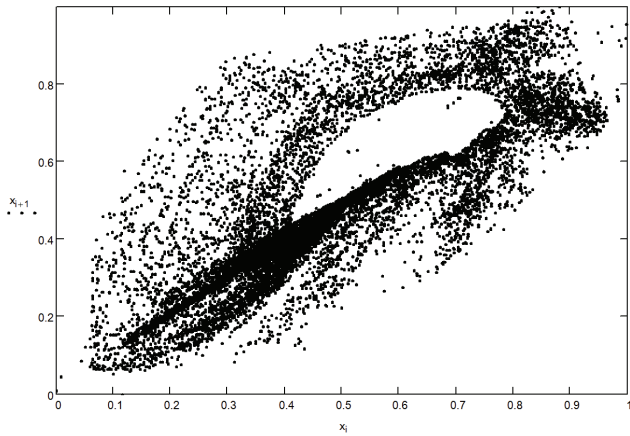


Fig. 3. Voltage at Out2 vs. time (in milliseconds)

The above graphs, presented as dots to emphasise the “filling” of the [0,1] interval, clearly show that the distribution of the signal is not a uniform probability density function, as expected, [9]. Nevertheless, this may be solved since one may take into account just a fraction of the time series, the one that lies in a narrower voltage interval, where the distribution is uniform. The price paid for this is a longer time needed to generate the desired number of samples because sometimes the signal lies outside the desired interval.

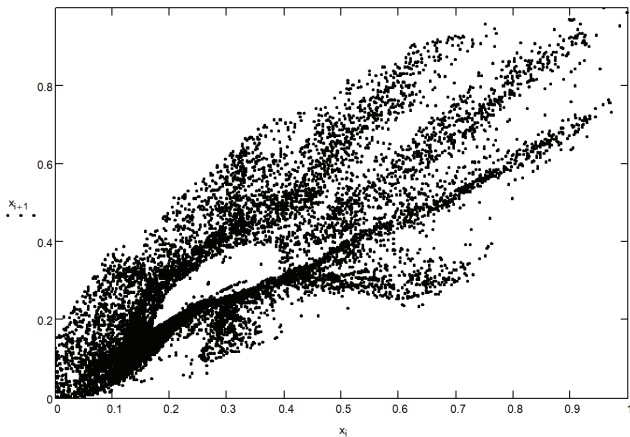
The phase portraits for the outputs of the standard circuit are presented in Fig. 4 and Fig. 5.

The phase portraits are quite different and as a result, the statistical properties of the chaotic signals are expected to be different too. From this point of view, the outputs exhibit different probability density functions, as shown in Fig. 6 (for Out1) and 7 (for Out2).

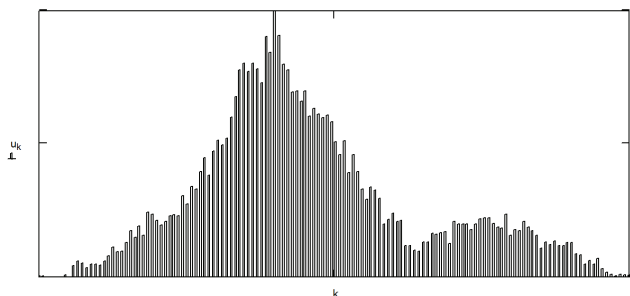


**Fig. 4.** Phase portrait for Out1

Both histograms are highly asymmetric and display clear modes, more evidenced for the second output. For this reason, their use as uniformly distributed pseudo-random numbers is impossible, considering the whole interval for the output voltages. The asymmetry was induced by the fact that the second operational amplifier, A2, is activated only when high levels of voltage across R6 and C3 are reached. However, the normal repartition was generated for R3=8k $\Omega$  and R4=2.1 k $\Omega$  (these resistors are used to modify the gain of the first operational amplifier) and only for this instance the statistical quality was far better for the signal of the output Out<sub>1</sub>.



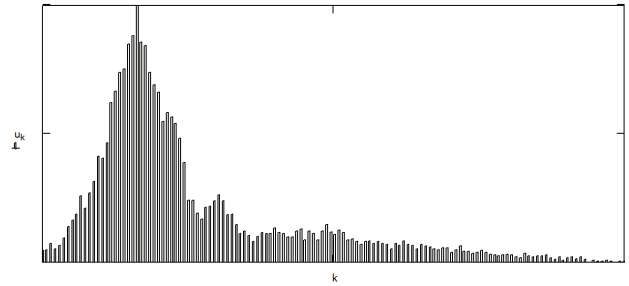
**Fig. 5.** Phase portrait for Out2



**Fig. 6.** Histogram for the signal at Out1

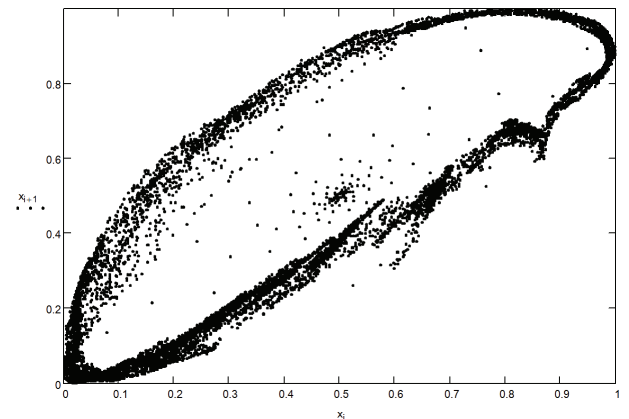
In fact, the above observation is emphasised if we notice the normalised sensitivity of the fractal spectrum due to the influence of the two resistors that are among the

greatest (e.g. 12.67 for 10% change in the value of R3).

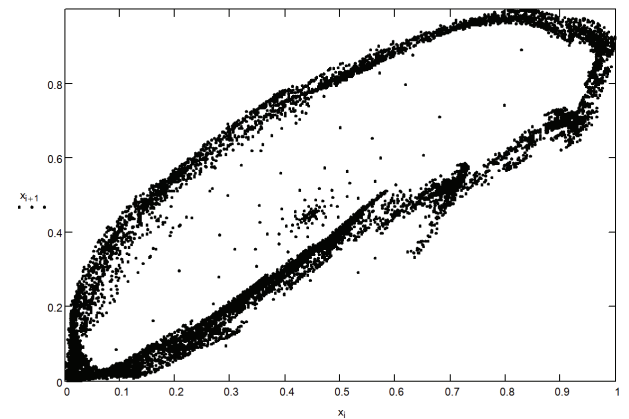


**Fig. 7.** Histogram for the signal at Out2

Changing the value of R6 plays a major role and provides a good example of the way in which the probability density function could possibly be transformed. The figures 8 to 11 give the phase portraits and the histograms of the outputs when the value of the resistor R6 is modified from the nominal value of 1.1k $\Omega$  to 1.8k $\Omega$  and the rest of the components remain unchanged. It is also worth noticing the fact that the phase portraits for both outputs look the same and for that reason the histograms also appear similar. Still, the probability density function has significantly changed, compared to the one of the standard circuit. Unfortunately, only for this case the outputs were nearly identical, because the rest of the simulations showed greater differences between the outputs when other circuit elements were modified.



**Fig. 8.** Phase portrait for Out1 (R6=1.8k $\Omega$ )



**Fig. 9.** Phase portrait for Out2 (R6=1.8k $\Omega$ )

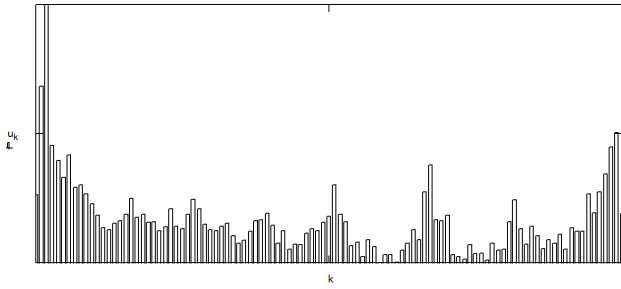


Fig. 10. Histogram for Out1 (R6=1.8kΩ)

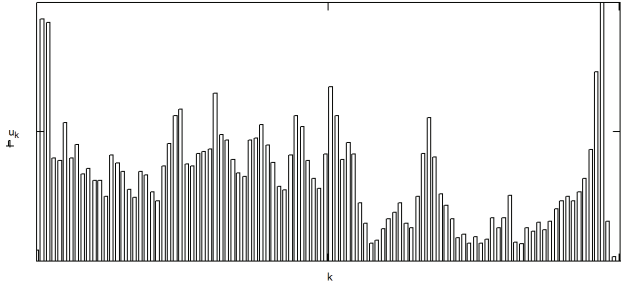


Fig. 11. Histogram for Out2 (R6=1.8kΩ)

To quantify the chaotic properties, the fractal spectrum was computed for different values of the circuit components. The transients were omitted and the value of  $\Delta x$  (see the appendix) was chosen  $10^{-3}$  volts, which proved to be a good compromise between the computing time and the precision needed. The fractal spectra for both outputs are presented in Fig. 12. The major contribution in changing the fractal spectrum was given by the gain of the A1 operational amplifier (and hence by R3 and/or R4) and the voltage threshold for the negative impedance converter, introduced by R6.

As a general observation, the signal Out<sub>2</sub> had a greater range of correlation dimensions in every instance, making it a better candidate for the generation of the pseudorandom numbers.

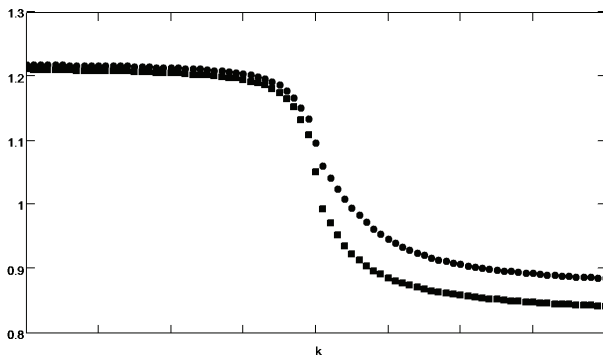


Fig. 12. The fractal spectra for the standard circuit (Out1 – square, Out2 – circle)

The mean of the difference  $D_{-\infty} - D_{\infty}$  for the first output was 0.342 and 0.402 for the second, which also indicates the second output as a better choice from the chaotic properties' point of view. Even the greatest value of the difference  $D_{-\infty} - D_{\infty}$ , 0.523, was obtained for R6=1.8kΩ, as well as for the second output. The full results are provided in Table 1.

Table 1. Fractal spectrum values

	Fractal spectrum values ( $D_{-\infty} - D_{\infty}$ )		
	Minimum	Maximum	Mean
Out <sub>1</sub>	0.29	0.481	0.342
Out <sub>2</sub>	0.337	0.523	0.402

The sensitivities of the fractal spectrum for the two outputs were computed for different values of the elements. The signal at the Out<sub>1</sub> output proved to have a fractal spectrum more sensitive to the variations of the circuit elements than the one of the Out<sub>2</sub> output. The extreme values for the sensitivities and the circuit elements involved in obtaining them are presented in Table 2. The minus signs are used as indicators for different directions of variation for the fractal spectrum and for the circuit elements concerned.

Table 2. Fractal spectrum sensitivity

	Fractal spectrum sensitivity	
	Minimum value/ due to circuit element	Maximum value/ due to circuit element
Out <sub>1</sub>	0.04/R6	3.18/C1
Out <sub>2</sub>	-0.027/R6	-2.33/C1

It is worth noticing that the sensitivities may be computed as long as the circuit behaves chaotically and this reduces the interval of variation for the circuit elements somewhat. As a general rule, all the sensitivities that contained capacitors were significantly lower than the ones that involved resistors.

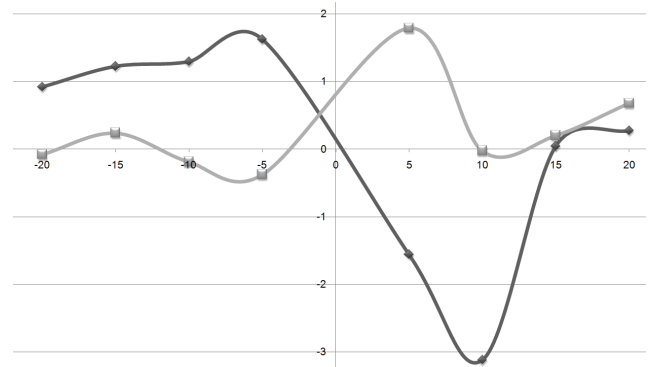


Fig. 13. Normalised sensitivities of Out1 (dark line) and Out2 (light line) versus percent changes in R6

Since the R6 resistor played the main role in establishing the nature of the signal at both outputs, in Fig. 13 the normalised sensitivities of the fractal spectrum of both outputs versus percentage change in the value of R6 are presented.

## Conclusions

The possibility of using a class of Wien-bridge based chaotic oscillators as pseudorandom number generators was investigated using a method involving the fractal spectrum, computed by means of the Rényi entropy. The results showed that for the circuit described, the quality of the signals, from the statistical point of view, was determined by the gain of the Wien-bridge oscillator and

the resistor that establishes the threshold for the negative impedance converter.

It was also revealed that it is possible to change the probability density function by simply adjusting the voltage threshold for the negative impedance converter and the fact that the signals from the two possible outputs are not the same from the statistical and the chaotic properties point of view.

The newly introduced sensitivities of the fractal spectrum relative to the circuit elements showed that due to their significant values in the case of the resistors that establish the gain of the circuit, trying to “tune” the circuit to chaos proves to be efficient, but with bad consequences for the statistical quality of the pseudo-random numbers generated from the output signal of the circuit.

## Appendix

Using the definition for the generalized entropy and based on the moments of order  $r$  of the probability  $p_i$ , the entropy, according to Rényi, [12], is given by

$$S_r = \frac{1}{1-r} \log_2 \sum_{k=1}^n p_k^r \quad (4)$$

with  $r \in \mathbb{R} - \{1\}$  and  $p_i \in [0,1]$ .

The above formula assumes that the probability distribution function is known beforehand. Unfortunately, this is not the case when dealing with circuits that generate chaotic signals. Therefore, one must develop a “counting” procedure, as follows: if the minimum and the maximum values of the signals are denoted by  $x_{\min}$  and  $x_{\max}$  and  $\Delta x$  is the smallest variation of the signal that can be evidenced, then  $n$ , the number of intervals used in the counting process is

$$n = \left[ \frac{x_{\max} - x_{\min}}{\Delta x} \right], \quad (5)$$

where  $[x]$  denotes the integer part of  $x$ . Let  $n_k$  be the number of times the signal falls into the  $k$ -th interval; this probability may be estimated as

$$p_k = \frac{n_k}{n}. \quad (6)$$

Knowing the above probabilities, the generalised fractal dimension of order  $r$  may be written as follows

$$D_r = \frac{1}{1-r} \cdot \frac{\log_2 \sum_{k=1}^n p_k^r}{\log_2 \Delta x} \Bigg|_{\Delta x \rightarrow 0}. \quad (7)$$

For a given probability distribution, the generalised fractal dimension  $D_r$ , which is a non-increasing function of  $r$ , is named fractal spectrum; it provides information concerning both the amplitudes and the frequency of the analysed signal. It is worth noticing the following

particular cases, in fact two limit cases,  $r = -\infty$  and  $r = \infty$ , when the fractal dimension becomes:

$$D_{-\infty} = \frac{\log_2 p_{\min}}{\log_2 \Delta x} \Bigg|_{\Delta x \rightarrow 0} \quad (8)$$

and

$$D_{\infty} = \frac{\log_2 p_{\max}}{\log_2 \Delta x} \Bigg|_{\Delta x \rightarrow 0}, \quad (9)$$

where

$$p_{\max} = \max \{p_k\}, \quad k = \overline{1, n} \quad (10)$$

and

$$p_{\min} = \min \{p_k\}, \quad k = \overline{1, n}. \quad (11)$$

These two cases set the ranges of fractal dimensions and their difference,  $D_{-\infty} - D_{\infty}$ , is a strong indicator for the chaotic behaviour of the signal: the bigger the difference, the better the chaotic properties.

## Acknowledgement

This study was supported by the Romanian Ministry of Education, BCISIS project, under contract # 12115/2008-2011.

## References

1. **Chua L. O.** The genesis of Chua's circuit // *AEÜ*, 1992. – No. 46(4). – P. 250–257.
2. **Linsay P. S.** Period doubling and chaotic behaviour in a driven anharmonic oscillator // *Physical Review Letters*, 1981. – No. 19. – P. 1349–1352.
3. **Sprott J. C.** A new class of chaotic circuit // *Physics Letters*, 2000. – No. A 266. – P. 19–23.
4. **Petrzela J., Hanus S.** Universal structure of RC oscillator and the chaos generation // *Proceedings of the 5th WSEAS Conference on System Science and Simulation Engineering*, 2006. – P. 381–385.
5. **Elwakil A. S., Kennedy M. P.** Construction of classes of circuit independent chaotic oscillators using passive-only nonlinear devices // *IEEE Trans. Circuits Syst.*, 2001. – No. 48. – P. 289–307.
6. **Masuda S., Uchitani Y., Nishio Y.** Simple chaotic oscillator using two RC circuits // *Proceedings of RISP International Workshop on Nonlinear Circuits and Signal Processing (NCSP'09)*, 2009. – P. 89–92.
7. **Hosokawa Y., Nishio Y.** Analysis of chaotic circuits using Wien bridge oscillator and a resonator // *Proceedings of RISP International Workshop on Nonlinear Circuits and Signal Processing, (NCSP'05)*, 2005. – P. 73–76.
8. **Yalcin M. E., Suykens J. A. K., Vandewalle J.** True random bit generation from a double-scroll attractor // *IEEE Trans. on Circuits Syst. I*, 2004. – No. 51. – P. 1395–1404.
9. **Nakaaji Y., Aono S., Nishio Y.** Run test of pseudo-random numbers generated by chaotic maps // *Proceedings of RISP International Workshop on Nonlinear Circuits and Signal Processing (NCSP'05)*, 2005. – P. 57–60.

10. **Kantz H., Olbrich E.** Coarse grained dynamical entropies – investigation of high-entropic dynamical systems // *Physica A*, 2000. No. 280. – P. 34–48.
11. **Hentschel H. G. E., Procaccia I.** The infinite number of generalized dimensions of fractals and strange attractors // *Physica D*, 1983. – No. 8. – P. 435–444.
12. **Rényi A.** On a new axiomatic theory of probability // *Acta Math.*, 1995. – No. 6. – P. 285–335.
13. **Morgul O.** Wien-bridge based RC chaos generator // *Electron. Lett.*, 1995. – No. 31. – P. 2058–2059.
14. **Namajunas A., Tamasevicius A.** Modified Wien-bridge oscillator for chaos // *Electron. Lett.*, 1995. – No. 31. – P. 335–336.
15. **Namajunas A., Tamasevicius A.** Simple RC chaotic oscillator // *Electron. Lett.*, 1995. – No. 32. – P. 945–946.
16. **Tamasevicius A., Mykolaitis G., Cenys A.** Wien-bridge chaotic circuit with comparator // *Electron. Lett.*, 1998. – No. 34. – P. 606–607.
17. **Mykolaitis G., Tamaševičius A., Bumelienė S., Lasienė G., Čenys A., Lindberg E.** HF and VHF Chaos Oscillators // *Elektronika ir elektrotechnika*. – Kaunas: Technologija, 2001. – No. 3(32). – P. 12–17.

Received 2011 06 03

**R. Ursulean, A. M. Lazar, M. Istrate. The Sensitivity of the Fractal Spectrum: a Means of Controlling the Statistical Properties of Chaotic Signals // *Electronics and Electrical Engineering*. – Kaunas: Technologija, 2011. – No. 8(114). – P. 21–26.**

This paper investigates the possibility of generating pseudorandom numbers by means of non-linear circuits. We intend to demonstrate the links between the circuit elements and the chaotic properties, by defining the sensitivity of the fractal spectrum of the signal related to the elements of the circuit. In this way, the statistical properties and the ability to change them simply by an adequate adjustment of the circuit elements is made possible. To illustrate the method, a modified circuit based on the well known Wien-bridge oscillator is analysed through computer simulation. A study of the influence of the components of this circuit and their impact on the properties of the chaotic signal is also carried out, based on the newly introduced sensitivities. The study showed that not only the main statistical indicators, such as the mean, the standard deviation, the median etc., but even the type of the probability density function can be changed only by means of small variations of certain circuit elements. Ill. 13, bibl. 17, tabl. 2 (in English; abstracts in English and Lithuanian).

**R. Ursulean, A. M. Lazar, M. Istrate. Kontroliuojamų nereguliarių signalų statistinių savybių įtaka fraktalinio spektro jautrumui // *Elektronika ir elektrotechnika*. – Kaunas: Technologija, 2011. – Nr. 8(114). – P. 21–26.**

Nagrinėjami pseudoatsitiktinių skaičių netiesinėse grandinėse vidurkliai. Pateikiamas sąryšis tarp grandinės elementų ir atsitiktinių signalų savybių. Tokiu atveju signalų statistines savybes galima keisti tinkami koreguojant grandinės elementus. Metodo taikymo patikrinimas atliktas modeliuojant grandinę, paremtą Vieno tilteliu. Nustatyta grandinės elementų įtaka nereguliarių signalų savybėms. Il. 13, bibl. 17, lent. 2 (anglų kalba; santraukos anglų ir lietuvių k.).