

Controller with the Set Point Shift of Domestic Water Supply Control System

V. Gobis¹, A. Baskys², V. Zlosnikas^{1,2}, E. Meile^{1,2}, A. Platakis^{1,2}

¹Center for Physical Sciences and Technology,

A. Gostauto St. 11, LT-01108 Vilnius,

²Department of Computer Engineering, Vilnius Gediminas Technical University,
Naugarduko St. 41, LT-03227 Vilnius, Lithuania

Abstract—The controller for domestic water supply feedback control system is developed and analyzed. It allows us to improve the control quality and save the energy consumed by the pump drive as compared to the case when PI controller is used. The simulation results of the control system are presented and discussed. The proposed controller is employed in the specialized frequency converter for domestic water supply systems.

Index Terms—Fluid pressure control, pump speed, controller, feedback control.

I. INTRODUCTION

There are several methods to control the water pressure in water supply systems without using gravity tanks as stop/start control, control using water flow control valve, control by varying pump drive speed etc. The most efficient pressure control method is control by pump speed regulation. Application of this method allows us not only to save the power energy but to increase the pump impeller and bearings life and reduce the vibrations of pump as well. The most commonly used type of variable speed drive is an AC induction motor drive supplied by the frequency converter. The preset water pressure, independent on water consumptions, is kept by the control of the motor and, as a consequence, water pump speed in the feedback control system using frequency converter.

The market of the advanced water supply systems based on the pumps with the AC induction motor drives controlled by the frequency converter increases rapidly nowadays. During the last years the prices of low power frequency converters have dropped significantly. Therefore, the frequency converters-based AC induction motor pump drives become popular in the domestic water supply systems.

Usually, the frequency converter not only generates the variable frequency variable amplitude AC voltage for the motor supply but provides the feedback control of speed using embedded controller as well.

II. PROBLEM FORMULATION

The purpose of the work, to which this paper is dedicated, is development of controller for domestic water supply system designed for the individual house or few individual houses. The purpose of the control system is keeping the constant pressure of water in the accumulator vessel, which is the part of system, independently of water consumption. The control of water pressure is performed by control of pump speed. Typically the three phase AC induction motor drive is used in the pump. The speed of the motor and, as a consequence, the speed of water pump is controlled using frequency converter, which supplies the motor by variable frequency variable amplitude three phase AC voltage. The controller is the part of the frequency converter.

The domestic water supply system has following peculiarities:

- 1) The required head is relatively high because the water to the water supply system is delivered directly from the individual water well;
- 2) The water is consumed with pauses.

The required water pressure is achieved at relatively high speed of pump because of high head. Therefore, the water is not delivered to accumulator vessel at low speed of pump. Because of this, in the control systems based on the commonly used PI and PID controllers [1], the situations when pump drive motor rotates and consumes the power energy without delivering of water, are often met. This problem can be solved by using in the water control system beside the water pressure sensor the water flow sensor. However, this makes the domestic water supply control system more complex and expensive. Because of this, it is topical to develop the controller, which would allow us to solve this problem without using of water flow sensor.

III. MODEL OF WATER SUPPLY SYSTEM

Domestic water supply system typically consists of water well with installed submersible pump and accumulator vessel. The speed of pump drive AC induction motor and, consequently, the water pressure in the water supply system is controlled by the variation of frequency of voltage provided by the frequency converter.

The proposed domestic water supply system model in form of block diagram created using the dynamic system

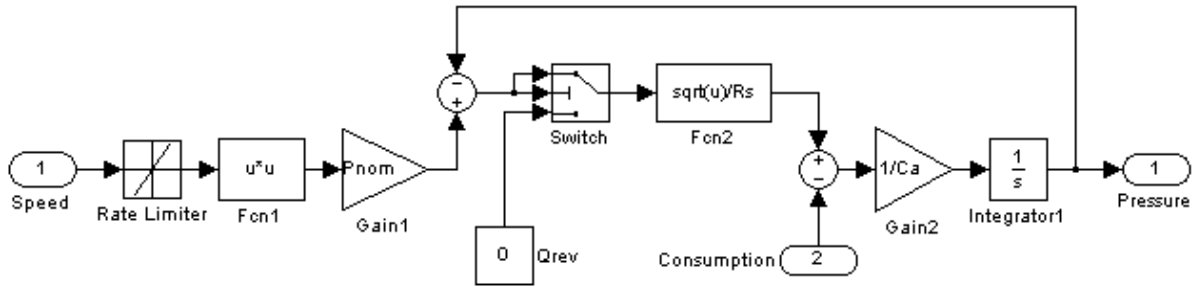

Fig. 1. Simulink model of water supply system.

simulation program Simulink is presented in Fig. 1. The blocks *Fcn1*, *Gain1* and *Fcn2* present the pump with the motor drive supplied by the frequency converter. The *Rate Limiter* block presents the frequency converter.

The signal for the pump speed control, which changes continuously in the range from 0 to 1, is provided to the port *Speed*.

The block *Fcn1* sets the water pressure P_s dependence on the pump speed N

$$P_s = P_{nom} \left(N / N_{nom} \right)^2, \quad (1)$$

where P_{nom} and N_{nom} are rated values of pressure and speed.

The block *Gain1* sets the head that is developed by pump at rated speed and zero water flow. The block *Fcn2* relates the dependence of water flow Q_s in the pump with the water pressure drop ΔP

$$Q_s = \sqrt{\Delta P} / R_s, \quad (2)$$

where R_s is the pump resistance, which is determined using the HQ (dependence of Head versus Flow rate) characteristics of the pump that are provided by the pump manufacturer. The block *Switch* interlocks the water flow through the pump in case of backward water pressure.

The following linear model of accumulator vessel is used in the proposed model of domestic water supply system

$$P_a = \int Q_a dt / C_a, \quad (3)$$

where P_a is water pressure, Q_a is water flow in the accumulator vessel and C_a is the accumulator vessel capacitance. The value of parameter C_a can be taken from the data provided by the manufacturer or determined using equation $C_a = \Delta V / \Delta P$, where ΔV and ΔP are the changes of water volume and pressure.

The signal that corresponds to water flow in the water supply system is provided to the model using port *Consumption* (Fig. 1). The output signal which is related to water pressure in the accumulator vessel is taken from port *Pressure* (Fig. 1).

The simulation results of pump HQ characteristics (water head dependence on flow rate, which is the main water pump characteristic) of domestic water supply system using developed water supply model (Fig. 1) based on (1)–(3) are

given in Fig. 2. They are obtained for the situation when the Pedrollo 4SR6/9 pump is used. The rated speed of pump (at motor supply voltage frequency $f = 50$ Hz) $N_{nom} = 2900$ rpm, the power of pump drive motor 1,1 kW. The simulation results are compared to experimental one.

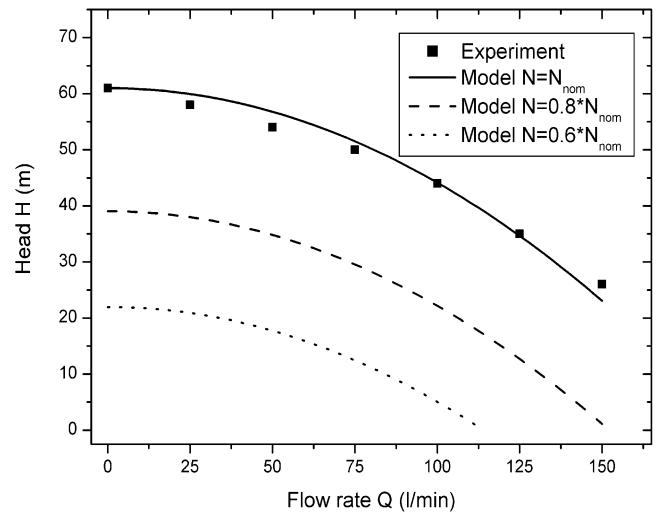

Fig. 2. HQ characteristics of pump at various pump speed.

It is seen that the simulation error of HQ characteristics is 5 % – 10 %. The law of simulated HQ characteristics dependence on pump speed agrees to theory as well [2], it allows us to save the energy consumed by the pump drive and increase the life of pump and motor.

IV. THE CONTROLLER OF WATER SUPPLY SYSTEM

The block diagram of developed controller for the domestic water supply system is presented in Fig. 3. The core of the controller presents PI controller with the anti-windup feature [3]–[6]. It consists of *Gain1*, *Gain2* and *Discrete Time Integrator* with the output signal limitation for the realization of anti-windup property. The peculiarity of the proposed controller in comparison to classical PI controller scheme is that discrete positive and negative shift of set point is introduced in the input of PI controller. The sign of set point shift is determined by the error sign. It is positive at positive errors and negative at negative ones. The set point shift is implemented by blocks *Constant1* and *Switch1*. The introduction of set point shift allows us to avoid in the water supply control system the situation when pump drive motor is rotating without delivering of water, i.e.

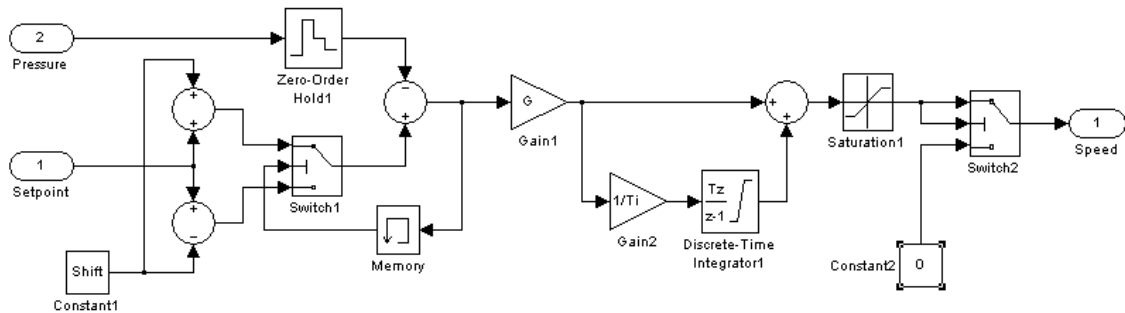

Fig. 3. Simulink model of controller for the domestic water supply system.

The block *Memory* observes the error sign and controls the *Switch1*. It responds not to the recent but to the former error sign. This allows us avoiding instability of water supply control system.

The blocks *Constant2* and *Switch2* stop the motor if according to the controller signal the speed of the motor is lower than the given minimal value. The minimal allowable speed for the most water pumps is 60 % of nominal speed, i.e. the frequency of voltage provided by the frequency converter should be not lower than 30 Hz.

The purpose of the domestic water supply control system is to keep the water pressure in the water supply system as close as possible to the set point value independent on water consumption.

The analyzed domestic water supply control system consists of 20 m deep well, PEDROLLO 4SR6/9 water pump with the AC induction motor drive supplied by the frequency converter and 40 liters accumulator vessel. The analysis was performed using dynamic systems simulation program Simulink. The control system response to water pressure set point step and load disturbance (change of water flow rate) was investigated. The results are presented in Fig. 4.

The water pressure set point value was 2 bars, the load disturbance, which is characterized by the 15 liters/second water flow rate, starts at the 1st minute and ends at 2nd one. It was analyzed the situation when pump starts to deliver the water and in the beginning water is only used to fill the accumulator vessel, i.e. the water is not consumed. Because of this, the water flow peak in the flow transient (Fig. 4(a)) is observed. Since some period water is not consumed, after the accumulator vessel is filled, the controller stops the pump (makes the frequency of voltage delivered to pump drive motor equal to zero) (Fig. 4) to keep the actual water pressure close to set point value. The pump again starts when water consumption begins, i.e. the control system load disturbance is introduced. The obtained transients show how the water pressure in the water supply system with the high system head is sensitive to pump speed change [7], [8]. The pump does not create required pressure until pump speed does not reach the 80 % of nominal speed, which corresponds to 40.1 Hz of frequency of pump drive AC induction motor supply voltage generated by the frequency converter. Till the moment when pump speed reaches this value, the water flow rate is zero, i.e. the water is not delivered from well. It is seen that the water flow transients in the system without the set point shift (dashed line) and

with *Shift* = 0.02 is practically the same. However, after the load disturbance is over and water is not consumed, the transients of pump speed (pump drive motor speed) become strongly different. The motor is stopped quickly if the proposed controller is used (solid line in Fig. 4(b)), and it operates 2.8 minutes if the classical PI controller without set point shift is employed (dashed line in Fig. 4(b)).

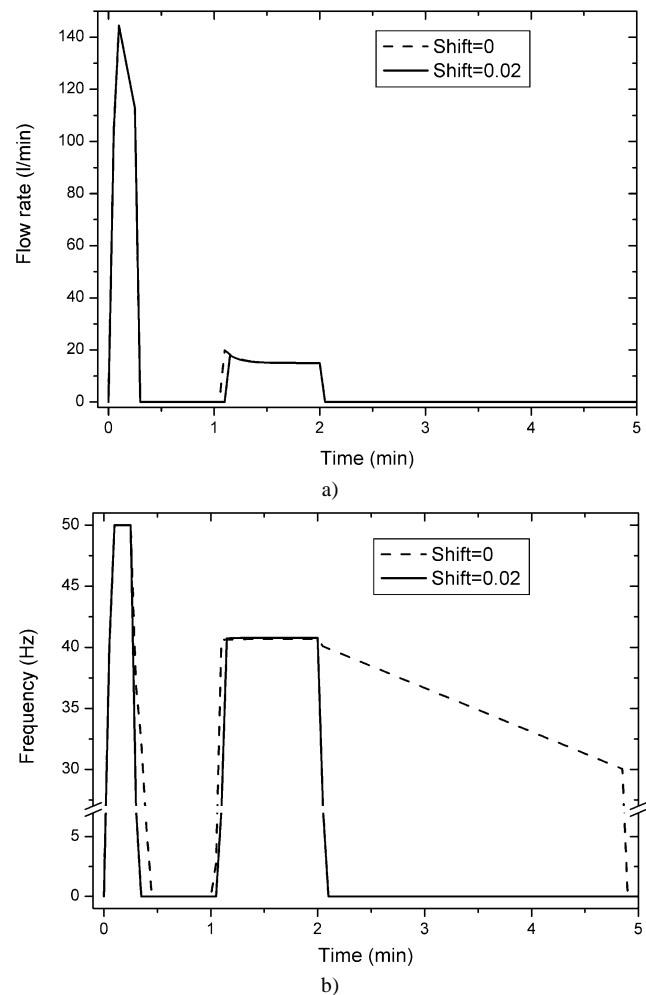

Fig. 4. The flow rate (a) and motor supply voltage frequency (pump speed) (b) response to pressure set point step followed by the water flow rate disturbance when classical PI (*Shift* = 0) and proposed controller (*Shift* = 0.02) are used.

The transients given in Fig. 5 clarify the impact of water pressure set point shift on control system features. If the set point shift is not introduced, i.e. the classical PI controller is used, the value of steady-state error is zero (Fig. 5(a)). The

modulus of steady-state error always is equal to value of set point shift in the system with the set point shift feature (Fig. 5(b)). However, the allowable water pressure errors in the domestic water supply systems usually are higher than errors caused by the introduction of set point shift.

of set point shift in the system with the set point shift feature. However, the allowable water pressure errors in the domestic water supply systems usually are higher than errors caused by the introduction of set point shift.

REFERENCES

- [1] V. Zlosnikas, A. Baskys, V. Gobis, "Investigation of Asymmetric PI Controller using Hardware-in-the-loop Simulation System", *Electronics and Electrical Engineering (Elektronika ir Elektrotechnika)*, no. 7, pp. 7–10, 2009.
- [2] J. A. Fox, *Hydraulic Analysis of Unsteady Flow in Pipe Networks*. London, UK: The MacMillan Press Ltd., 1977.
- [3] H. Shin, J. Park, "Anti-Windup PID controller with integral state predictor for variable-speed motor drives", *IEEE Trans. Industrial Electronics*, vol. 59, no. 3, pp. 1509–1516, 2012. [Online]. Available: <http://dx.doi.org/10.1109/TIE.2011.2163911>
- [4] J. Sofrony, M. Turner, I. Postlethwaite, "A simple anti-windup compensation scheme for systems with rate-limiter actuators", in *Proc. Conf. ICCAS-SICE*, 2009, pp. 3311–3316.
- [5] S. Takamatsu, U. Wasiwitono, M. Saeki, N. Wada, "Anti-windup compensator design considering behavior of controller state", in *Proc. IEEE Conf. Control Applications*, 2010, pp. 1963–1968.
- [6] S. Tavakoli, I. Griffin, P. J. Fleming, "Robust PI controller for load disturbance rejection and set point regulation", in *Proc. IEEE Conf. Control Applications*, 2005, pp. 1015–1020.
- [7] G. Hovstadius, V. Tutterow, S. Bolles, "Getting it Right, Applying a Systems Approach to Variable Speed Pumping", in *Proc. 4th Int. Conf. Energy Efficiency in Motor Driven Systems (EEMODS 05)*, Heidelberg, Germany, Sept. 2005.
- [8] *Variable Speed Pumping – A Guide to Successful Applications*, Europump and Hydraulic Institute, Oxford, UK: Elsevier, Kidlington, 2004.

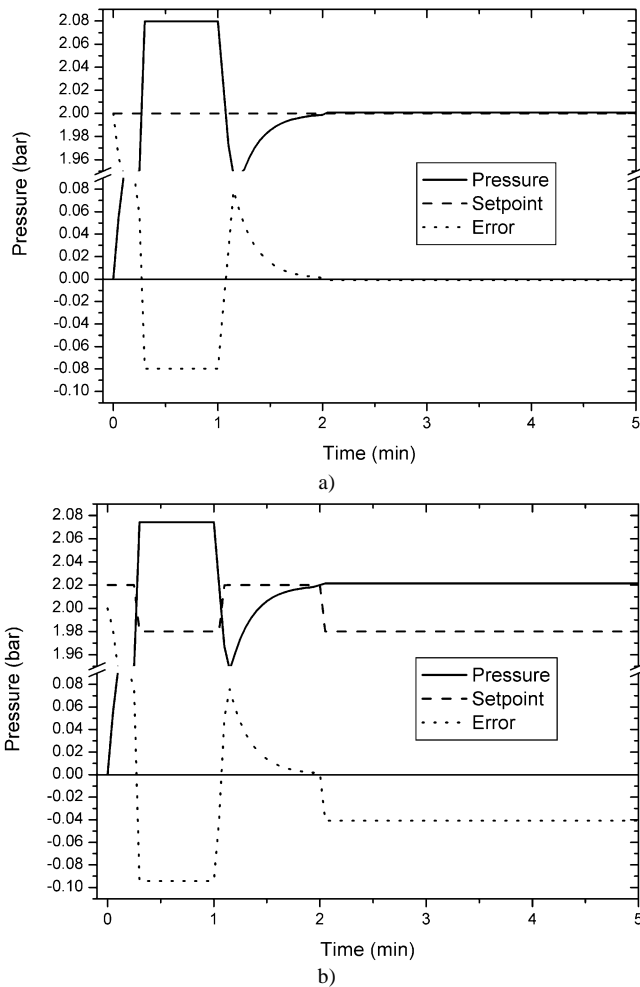

Fig. 5. The water pressure and error response to set point step followed by the water flow rate disturbance for situation when classical PI, $Shift = 0$ (a) and proposed controller, $Shift = 0.02$ (b) are used.

The proposed controller is employed in the specialized frequency converter for domestic water supply systems developed in the Electronic Systems Laboratory of Center for Physical Sciences and Technology for serial production.

V. CONCLUSIONS

The simulation error of water pump HQ characteristics using created domestic water supply system model is 5 % – 10 %. The law of simulated HQ characteristics dependence on pump speed agrees to theory as well.

The peculiarity of the proposed controller of domestic water supply system is that discrete positive and negative shift of set point is introduced in the input of controller.

The set point shift introduction allows us to avoid in the water supply control system the situation when pump drive motor is rotating without delivering of water, i.e. it allows us to save the energy consumed by the pump drive and increase the life of pump and motor as compared to the situation when classical PI controller is used.

The modulus of steady-state error always is equal to value