

Modelling of Ambient Comfort Affect Reward Based Adaptive Laboratory Climate Controller

A. A. Bielskis¹, E. Guseinoviene¹, D. Drungilas^{2,3}, G. Gričius^{2,3}, E. Zulkas³

¹Department of Electrical Engineering, Klaipeda University,
Bijunu St. 17, LT-91225 Klaipeda, Lithuania

²Department of Informatics Engineering, Klaipeda University,
Bijunu St. 17-206, LT- 91225 Klaipeda, Lithuania

³Institute of Mathematics and Informatics, Vilnius University,
Akademijos St. 4, LT-08663 Vilnius, Lithuania
bielskis@ik.ku.lt

Abstract—There are enlarged capabilities of the Ambient Comfort Affect Reward Based Laboratory Climate Controller (ACAR-Controller) by developing and integrating of the Heating/Ventilation/Air Conditioning (HVAC) and the Red-Green-Blue-Yellow (RGBY) Light Emitting Diode (LED) lighting sub-models of one room laboratory in the ACAR-Controller model. The model was validated by implementation and testing of the following elements of the laboratory prototype of ACAR-Controller: a) the sustainable electric power distribution subsystem; b) the intelligent RGBY LED lighting subsystem; c) the non-invasive measuring subsystem of human reaction to comfort conditions in the laboratory; d) the ATMEGA128RFA1-ZU transceivers based wireless communication subsystem; e) the software for the ACAR-Controller.

Index Terms—Thermal comfort, reinforcement learning, radial basis neural network.

I. INTRODUCTION

The variable air volume (VAV) type of heating, ventilating, and/or air-conditioning (HVAC) systems help to creating of users thermal and lighting comfort [1]–[3] in the sustainable home. LED lighting can also increase comfort and save energy in the sustainable home. There is more evidence that blue light (400 – 500 nm) can damage our eyes, with people who have had cataracts removed being particularly vulnerable [2], [4]. In this paper, the HVAC and RGBY LED lighting sub-models and elements of prototype of one room sustainable laboratory are developed to enlarging capabilities of the Ambient Comfort Affect Reward Based Laboratory Climate Controller (ACAR-Controller) proposed in [5].

II. ENLARGEMENT OF THE ACAR-CONTROLLER MODEL

The enlargement of the ACAR-Controller model of Fig. 1 is based on modification of the Ambient Comfort Affect Reward, the ACAR index function [5], as follows

$$ACAR = f\{a(l_{ci}, t_a, a_{ci}, t_b, c, d), v(l_{ci}, t_a, a_{ci}, t_b, c, d)\} = [-3, 3], \quad (1)$$

where a and v are arousal and valence functions respectively dependent on the following ambient comfort and human physiological parameters: l_{ci} – the RGBY LED lighting index defined by the lighting sub-model of a single room laboratory, $T_z = t_a$ – ambient temperature of the zone, and $Wz = a_{ci}$ – air conditioning index of specific humidity in the zone defined by the HVAC sub-model of the single room laboratory, t_b – human body temperature, c – ECG, electrocardiogram and d – EDA, electro-dermal activity. We use fuzzy logic to approximate (1) by defining two fuzzy inference systems: the *Arousal-Valence System*, and the *Ambient Comfort Affect Reward (ACAR) System*. The Radial Basis Neural Network is the main component of the model responsible for two roles - the policy structure, known as the *Actor*, used to select actions, and the estimated value function, known as the *Critic* that criticizes the actions made by the *Actor*.

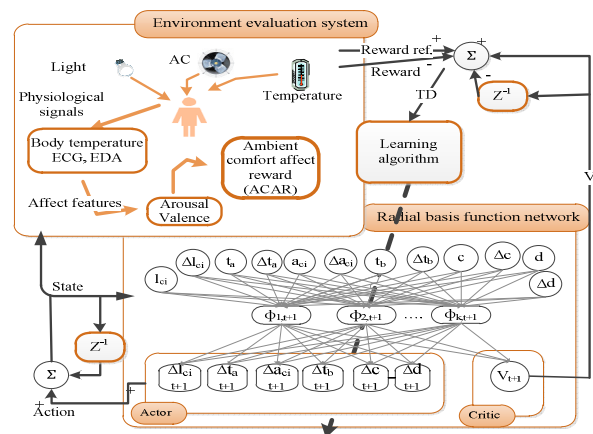

Fig. 1. Block diagram of the model of the ACAR-Controller.

Using reinforcement learning for control with continuous state and action space, a function approximation must be used [6], [7]. A feature state consists of N features, each having an activation factor in the interval $[0, 1]$. Linear approximation calculate their function value with:

$$f(x) = \sum_{i=1}^N \varphi_i(x) \cdot w_i, \quad (2)$$

$$\varphi_s(i) = \exp\left(-\frac{\|s - c_i\|^2}{2\sigma_i^2}\right), \quad (3)$$

$$\delta_{TD}(t) = r(t) + \gamma V(t+1) - V(t), \quad (4)$$

where $\varphi(x)$ is the activation function and w_i is the weight of the feature i , $\phi_s(i)$ is dependent only on the distance between the state, s , the center state of the feature, c_i and it is relative to the feature's width, σ_i , $r(t)$ is the external reinforcement reward signal, $0 < \gamma < 1$ denotes the discount factor that is used to determine the proportion of the delay to the future rewards. The TD error indicates the goodness of the actual action [7], and the weight vector θ of the policy function and the value function are updated as:

$$\bar{\theta}_{t+1} = \bar{\theta}_t + \alpha \delta_t \bar{e}_t, \quad (5)$$

$$\begin{cases} \bar{e}_0 = 0, \\ \bar{e}_{t+1} = \gamma \lambda e_{t-1} + \nabla_{\bar{\theta}_t} V(t). \end{cases} \quad (6)$$

The Model of ACAR-Controller consists of the following parts: the *Environment Evaluation System*, the *Radial Basis Neural Network*, and the *Learning Algorithm*. The *Environment Evaluation System* is used to evaluate the ambient human comfort by sensing the influence of the following environment parameters: the *Temperature*, the *Lighting*, and the *Air Conditioning*.

III. HVAC SUB-MODEL OF A SINGLE ROOM LABORATORY

The model of [8] was used for representing a single zone HVAC system with a single heater and humidifier described by the following state-space equation

$$\dot{x} = Ax + Bu, y = Cx, \quad (7)$$

where the state variable matrix $x^T = [T_{he} \ W_{he} \ T_{hu} \ W_{hu} \ T_{out} \ T_{w1} \ T_{w2} \ T_r \ T_z \ W_z]$; input variable matrix $Bu^T = [b_1u_1 \ b_2u_2 \ b_3u_3 \ b_4u_4 \ b_5u_5 \ b_6u_6 \ b_7u_7 \ b_8u_8 \ b_9u_9 \ b_{10}u_{10}]$; output variables $T_z = [0 \ 0 \ 0 \ 0 \ 0 \ 0 \ 0 \ 0 \ 1 \ 0]^*x$ and $W_z = [0 \ 0 \ 0 \ 0 \ 0 \ 0 \ 0 \ 0 \ 0 \ 1]^*x$; the 10×10 coefficient matrix $A = [a_{11} \ \dots \ a_{110} \ a_{21} \ \dots \ a_{210} \ a_{31} \ \dots \ a_{310} \ a_{41} \ \dots \ a_{410} \ a_{51} \ \dots \ a_{510} \ a_{61} \ \dots \ a_{610} \ a_{71} \ \dots \ a_{710} \ a_{81} \ \dots \ a_{810} \ a_{91} \ \dots \ a_{910} \ a_{101} \ \dots \ a_{1010}]$; $a_{11} = (-f_{sa}\rho_a C_{pa} / (C_{ah}) - ((UA_a) / (C_{ah})))$; $b_1u_1 = ((UA_a) / (C_{ah})) T_0 + f_{sa}\rho_a C_{pa} / (C_{ah}) (T_m) + (s_{sw}\rho_w C_{pw} / (C_{ah})) (T_{wi} - T_{wo})$; $a_{22} = (-f_{sa} / (W_{ah}))$; $b_2u_2 = (f_{sa} / (W_{ah})) (W_m)$; $a_{31} = ((f_{sa}\rho_a C_{pa}) / (C_h))$; $a_{33} = (-((f_{sa}\rho_a C_{pa}) / (C_h)) - ((\alpha_h) / (C_h)))$; $b_3u_3 = ((\alpha_h) / (C_h)) T_0$; $a_{42} = (f_{sa} / (V_h))$; $b_4u_4 = h(\tau) / (V_h \rho_a)$; $a_{53} = ((h_i + h_o) m_a C_{pa} / (h_i M_c C_c))$; $a_{55} = -(h_i + h_o) m_a C_{pa} / (h_i M_c C_c)$; $a_{66} = (-2(U_{w1} A_{w1}) / (C_{w1}))$; $a_{69} = ((U_{w1} A_{w1}) / (C_{w1}))$; $b_6u_6 = ((U_{w1} A_{w1}) / (C_{w1})) T_0$; $a_{77} = (-2(U_{w2} A_{w2}) / (C_{w2}))$; $a_{79} = ((U_{w2} A_{w2}) / (C_{w2}))$; $b_7u_7 = ((U_{w2} A_{w2}) / (C_{w2})) T_0$; $a_{88} = (-2(U_r A_r) / (C_r))$; $a_{89} = ((U_r A_r) / (C_r))$; $b_8u_8 = ((U_r A_r) / (C_r)) T_0$; $a_{95} = (s_{sa}\rho_a C_{pa}) / (C_z)$; $a_{96} = (2U_{w1} A_{w1}) / (C_z)$; $a_{97} = (2U_{w2} A_{w2}) / (C_z)$; $a_{98} = (U_r A_r) / (C_z)$; $a_{99} = (-s_{sa}\rho_a C_{pa}) / (C_z) - (2U_{w1} A_{w1}) / (C_z) - (2U_{w2} A_{w2}) / (C_z) - (U_r A_r) / (C_z)$; $a_{104} = (-f_{sa} / (V_z))$; $a_{1010} = (f_{sa} / (V_z))$; $b_{10}u_{10} = \rho(\tau) / (V_z \rho_a)$; $T_m = (m_r T_r + m_o T_o) / (m_r + m_o)$; $W_m = (m_r W_r + m_o W_o) / (m_r + m_o)$; $a_{12} = a_{13} = \dots = a_{109} = 0$.

Nomenclature given in [8] for the equations above are as follows: T_{he} – temperature of air when it leaves the heater

($^{\circ}C$); T_{hu} – temperature of air when it leaves the humidifier($^{\circ}C$); T_{out} – temperature of air when it leaves the duct($^{\circ}C$); T_{w1} – temperature of wall 1 and 3($^{\circ}C$); T_{w2} – temperature of the wall 2 and 4 ($^{\circ}C$); T_r – temperature of the roof ($^{\circ}C$); T_z – temperature of the zone($^{\circ}C$); T_o – outside air temperature ($^{\circ}C$); T_m – temperature of mixed air ($^{\circ}C$); W_{he} – specific humidity of air when it leaves the heater (kg/kg); W_{hu} – specific humidity of air when it leaves humidifier (kg/kg); W_z – specific humidity of the zone(kg/kg); W_o – specific humidity of outside air (kg/kg); W_m – specific humidity of the mixed air (kg/kg); C_{ah} – thermal capacity of the air handling unit (kJ/C); C_h – thermal capacity of the humidifier (kJ/C); C_{w1} – thermal capacity of the wall 1 and 3 (kJ/C); C_{w2} – thermal capacity of wall 2 and 4 (kJ/C); C_r – thermal capacity of roof (kJ/C); C_z – thermal capacity of the zone (kJ/C); C_{pw} – specific heat of water (kJ/kg); – specific heat of air (kJ/kg); V_{ah} – volume of air handling unit; V_h – volume of humidifier; V_z – volume of the zone; f_{sw} – flow rate of hot water (m^3/s); f_{sa} – flow rate of air (m^3/s); UA_a – overall transmittance area factor of the humidifier (kJ/sC); a_h – overall transmittance area factor of the air handling unit (kJ/sC); ρ_a – density of the air (kg/m^3); ρ_w – density of water (kg/m^3); $h(t)$ – rate of moisture air produced in the humidifier (kg/m^2); h_i – heat transfer coefficient inside the duct (W/m^2C); h_o – heat transfer coefficient in the ambient (W/m^2C); $m_a = 6.04 \text{ kg/m}$ – mass of the duct (kg/m); U_{w1} , U_{w2} , and U_r – overall heat transfer coefficient of the walls 1 and 3, 2 and 4, and of the roof respectively (W/m^2C); A_{w1} , A_{w2} , and A_r – area of the wall 1 and 3, wall 2 and 4, and of the roof respectively (m^2); To verify the Matlab simulation of the state-space equations (7), the following values of the parameters of the HVAC sub model of one room laboratory were used: $C_{ah} = 4.5$, $C_h = 0.63$; $C_{w1} = 70$; $C_{w2} = 60$; $C_r = 80$; $C_z = 47.1$; $C_{pw} = 4.168$; $C_{pa} = 1.005$; $V_{ah} = 2.88$; $V_z = 36$; $V_z = 36$; $f_{sa} = 0.192$; $UA_a = 0.04$; $\rho_a = 1.2$; $a_h = 0.0183$; $\rho_w = 998$; $h_i = 8.33$; $h_o = 16.6$; $m_a = 6.04$; $U_{w1} = 2$; $U_{w2} = 2$; $U_r = 1$; $A_{w1} = 18$; $A_{w2} = 9$; $A_r = 18$.

IV. LIGHTING SUB-MODEL IN A SINGLE ROOM LABORATORY

Modeling the lighting inside the room, the illumination inside the environment can be classified into two categories: artificial lighting and natural illumination. The light radiation is assumed to be uniform while, for light sources the following assumptions are as follows: a) artificial sources are approximated to point light sources; b) natural sources are considered as extended light sources. Given the room/lights and room/window dimensions, the above assumptions can be considered by using the expression (8) proposed in [2]

$$\sum_{j=1}^2 \left[\left[C_{c_j} \cdot E_{(ND_{gl})_j} + C_{r_j} \cdot E_{(NR_{gl})_j} \right] + \frac{\tau_j + V_j \cdot A_{gl_j} \cdot \sigma_{weighted}}{\text{sum}_{AREA} \cdot (1 - \sigma_{weighted})} \cdot E_{NAT_{gl_j}} \right] + \frac{I_L \cdot \text{Lumen}}{1000 \cdot \cos(\gamma)^3} + \frac{\text{Lumen} \cdot \eta \cdot M \cdot P}{\text{Sum}_{AREA} \cdot (1 - \sigma_{weighted})}, \quad (8)$$

where $E_d(P)$ – environment illumination at the point of

interest $P(x,y,z)$ (Lux), $E(ND_{gl})_j$ – natural diffuse illumination on windows (Lux), $E(NR_{gl})_j$ – natural reflection illumination on glass (Lux), $E(NAT_{gl})_j$ – natural direct illumination on glass (Lux), C_{mc}/C_{mr} – diffuse/reflection illumination at the point of interest $P(x,y,z)$ (Lux), I_L – artificial light source (cd/klm), $Lumen$ – luminous flux (lm), γ – incidence angle of the light radiation in the relation to the point of interest $P(x,y,z)$ ($^\circ$), d – distance between point of interest and light source (m), $\sigma_{weighted}$ – reflection coefficient of the walls, sum_{area} – total area of the reflective walls $A_{w1} = 2*18 + A_{w2} = 2*9 + A_r = 18 = 63 (m^2)$, η – efficiency of the light source, and M – environmental maintenance factor.

V. PRACTICAL IMPLEMENTATION OF ELEMENTS OF ACAR-CONTROLLER FOR THE SINGLE ROOM LABORATORY

Figure 2, Fig. 3 and Fig. 5 represent the following wireless communication elements of prototype of the ACAR-Controller for the single room laboratory: the sustainable electric power distribution subsystem (SEPDS) for measuring, sustainable control and delivering power to electric heater and fans by using triac type AC power controllers (Fig. 2).

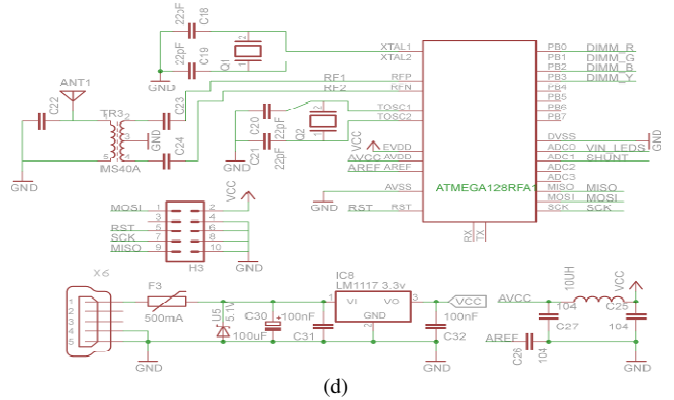
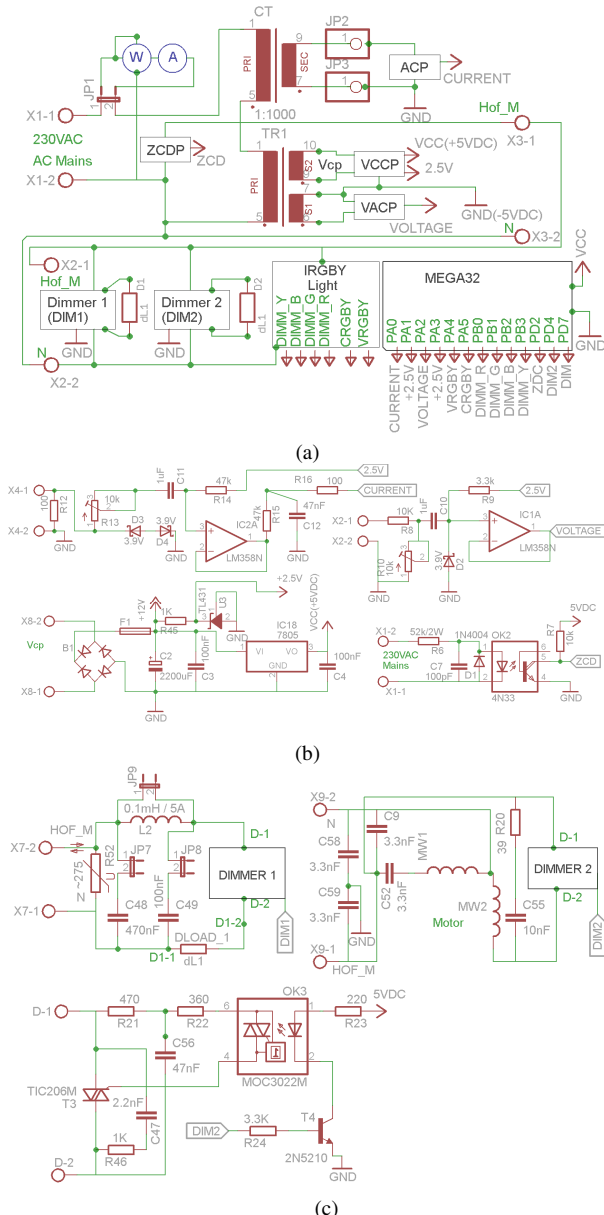

Fig. 2. The sustainable electric power distribution subsystem (SEPDS) for measuring, sustainable control and delivering power to electric heater and fans by using triac type AC power controllers: a) block diagram; b) and c) sub modules; d) Mega128RFA1 transceiver board.

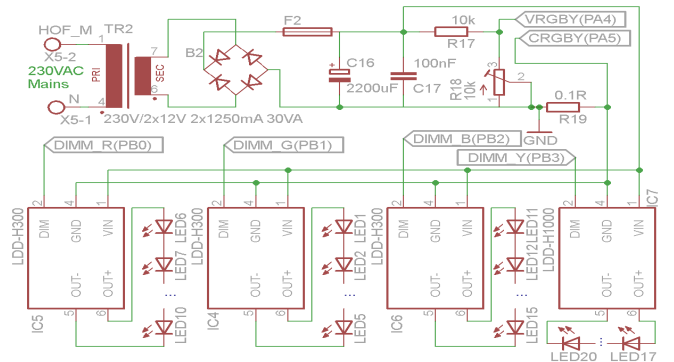

Fig. 3. IRGBY Light - the intelligent RGBY lighting subsystem with dimmable current stabilizers for each RGBY power LED.

The intelligent RGBY lighting subsystem with dimmable current stabilizers for each RGBY power LED (Fig. 3).

```

msr_info.v_rms_sum += (int32_t)msr_info.raw_inst_voltage * msr_info.raw_inst_voltage;
msr_info.i_rms_sum += (uint32_t)msr_info.raw_inst_current * msr_info.raw_inst_current;
msr_info.vi_sum += (int32_t)msr_info.raw_inst_voltage*msr_info.raw_inst_current;
double v_rms = sqrt((double)msr_info.v_rms_sum / NUM_SAMPLES * v_coef);
double i_rms = sqrt((double)msr_info.i_rms_sum / NUM_SAMPLES * i_coef);
double p = (int32_t)msr_info.vi_sum / NUM_SAMPLES * (i_coef/gain) * v_coef;
    
```

Fig. 4. C program block for implementation of measurement of current and voltage characteristics on Mega32-P.

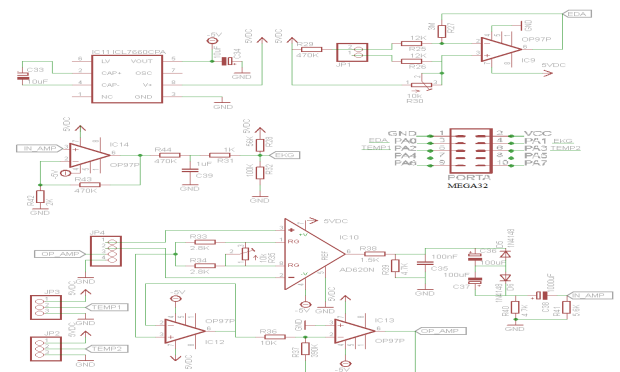

Fig. 5. HRMS - the non-invasive measuring subsystem of human reaction to comfort conditions in the laboratory.

The noninvasive measuring subsystem of human reaction

to comfort conditions in the laboratory (Fig. 5); the ATMEGA128RFA1-ZU transceivers based wireless communication subsystem which uses the 802.15.4 ZigBee low-power, short-distance wireless ISM standard for the 2.4GHz license-free radio bands (Fig. 2(c)).

VI. EXPERIMENTAL RESULTS AND DISCUSSION

Figure 6 depicts digital measurement results of output signals of *VOLTAGE* (VACP block of Fig. 2(a)) and *CURRENT* (ACP block of Fig. 2(a)) measured by Mega32-P board of Fig. 2(b) respectively: for voltage a) and current b) of 0,7 Kw heater, for voltage c) and current d) of the computer monitor, and for voltage e) and current f) of an refrigerator.

The calculations of RMS values of current, $I_{RMS} = \sqrt{\sum(v_i C_i / G)^2 / n} = 2825.6$ mA, voltage, $V_{RMS} = \sqrt{\sum(v_i C_v)^2 / n} = 230.0$ V, apparent power, $S_{apparent} = V_{RMS} * I_{RMS} = 649.9$ VA, real power, $P = \sum(v_i C_i v_i C_v / n G) = 628.119$ W, power factor, $PF = P / S_{apparent} = 0.9665$, $C_i = 0.1206$, $C_v = 0.75$, $G = 1110/200$, and $n = 3000$ for the 0,7 kW heater are performed by system software every 0.7 sec as shown in Fig.4. The constants C_v and C_i were calculated by using values of voltmeter, V (not shown in Fig. 2(a)), ampermeter, A , and watmeter, W , of Fig. 2a. The values of power factor of monitor and refrigerator are as follows: $PF_{monitor} = 0.3437$, and $PF_{refrigerator} = 0.2598$.

Digital measurements of instantaneous values of k sample of the mains voltage $(v_k + v_{k+2})/2$ and current i_{k+1} taken by the load from the mains have been performed every 0.8 ms at 25 samples per 20 ms period or 14.4° . Instantaneous active power value $p_k = ((v_k + v_{k+2})/2) * i_{k+1}$ was calculated after 3 first type differential conversions of every adjacent sample that takes 25 ADC clock cycles at a maximum speed of conversion of 200 KHz each, and $25/200.10^3 = 0.125$ ms or $6.28 * 0.125/20 = 0.03925$ radians/2.25 degrees.

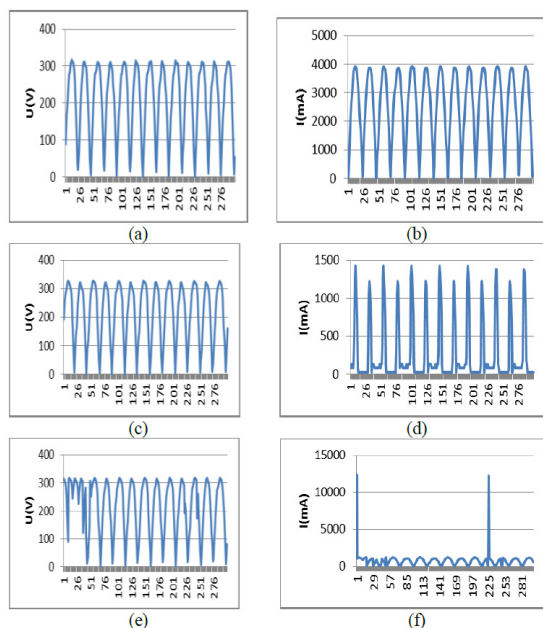

Fig. 6. Instantaneous values of output signals of *VOLTAGE* (VACP block of Fig. 2(a)) and *CURRENT* (ACP block of Fig. 2(a)) measured by Mega32-P board of Fig. 2(b) respectively: for voltage a) and current b) of 0,7 kW heater; for voltage c) and current d) of computer monitor; for voltage e) and current f) of refrigerator.

The sample error can be: between the values of $Err_{max} = 512 * (\sin(0.03925)) = 20,09$ (3.92%) and $Err_{min} = 512 * (\sin(3.14/2) - (3.14/2 - 0.03925)) = 0.461$ (0.09%) which is acceptable.

VII. CONCLUSIONS

The HVAC and RGBY LED lighting sub-models and elements of prototype of one room sustainable laboratory are developed to enlarging capabilities of the Ambient Comfort Affect Reward Based Laboratory Climate Controller (ACAR-Controller).

The validation of the model of ACAR-Controller is performed by implementation and testing of the electric power distribution, RGBY lighting, the ATMEGA128RFA1-ZU transceivers based wireless communication subsystems, and the module of noninvasive measuring of human reaction to comfort conditions in the laboratory.

Digital measurements of instantaneous values of samples of pairs of the mains voltage and current every 0.8 ms as well as calculations of the active, apparent power and the power factor are performed in real time every 0.7 sec by Atmega32 microcontroller for the following electric power consumers: the 0.7 kW heater, the computer monitor, and the refrigerator.

The maximum sample error was less then or equal to 3.92% which is acceptable.

REFERENCES

- [1] G. Zheng, Y. Jing, H. Huang, P. Ma, "Thermal Comfort and Indoor Air Quality of Task Ambient Air Conditioning in Modern Office Buildings", in *Proc. International Conference on Information Management, Innovation Management and Industrial Engineering (ICIII 09)*, 2009, vol. 2, pp. 533–536.
- [2] S. M. Zanoli, D. Barchiesi, "Thermal and Lighting Control System with Energy Saving and Users Comfort Features" in *Proc. 20th Mediterranean Conference on Control & Automation (MED)*, Barcelona, 2012, pp. 1322–1327.
- [3] M. Prek, "Thermodynamical analysis of human thermal comfort" Elsevier, *Energy*, no. 31, pp. 732–743, 2006. [Online]. Available: <http://dx.doi.org/10.1016/j.energy.2005.05.001>
- [4] A. Quarto, V. Di Lecce, R. Dario, J. Uva, "Personal dosimeter for the measurement of artificial optical radiation (AOR) exposure", in *Conf. IEEE International Conference on Computational Intelligence for Measurement Systems and Applications (CIMSIA)*, Ottawa, 2011, pp. 47–52.
- [5] A. A. Bielskis, E. Guseinovi en , D. Dzemydien , D. Drungilas, G. Gri cius, "Ambient Comfort Affect Reward Based Multi-Agent Lighting Controller", *Elektronika ir Elektrotechnika (Electronics and Electrical Engineering)*, vol. 18, no. 5, pp. 79–84, 2012.
- [6] K. Dalamagkidis, D. Kolokotsa, "Reinforcement Learning for Building Environmental Control" *Reinforcement Learning: Theory and Applications, I-Tech Education and Publishing*, 2008, p. 424.
- [7] R. S. Sutton, A. G. Barto, *Reinforcement learning: An Introduction*. MIT Press, Cambridge, MA, 1998, p. 322.
- [8] K. Chinnakani, A. Krishnamurthy, J. Moyne, A. Arbor, F. Gu, "Comparison of Energy Consumption in HVAC Systems Using Simple ON–OFF, Intelligent ON–OFF and Optimal Controllers", in *Proc. IEEE Power and Energy Society General Meeting*, 2011, pp. 1–6. [Online]. Available: <http://dx.doi.org/10.1109/PES.2011.6039823>