

## Fully Controllable First Order Current Mode Universal Filter Composed of BJTs and a Grounded Capacitor

R. Arslanalp, A. T. Tola, E. Yuçe

Department of Electrical and Electronics Engineering, Pamukkale University, Denizli, Kinikli-20070, Turkey, phones: +90 258 2963214, +90 258 2963196, +90 258 2963217, e-mails: rarslanalp@pau.edu.tr, attola@pau.edu.tr, erkanyuce@yahoo.com

**crossref** <http://dx.doi.org/10.5755/j01.eee.112.6.448>

### Introduction

In the last two decades, current-mode (CM) circuits have received more attention. These types of circuits offer many advantages such as wider bandwidth, bigger dynamic range, better linearity and more IC suitability when compared with voltage mode (VM) topologies [1, 2]. In addition to this, electronic tunability is also one of the other important issues in electronic design since it allows us to control characteristics of circuit easily, i.e. resonance frequency of filter [3]. In a tunable circuit, electronically control can be achieved via biasing currents in BJT technology. In the literature, many CM and VM filters have been presented [4-10]. However, some of the reported circuits suffer from shortcoming of electronic tunability [5]. Quite a large number of filters composed of basic building block(s) such as current conveyors were also previously reported whereas each of the blocks use tens of transistors [3-8].

This paper presents an electronically tunable CM first order universal filter employing only a grounded capacitor and fewer BJTs [11] when compared with previously published ones. The proposed filter can produce all the standard filter functions i.e. low-pass, high-pass and all-pass filters. Cut-off frequency can be tunable and filter types can also be controllable by simply changing the values of some current sources. The introduced circuit is free from critical passive component matching conditions and cancellation constraints, and provides high output impedance yielding easy cascading. Moreover, second order band-pass filter obtained by cascading low-pass filter and high-pass filter is also presented as an application. The validity of proposed filter is verified through PSpice simulations.

### Proposed First-Order Universal Filter

A generalized first order transfer function is given in (1). Type of a filter is determined by the coefficients  $a_1$  and  $a_0$ , e.g. low pass, high pass, etc.

$$H(s) = \frac{a_1 s + a_0}{s + \omega_o} \quad (1)$$

Many techniques are available to design a filter from transfer function of system. One of them is known as block diagram technique. It is easy to rearrange system by obeying manipulation rules in accordance with design purposes. Moreover, it is very simple way to construct complicate systems by using functional blocks. Let's multiply with  $(-\frac{Cv}{k_2})$  numerator and denominator of the transfer function

$$H(s) = \frac{i_{out}}{i_{in}} = \frac{-\frac{a_1 s C v}{k_2} - \frac{a_0 C v}{k_2}}{-\frac{s C v}{k_2} - \frac{\omega_o C v}{k_2}} \quad (2)$$

Output current can be defined as given in (3)

$$i_{out} = a_1 i_{in} + \left( \frac{a_1}{k_2} - \frac{a_0}{k_2 \omega_o} \right) i_x \quad (3)$$

where

$$i_x = -k_2 i_{in} - i_{cap} \quad (4)$$

$$i_{cap} = s C v \quad (5)$$

$$v = R i_x \quad (6)$$

In these equations,  $k_2$  is constant term while  $R$  and  $C$  depicts resistance value and capacitance value respectively.

Next step of designing first order filter is mapping on coefficients of generalized first order filter transfer function given in (1) to obtain appropriate system equations to realize function by using BJTs and a grounded capacitor. For this purpose, each coefficient of numerator of transfer function is assigned to a function. It should be noted that by using this way general characteristics of system remains unchanged. Let's assume  $a_0 = (k_1 - k_2)\omega_o$  and  $a_1 = k_1$  yields input current and output current as given in (7) and (8) respectively:

$$k_2 i_{in} = -i_x - i_{cap}, \quad (7)$$

$$i_{out} = k_1 i_{in} + i_x. \quad (8)$$

These system equations can be considered as node equations. Both of two equations have scaling terms multiplied with input current. As mentioned above, these terms consists of numerator's coefficients of transfer function can be controlled by tuning some dc current sources. It means that type of first order filter can be selected electronically.

The expression of  $i_x$  is given clearly in (9). This current which is key aspect of design consist of two constant terms,  $\omega_o$ , cut off frequency,  $C$ , the value of capacitor, and one time varying term,  $v$ , the value of node voltage. Cut off frequency of proposed first order filter is given in (10):

$$i_x = \omega_o C v, \quad (9)$$

$$\omega_o = \frac{I_f}{C V_T}. \quad (10)$$

A block diagram of representation of system is given in Fig. 1. The block diagram consists of functional blocks of generalized first order filter function and summing blocks. There are three types of functional blocks, namely multiplying constant term block used to acquire electronically tunability, current to voltage converter block and differentiator block which is also used for voltage to current converter.

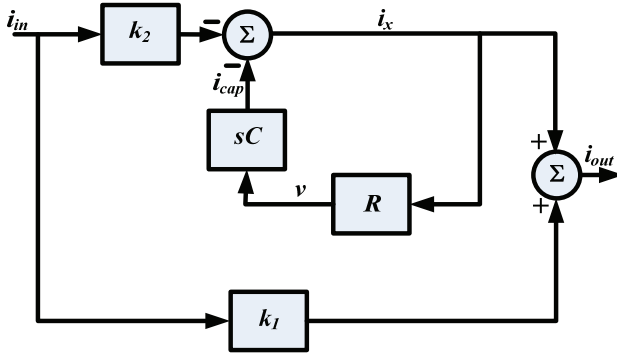


Fig. 1. Block diagram of representation of system

In order to realize constant multiplying block which plays essential role for synthesizing electronically tunable system, static translinear circuit structure are employed [12–14]. By selecting  $k_1$  and  $k_2$  all first order filter types can be produced as given in Table 1. It means that this advantage give us wide area of usage without modification on circuit architecture. It is also offers economic reasons to use of this circuit which have ability of electronically controllability since same manufactured circuit can be used for many purpose.

Table 1. Types of filters and their characteristics via control variables  $k_1, k_2$

$k_1$	$k_2$	Type of filter	Gain	Phase
1	1	high-pass	unity	non-inverting
0	1	low-pass	unity	inverting

1	2	all-pass	unity	non-inverting
---	---	----------	-------	---------------

The proposed first order universal filter employing BJTs, a grounded capacitor and some current sources, shown in Fig. 2, consists of three parts, main circuit, translinear loops, and current mirror. As mentioned above, the proposed filter has capability of to tune cut off frequency and to select filter type. Input current of circuit composed of both input signal and dc bias current depicts pole frequency.  $Q_2$ ,  $Q_3$  and  $Q_5$  transistors are operating in active region and biased as given in Table 2 for all filter responses.

Table 2. Types of filters due to bias currents of BJTs

Type of filter	$Q_2$	$Q_3$	$Q_5$
high-pass	$I_{f1} = I_f$	$I_{f2} = 0.971 I_f$	$I_{f3} = I_f$
low-pass	$I_{f1} = I_f$	$I_{f2} = 0.971 I_f$	OFF
all-pass	$I_{f1} = I_f$	$I_{f2} = 0.4 I_f$	$I_{f3} = I_f$

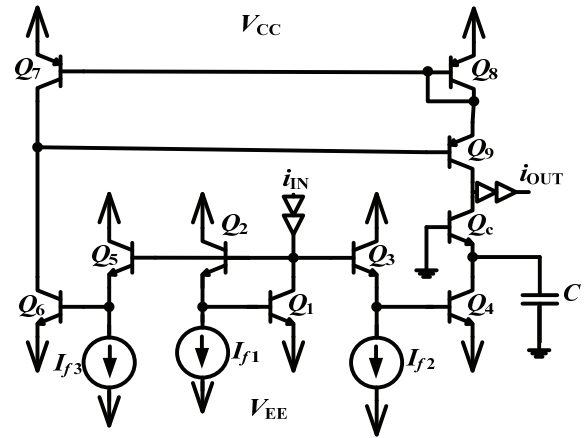


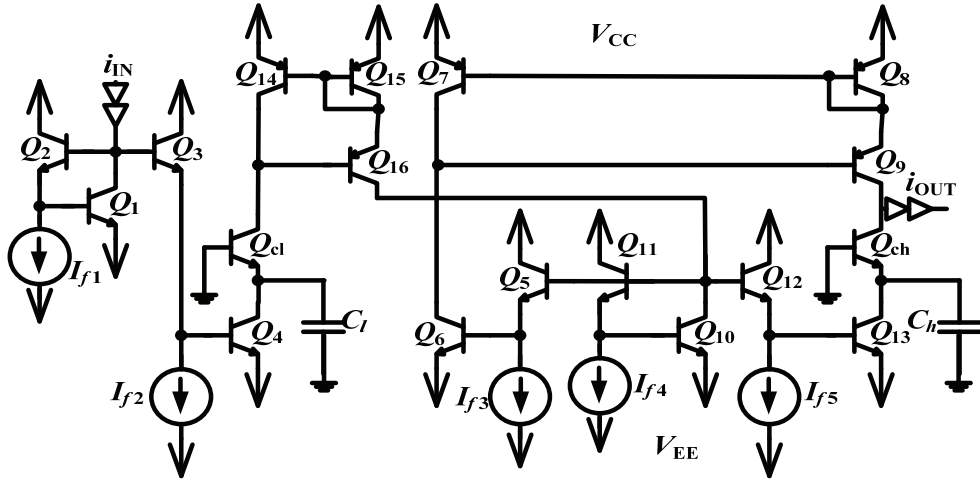
Fig. 2. Proposed first order universal filter

One of the applications of the realized first order universal filter is second order band-pass filter employing only grounded and canonical number of capacitors and BJTs, which is shown in Fig. 3. Essentially, this filter is obtained by cascading first order low-pass filter and first order high-pass filter.

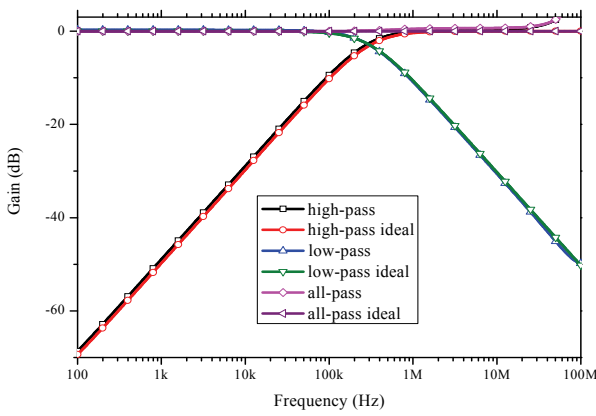
## Simulation Results

In order to confirm the theoretical results detailed previous section, the proposed first order universal filter is simulated in the PSpice program by using both ideal BJT obtained by employing default BJT model with  $BF = 10000$  and CBIC-R model [10]. Obtained simulation results show that theoretical design is verified. The value of capacitance of filter circuit is chosen to be  $C = 10nF$ . The numbers of simulations are performed including time domain analysis and frequency domain analysis. The total power dissipation is found as  $28.4mW$ .

First of all, the frequency responses of all possible filter characteristics are obtained. The gain characteristics of fundamental first order filter responses; high-pass, low-pass and all-pass are given in Fig. 4. As seen from the figure, the simulated and ideal results are in accordance with each other. The values of current sources are set to be as given in Table 2 for each filter.

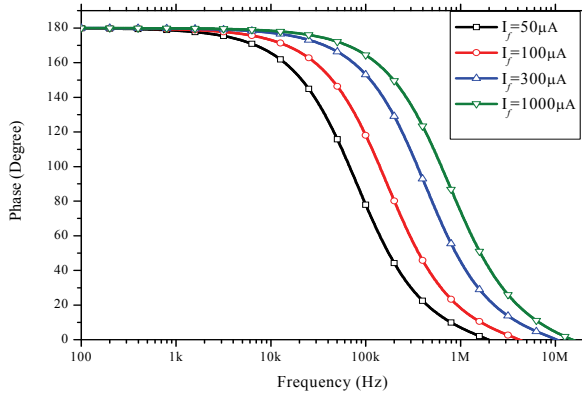


**Fig. 3.** Proposed second order band-pass filter derived from the first order universal filter given in Fig. 2



**Fig. 4.** Gain responses of all first order filters

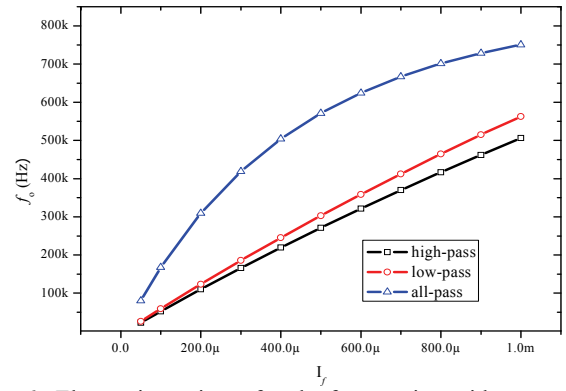
In order to show that electronic tunability capability of the proposed filter, many simulations are performed on cut off frequencies of all filter responses. In Fig. 5 phase responses of all-pass filter for various dc current values are given. Fig. 6 points out cut off variations due to dc current value. Control dc current is tuned from  $I_f = 50\mu A$  to  $I_f = 1mA$  that yields cut off frequency of all-pass filter is swept approximately more than one decade.



**Fig. 5.** Phase responses of all-pass filter for various  $I_f$

Total harmonic distortion (THD) of output signal of the proposed filter circuit is also measured when sinusoidal input signal is applied. Characteristics of input signal and

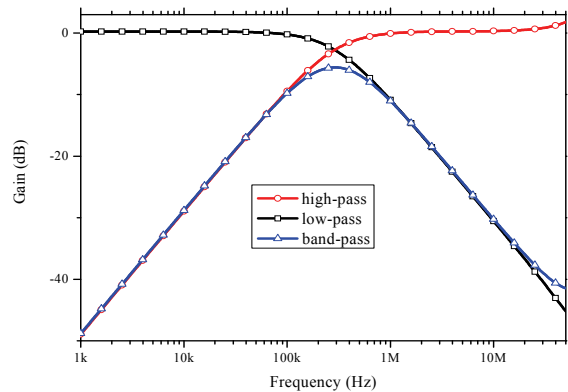
dc operating point defines cut off frequency and measured THD values for all filter responses are depicted in Table 3.



**Fig. 6.** Electronic tuning of pole frequencies with respect to control current  $I_f$

**Table 3.** THD values of all filter responses and information

Characteristic	Value
$I_f$	$500\mu A$
Peak value of input signal	$100\mu A$
Frequency of input signal	$1MHz$
%THD for high-pass response	0.3801355
%THD for low-pass response	1.277466
%THD for all-pass response	1.44952



**Fig. 7.** Gain responses of filter given in Fig. 3

Simulated second-order band-pass filter response is drawn as shown in Fig. 7 in which bias currents of both filter is selected as equal to each other. Gain response of each block, low-pass filter block and high-pass filter block is given in the figure, as well.

## Conclusions

In this work, a current mode first order universal filter circuit is presented by obeying block diagram synthesis method. This circuit has many advantages such as capability of not only electronically tunability but also electronically controllability while it offers low component count structure when compared to published ones. Moreover, these features can be attained simply and correctly by changing the values of dc current sources. Additionally, second order band-pass filter is presented as an application example which is obtained by cascading two first order filters. Theoretical design background is also verified through PSpice simulator program. All obtained results are given and discussed in related section. It should be noted that a significant contribution is made to analog electronic by designing this universal circuit.

## References

1. **Tiliute D. E.** Full-wave current-mode precision rectifiers using unity-gain cells // *Electronics and Electrical Engineering*. – Kaunas: Technologija, 2003. – No. 7(49). – P. 26–29.
2. **Ferri G., Guerrini N. C.** Low-voltage low-power CMOS current conveyors. – Kluwer Academic Publishers, London, 2003.
3. **Maheshwari S.** A new current-mode current-controlled all-pass section // *Journal of Circuits, Systems, and Computers*, 2007. – Vol. 16. – P. 181–189.
4. **Hintea S., Faragó P., Festila L., Söser P.** Reconfigurable filter design for implantable auditory prosthesis // *Electronics and Electrical Engineering*. – Kaunas: Technologija, 2010. – No. 3(99). – P. 7–12.
5. **Chang C. M.** Universal active current filter with single input and three outputs using CCII's // *Electronics Letters*, 1993. – Vol. 29. – P. 1932–1933.
6. **Yuce E.** Design and stability analysis of mixed-mode filters containing only grounded capacitors // *Journal of Circuits, Systems, and Computers*. – 2010. – Vol. 19. – P.1345–1363.
7. **Pandy N., Paul S. K.** All-pass filters based on CCII- and CCCII- // *Int. J. Electron.* – 2004 – 91. – P. 485–489.
8. **Yuce E., Pal K., Minaei S.** A high input impedance voltage-mode all-pass/notch filter using a single variable gain current conveyor // *Journal of Circuits, Systems, and Computers*, 2008. – Vol. 17. – P. 827–834.
9. **Comer D. J.** High-frequency narrow-band active filters // *IEEE Transactions on Circuits and Systems*. – Vol. 33. – P. 838–840.
10. **Arslanalp R., Yuce E.** A BJT technology-based current-mode tunable all-pass filter // *Microelectronics Journal*. – 2009. – Vol. 40. – P. 921–927.
11. **Zeltins M., Slaidins I.** Bipolar junction transistor 1/f noise simulation and parameter extraction technique // *Electronics and Electrical Engineering*. – Kaunas: Technologija, 2005. – No. 4(60). – P. 77–80.
12. **Gilbert B.** Translinear circuits: a proposed classification // *Electronics Letters*. – 1975. – Vol. 11. – P. 14–16.
13. **Tiliute D. E.** On dc errors in translinear frequency multipliers // *Electronics and Electrical Engineering*. – Kaunas: Technologija, 2006. – No. 2 (66). – P. 41–44.
14. **Festila L., Szolga L., Hintea S., Cirlugea M.** A unitary view toward analog weighting/amplifying  $F-F^{-1}$  cells // *Electronics and Electrical Engineering*. – Kaunas: Technologija, 2010. – No. 10(106). – P. 21–26.

Received 2011 02 15

**R. Arslanalp, A. T. Tola, E. Yuce. Fully Controllable First Order Current Mode Universal Filter Composed of BJTs and a Grounded Capacitor // Electronics and Electrical Engineering. – Kaunas: Technologija, 2011. – No. 6(112). – P. 69–72.**

In this paper, a new BJT based configuration for providing first order current mode high-pass, low-pass and all-pass filter responses from the same configuration is suggested. The proposed circuit called as a universal filter possesses some important advantages such as consisting of low component count BJT and a grounded capacitor, having electronic tunability property of its pole frequency and having electronic controllability feature of filter types. The suggested circuit does not suffer from disadvantages of use of the resistors. Moreover, as an application, second order band-pass filter is also obtained by cascading two proposed filter structure. Simulations by means of PSpice program are accomplished to demonstrate the performance and effectiveness of the developed first-order universal filter. Approximately more than 1 decade tunability range is achieved. III. 7, bibl. 14, tabl. 3 (in English; abstracts in English and Lithuanian).

**R. Arslanalp, A. T. Tola, E. Yuce. BJT technologijos ir įžemintų kondensatorių taikymas visiškai kontroliuojamame universaliajame pirmos eilės srovės filtru // Elektronika ir elektrotechnika. – Kaunas: Technologija, 2011. – Nr. 6(112). – P. 69–72.**

Siūloma nauja grandinė, vadinamasis, universalusis filtras, pasižymi mažų elementų skaičiumi ir įžemintais kondensatoriais. Tokioje grandinėje išvengiama neigiamo rezistorių poveikio. Antros eilės filtras gali būti gaunamas pakopomis sujungus du siūlomus pirmos eilės filtras. Našumui ir veiksmingumui įvertinti atliktas modeliavimas programų paketu „PSpice“. II. 7, bibl. 14, lent. 3 (anglų kalba; santraukos anglų ir lietuvių k.).