

Non-Destructive Evaluation of Green Ceramic Body Density by Ultrasonic Technique

M. Kulokas, R. Kazys, L. Mazeika

Ultrasound Institute, Kaunas University of Technology,

Studentu str. 50, LT-51368 Kaunas, Lithuania, phone: +370 37 351162, e-mails: mindaugas.kulokas@gmail.com, rymantas.kazys@ktu.lt, liudas.mazeika@ktu.lt

Introduction

The main quality requirements of manufactured ceramic tiles are established by International Organization for Standardization (ISO) standards for individual types of ceramic tiles [1]. Therefore the quality requirements of each line must correspond to ISO and other standards. The quality and durability of the tile depend directly on raw used materials, design of the production line, tile production process, installation and maintenance of the tiled surface [2].

One of very important parameters is density of a green ceramic tiles and particularly spatial variations of the density. The bulk density of a green ceramic body provides valuable information for tiles quality control in a final product inspection by determining porosity, impurities and cracks of the body [3, 4]. Currently, there are different ceramic products quality assurance methods, which allow evaluation of tile porosity, impurities and defects by analysis of the measured density ρ [5-8].

The bulk density of a green ceramic body may be found by ultrasonic methods exploiting relationship between the density ρ and velocity c of ultrasonic waves. Analysis of the physical properties of the object under investigation may be performed by using longitudinal and/or transverse ultrasonic waves. Velocities of ultrasonic waves depend on elastic properties and density of the object under investigation.

The measurements of elastic properties have received much attention, therefore various techniques have been developed which allow perform static loading tests and dynamic ultrasonic and vibration resonant frequency measurements [4, 5].

The ultrasonic longitudinal wave velocity in an elastic homogeneous medium depends on the tested object density ρ , its Young's modulus E and the Poisson's ratio ν and is given by [6]

$$c_L = \sqrt{\frac{E}{\rho} \cdot \frac{(1-\nu)}{(1+\nu)(1-2\nu)}}. \quad (1)$$

Correspondingly, the velocity of an ultrasonic shear wave in an elastic homogeneous medium is [6]

$$c_T = \sqrt{\frac{E}{2\rho} \cdot \frac{1}{(1+\nu)}}. \quad (2)$$

From equation (1) follows that in order to determine from the measured longitudinal ultrasound wave velocity one material parameter, for example, the density ρ , others two parameters must be known or measured by other methods.

Equations (1) and (2) show that if both longitudinal and shear wave velocities can be measured, then the Young's modulus and the Poisson's ratio may be determined. However, in many quality control applications, such as evaluation of the density of a fired ceramic body from the measured longitudinal ultrasonic wave velocity, it is often assumed that the Poisson's ratio can be treated as being approximately constant, and that the Young's modulus follows a cubic relationship with density [7, 8]. As a result, the ultrasound velocity depends almost linearly on density.

These measurements are based on manual sampling of the flow of tiles by an operator who determines the apparent density of tiles. The use of such methods has enabled to control the production process of ceramic tiles on a discontinuous basis during last 20 years.

However, these measurements are very slow, complicated and they do not permit automatic control during a pressing operation. Further steps were directed to increase of a measurement speed, improvement of measurement repeatability and reduction of the measurement uncertainty. Currently, some manufacturers focus on a non-destructive estimation of the apparent density of green ceramic tiles. Example of such improvement is a measurement system, which is manufactured by Sonotec GmbH Halle and is based on an immersion method [9].

However, these systems measure the apparent density off-line and are more applicable for laboratory

measurements and selective production verification. In order to reduce the number of rejected tiles it is necessary to determine the bulk density of a green ceramic body on-line, since the spoiled green ceramic tiles will be detected before baking process. In this way it would be possible to reduce consumption of raw materials and to improve quality of the final product.

For such purpose the ultrasonic measuring system based on the air coupled ultrasonic approach has been developed [10]. This system has been applied for on-line apparent density measurements of ceramic tiles. However, stability and repeatability of the non-contact ultrasonic system may be affected by the following factors:

- Varying temperature (variation due to the drier);
- Dust;
- Vibrations;
- Humidity content of the tile;
- Superficial roughness of the tile;
- Movement of tiles.

For these reasons it is not feasible to reach the desired repeatability and accuracy using air-coupled ultrasonic technique.

Objective of this investigation was development of ultrasonic technique for evaluation of spatial variations of the green ceramic body density and experimental verification of this technique in laboratory conditions.

For solution of this problem measurements of ultrasonic longitudinal wave velocity were performed at different spatial points of green ceramic tiles by a direct transmission method. The obtained measurement results were analyzed and uncertainty of measurements was estimated.

Measurement approach and preparation of specimens

Evaluation of the measured apparent density ρ can be considered as a measurement of the two-dimensional field $\rho(x, y)$ distributed in space, in our case in one plane, e.g. it is assumed that there no density variations across tiles thickness [11].

Physically measurements can be performed at discrete points x_i, y_j on both tile surfaces, what is equivalent to a spatial sampling of the field. In this case this field can be treated as a discrete apparent density field which is given by

$$\rho(x_i, y_j) = \rho(i \cdot \Delta x, j \cdot \Delta y), \quad (3)$$

where i and j is $0, 1, \dots, N-1$, N is number of measurements positions along x and y axis and $\Delta x, \Delta y$ are spatial sampling intervals along the x and y axes.

From the measurements of the apparent density at the discrete points (x_i, y_j) the field $\rho(x, y)$ is reconstructed and gives the bulk density distribution of a green ceramic body.

The original field $\rho(x, y)$ can be restored by summing the measured discrete spatial field values at each field $\rho(x_i, y_j)$ point multiplied by the interpolation function

$$\rho(x, y) = \sum_{i, j} \rho(x_i, y_j) \cdot \frac{\sin(\omega_x \cdot (x - i \cdot \Delta x)) \sin(\omega_y \cdot (y - j \cdot \Delta y))}{(\omega_x \cdot (x - i \cdot \Delta x)) (\omega_y \cdot (y - j \cdot \Delta y))}, \quad (4)$$

where ω_x and ω_y are the highest spatial frequencies of the spatial frequency spectrum of the field $\rho(x, y)$, which correspond to the field components with shortest periods.

In order this reconstruction would be accurate, the sampling intervals, or in other words, the distances between the measurement points must fulfill the following requirements $\Delta x \leq \pi / \omega_x$ and $\Delta y \leq \pi / \omega_y$. It is necessary

to keep in mind that if the spatial spectrum is not band-limited, then additional measurement errors due to overlap of highest spatial components in the spatial spectrum may occur.

The main problem is that *a priori* information about the apparent density field of green ceramic tiles is not yet available, therefore the spatial frequencies ω_x and ω_y are not known also. Therefore first of all measurements of ultrasound velocity at different points of green ceramic tile were carried out.

For this purpose 32 x 32 cm size green ceramic tiles, manufactured by AB „Dvarčionių keramika“, were selected. The tile was cut into 6x6 cm samples according to the Ultrasound Institute laboratory measuring platform (Fig. 1a). The samples were numbered and their thickness d_m values were measured. Numbering of the samples was used for reconstruction of the spatial distribution of the ceramic tiles density.

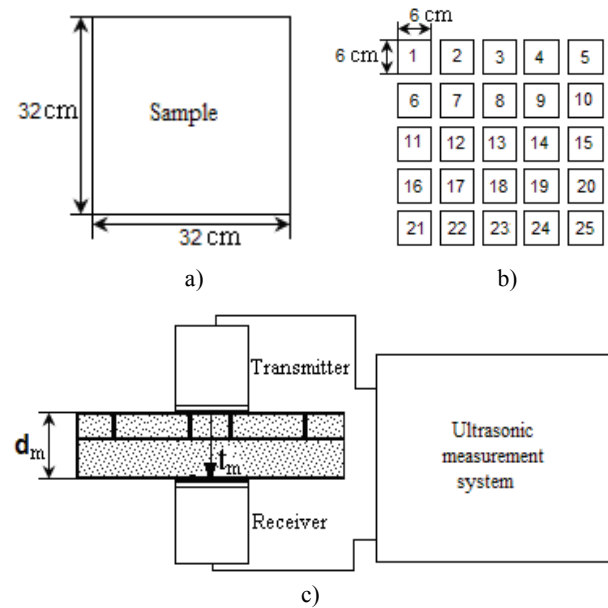

Fig. 1. (a) by AB „Dvarčionių keramika“ made the 32 x 32 cm size green ceramic tile, (b) samples prepared for the density measurements, (c) for the ultrasonic wave propagation speed measurements direct transmission selected method

It is necessary to point out that in the case of a green ceramics, ultrasonic measurements may be performed only using a dry acoustic contact between ultrasonic transducers and the ceramic sample; otherwise the sample will be affected by a liquid, usually used for acoustic coupling. An additional problem is that one side of those specimens is with a rectangle pattern and therefore complicates establishment of a good quality dry acoustic contact. For solution of this problem a dry acoustic contact was realized up by means of a thin (0.73 mm \pm 0.01 mm) vinyl film, which was inserted between the sample and ultrasonic

transducers. The acoustic contact between the film and ultrasonic transducers was obtained by glycerin.

According to results of previous experiments by various ultrasonic transducers for measurements were selected PISL CX-165 5 MHz .25"A and П111-5.0-K6-002 ultrasonic transducers, which were placed along one axis on both sides of the ceramic sample (Fig. 1b).

In order to obtain and ensure a stable acoustic contact for measurements, the ultrasonic transducers were pressed to the sample via a vinyl film by 4 kg weight. This weight was selected during experiments and was kept 2 min. until the measured waveform will be stable during each measurement on the sample, and the longitudinal ultrasonic wave propagation time measurement error was minimal for this film thickness variation.

Measurements methods and results

The objects under investigation are isotropic, therefore velocities of the ultrasonic longitudinal c_L and transverse c_T waves should not depend on a propagation direction. In this case the propagation velocity of longitudinal ultrasonic wave c_L was measured in the center of the samples, when the transducers were placed on one axis from on both surfaces of the sample, using zero-crossing and cross-correlation techniques (Fig. 2).

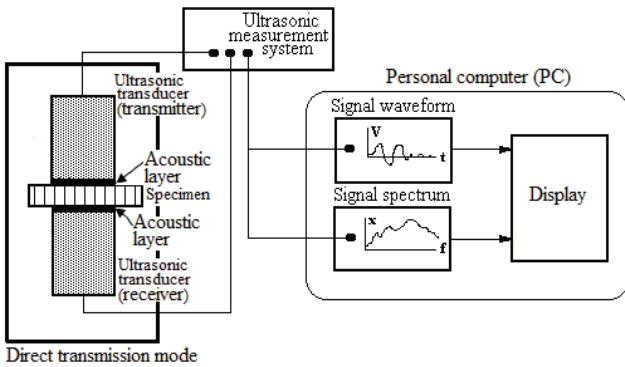

Fig. 2. The ultrasonic direct transmission density measurement technique set-up

The measurement of the longitudinal ultrasonic wave propagation time in green ceramic tile by using the zero-crossing technique was performed as follows. First of all the reference signal $u_{\text{Ref}}(t)$ is obtained using direct transducer contact, e.g., without green ceramic sample. This measurement was performed using the described above dry acoustic contact with a vinyl film. That enabled eliminate additional delay of the ultrasonic signal in the ultrasonic transducers and in the vinyl film. Two time instances t_1' and t_1'' were measured in the reference signal using polynomial approximation in the zero-crossing zone (Fig. 3). After that the ultrasonic signal $u_{\text{Tile}}(t)$ was measured in center of the samples of green ceramic tile and corresponding zero-crossing instances t_2' and t_2'' determined. In the case when there is no essential frequency depended attenuation in material of the sample the delay time differences $t_2' - t_1'$ or $t_2'' - t_1''$ determine propagation time in the tested sample. However in the case

of green ceramic tile the attenuation is strongly frequency dependent. As can be observed in Fig. 3 the frequency of the signal propagated through sample is much lower due to strongly suppressed higher frequency components of the signal. In this case estimation of propagation just from time differences $t_2' - t_1'$ or $t_2'' - t_1''$ will lead to big errors.

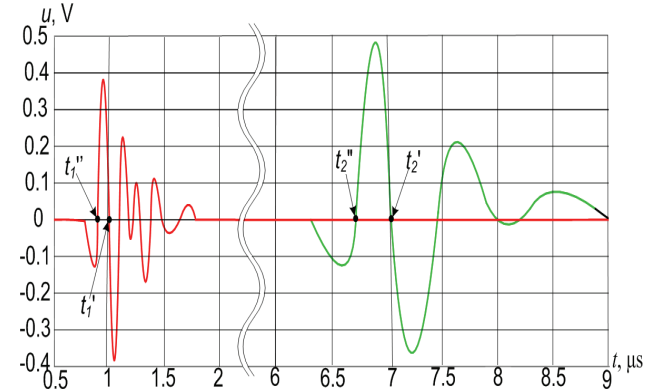

Fig. 3. The reference signal (left) and the signal measured on the sample of green ceramic tile (right) with denoted measured zero-crossing time instances

In order to compensate these errors it was proposed the following algorithm:

1. The segment of the signal up to the second measured zero-crossing point was selected using rectangular time window both in the reference signal and signal measured on sample:

$$u_{\text{Ref},0}(t) = \begin{cases} u_{\text{Ref}}(t), & t \leq t_1' \\ 0, & \text{otherwise,} \end{cases} \quad (5)$$

$$u_{\text{Tile},0}(t) = \begin{cases} u_{\text{Tile}}(t), & t \leq t_2' \\ 0, & \text{otherwise;} \end{cases} \quad (6)$$

2. The frequency spectrum of both of the segments were calculated using Fourier transform:

$$U_{\text{Ref},0}(f) = \text{FT}[u_{\text{Ref},0}(t)], \quad (7)$$

$$U_{\text{Tile},0}(f) = \text{FT}[u_{\text{Tile},0}(t)], \quad (8)$$

where FT denotes Fourier transform;

3. The frequency corresponding to the maximum of the spectrums were estimated:

$$f_{\text{Ref,max}} = \arg\{\max[U_{\text{Ref},0}(f)]\}, \quad (9)$$

$$f_{\text{Tile,max}} = \arg\{\max[U_{\text{Tile},0}(f)]\}; \quad (10)$$

4. The equivalent period of the signals were calculated:

$$T_{\text{Ref}} = 1/f_{\text{Ref,max}}, \quad (11)$$

$$T_{\text{Tile}} = 1/f_{\text{Tile,max}}; \quad (12)$$

5. Then the compensated propagation time in the sample of green ceramic tile can be estimated according

$$t'_{\text{Tile}} = t_2' - t_1' - (T_{\text{Tile}} - T_{\text{Ref}}), \quad (13)$$

or

$$t''_{\text{Tile}} = t_2'' - t_1'' - (T_{\text{Tile}} - T_{\text{Ref}})/2. \quad (14)$$

In order to estimate how efficient compensation is the reference signal is shown on Fig. 4 together with the signal

measured on the green ceramic tile, but shifted back according measured delay time. As can be seen best estimation time is obtained using second measured zero-crossing time instance and Eq. (13).

Then the longitudinal ultrasound velocity was calculated as

$$c_{zc} = d_m / t'_{Tile}, \quad (15)$$

where d_m is the measured sample thickness at the measurement point.

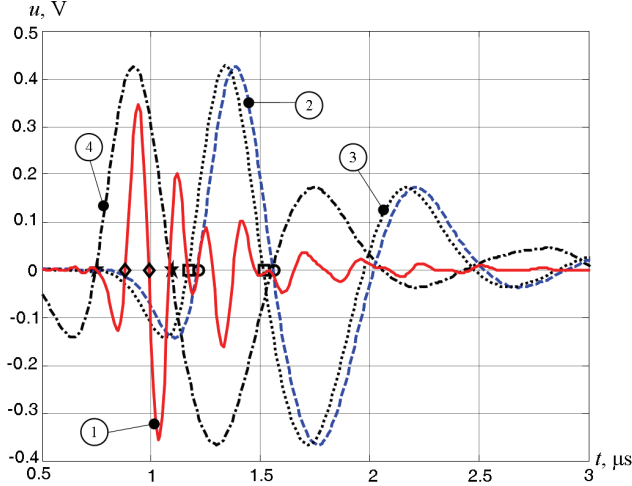

Fig. 4. Measured ultrasonic signals: 1- the reference signal, 2 - signal obtained on the sample; but shifted back in time domain using the delay time estimated according Eq. (14); 3 - signal obtained on the sample, but shifted back in time domain using the delay time estimated according Eq. (13); 4 - signal obtained on the sample, but shifted back in time domain using the delay time estimated using cross-correlation technique

It is necessary to point out that method based on zero-crossing is susceptible to noise, therefore for measurements we also applied method based on a cross-correlation.

Cross-correlation technique is most reliable and accurate and is based on calculation of a cross-correlation function between the reference and the measured signal. In this case, the reference signal is the same as using the zero-crossing technique.

Using the cross-correlation technique the ultrasonic wave propagation speed was calculated in the following steps. The cross-correlation function $y_{cc}(t)$ between the signal $u_{Ref}(t)$ and $u_{Tile}(t)$ is given by [12]

$$y_{cc}(t) = \frac{1}{T} \int_0^T u_{Tile}(t) \cdot u_{Ref}(t - \tau) d\tau, \quad (16)$$

where τ is the integration variable, T is total duration of the recorded signal (1–5 μ s).

Determination of the maximum of the cross-correlation function [13–15] t_{cc} corresponding to the time delay between the signals $u_{Ref}(t)$ and $u_{Tile}(t)$ is performed in the following way [12]

$$t_{cc} = \arg\{\max[y_{cc}(t)]\}. \quad (17)$$

Then longitudinal ultrasound velocity was calculated as

$$c_{cc} = d_m / t_{cc}. \quad (18)$$

As can be seen in Fig. 4 the delay time estimation using this technique leads to the systematic error caused by attenuation. On the other hand the additional filtering of the reference signal can be used in order to reduce errors. However for that the attenuation dependency on frequency should be known, what is not determined strictly and can be different for samples of different ceramics.

The measurements were carried out at the ambient temperature T ($T = 20.4$ °C) and humidity θ ($\theta = 50$ %). In fact, humidity content of the object also affects the propagation speed of ultrasound, but its influence is not significant, because measurements are made with dried tiles at the constant humidity level (4 - 5) %.

Usually temperature and humidity of the manufacturing environment are not measured on-line, hence, in the case of on-line measurements an additional uncertainty occurs. If the influence of temperature T and humidity θ are taken into account, the longitudinal ultrasound velocity c_L is given by [16]

$$c_L(T, \theta) = (c + 0.59T) \left(1 + 0.004 \frac{\theta}{100} \right). \quad (19)$$

In our case velocity values (c_{zc} and c_{cc}) are calculated using Eq. (15) and Eq. (18). The uncertainty of these measurements is calculated from the measurement results by evaluating all factors which affect the measurement of c_{zc} and c_{cc}

$$u_c = \sqrt{W_{d_m}^2 \cdot u_{d_m}^2 + W_{t_{Tile}}^2 \cdot u_{t_{Tile}}^2}, \quad (20)$$

where $u_{t_{Tile}} = f\{f_s, \Delta t_d, SNR, AC\}$ is the measurement uncertainty of ultrasound propagation time, f_s is the signal frequency, Δt_d is the ADC time sampling step, SNR is the signal to noise ratio and AC estimates stability of the dry acoustic contact.

For example the ultrasound velocity c_{zc} and c_{cc} , calculated the tile density ρ and the uncertainty u_{zc} and u_{cc} in the sample 1 (Fig. 5) were measured as follows.

First of all the sample thickness was measured by a micrometer ($d_m = 8.19$ mm \pm 0.01 mm) and then the longitudinal ultrasonic wave propagation times $t'_{Tile} = 5.6$ μ s \pm 12.0ns, $t''_{Tile} = 5.7$ μ s \pm 12.0ns and $t_{cc} = 6.1$ μ s \pm 15.0ns) were measured by using the computerized measuring system.

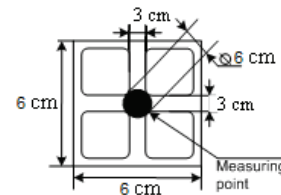

Fig. 5. Green ceramic sample (dimensions are given in mm) and the measuring point of the longitudinal ultrasonic wave propagation time t_m

Finally, the velocity of longitudinal ultrasonic waves was calculated using Eq. (15) and Eq. (18), with gives a systematic error of 112 m/s. From the obtained c_{zc} and c_{cc} measurements results their uncertainty were estimated:

$$u_{c_{zc}} = \sqrt{u_{d_m}^2 + u_{t_{Tile}}^2} = 3 \text{ m/s}, \quad (21)$$

$$u_{c_{cc}} = \sqrt{u_{d_m}^2 + u_{t_{Tile}}^2} = 4 \text{ m/s}. \quad (22)$$

So, the velocity of longitudinal ultrasonic waves:

$$c_{zc} = \frac{d_m}{t_{Tile}} = 1463 \pm 6 \text{ m/s}, \quad (23)$$

$$c_{cc} = \frac{d_m}{t_{cc}} = 1455 \pm 8 \text{ m/s}. \quad (24)$$

Then, a small rectangle test samples (s_1, s_2, s_3 and s_4) were cut out from this tile to determined relationship between obtained c_{zc} and c_{cc} values and the density. Subsequently they were weighed, measured its size, and calculated their density. Then was measured the ultrasonic wave propagation velocity in the middle of these samples. Obtained data presented in Table 1.

Table 1. Analysis results of tested samples

	c_{zc} , m/s	c_{cc} , m/s	ρ , kg/m ³
s_1	1461	1457	1860
s_2	1463	1458	1863
s_3	1470	1461	1869
s_4	1470	1463	1871

So, the linear relationship between the tested sample density and the ultrasonic wave propagation velocity in the samples were determined using approximation. Exploiting this relationship the density of a sample (1) was calculated for two cases (c_{zc} and c_{cc}):

$$\rho'(c_{zc}) = 1.066c_{zc} + 303.4 = 1863 \text{ kg/m}^3 \pm 6\text{kg/m}^3, \quad (25)$$

$$\rho''(c_{cc}) = 1.606c_{cc} - 478.9 = 1858 \text{ kg/m}^3 \pm 8\text{kg/m}^3. \quad (26)$$

The uncertainty of the longitudinal ultrasound wave propagation speed measurement was changed to the uncertainty of a sample density measurement, because the apparent density ρ was calculated by exploiting relationship with the ultrasonic propagation velocity.

From the ultrasonic longitudinal wave velocity measurements, performed at different points according to Fig. 1b, two-dimensional spatial distribution of the velocity $c_L(x,y)$ was obtained (Fig. 6). Correspondingly, using the procedure described above, two-dimensional spatial distribution of the density $\rho(x,y)$ was calculated. Intermediate values between measurement points were obtained by interpolation (Eq. (4)).

From the results presented follows that the longitudinal wave velocity and, correspondingly, the density of green ceramic tiles depend on spatial

coordinates in-plane of tiles. These spatial variations may influence quality of tiles, because after baking procedure they may cause deformation of tiles.

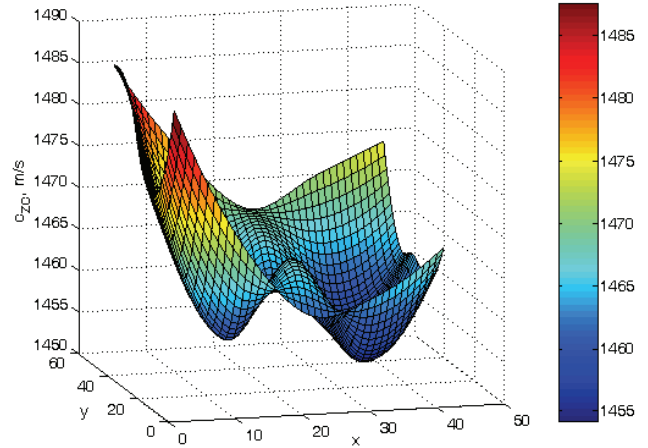

Fig. 6. Spatial variations of the ultrasound velocity c_{zc} measured across a green ceramic tile

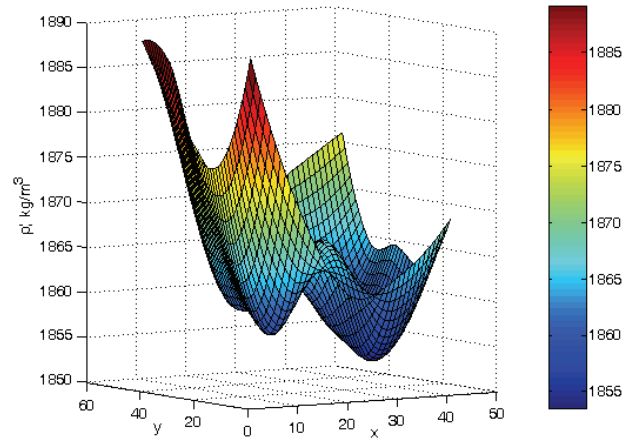

Fig. 7. Spatial variations of the density ρ' of green ceramic tile

Conclusions

1. For quality monitoring of ceramic tiles during manufacturing process, estimation of the density spatial variations, based on measurement of the ultrasonic longitudinal wave velocity, may be efficiently used.
2. The longitudinal ultrasonic wave velocity may be measured by using zero-crossing and/or cross-correlation techniques.
3. In the case of the high signal to noise ratio and stable amplitude of the received ultrasonic signals the zero-crossing technique is more preferable than the cross-correlation technique as a simpler one.

However it was found that by using the zero-crossing technique and performing measurements at different zero-crossings some systematic error occurs. For example, when the ultrasonic wave propagation time t_{zc} is measured between full signals period and between half signals period, the obtained c_{zc} values are correspondingly 1463 m/s and 1452 m/s, e.g., there is difference ~ 11 m/s in all measured cases. This difference may be eliminated by an appropriate calibration procedure.

4. The spatial distribution of the thickness d_m was measured by a micrometer and this uncertainty is highest of all uncertainties. The average thickness deviation across the whole tile is $\sim 2.5 \mu\text{m}$.
5. Experimental verification of this technique carried out in laboratory conditions shows that it is necessary to perform more detailed the measurements of various tiles in order to determine optimal number of measurement points, which is enough for a reliable reconstruction of spatial distribution of a green ceramic density.
6. **Engmann D.** Quality testing of green ceramic tiles: Measurement principles for determining bulk density // *Interceram*, 2000. – Vol. 49, No. 4. – P. 250–253.
7. **Rabe T., Rudert R., Goebbels J., Harbich K.–W.** Nondestructive evaluation of green components // *American Ceramic Society Bulletin*, 2003. – Vol. 82, No. 3. – P. 27–32.
8. **Patent WO/2003/032096.** Method of volume manufacture of a product in a staged production process, 17.04.2003. – 77 p.
9. **Tietz H. D., Dietz M., May B., Buhling L.** Ultrasonic testing of green ceramic materials // *NDT.net*, 1997. – Vol. 2. – No. 10.
10. **Revel G. M.** Measurement of the apparent density of green ceramic tiles by a non-contact ultrasonic method // *Experimental Mechanics*, 2007. – Vol. 47. – P. 637–648.
11. **Kažys R.** Neelektrinių dydžių matavimas. – *Vitae Litera*, 2007. – 283 p.
12. **Kažys R., Raišutis R., Šliteris R., Mažeika L., Jasiūnienė E.** Ultrasonic thickness measurement of the aluminum plate with wavy surface // *Ultragarsas*, 2004. – Nr. 1(50). – P. 11–16.
13. **Lai X., Torp H.** Interpolation methods for time delay estimation using cross-correlation for blood velocity using cross-correlation method for blood velocity measurement // *IEEE Transactions on Ultrasonics, Ferroelectrics and Frequency Control*, 1999. – Vol. 46. – P. 277–290.
14. **Korte C. L. Van der Steen A. F. W.** Performance of time delay estimation methods for small time shifts in ultrasonic signals // *Ultrasonics*, June 1997. – Vol. 35. – Iss. 4. – P. 263–274.
15. **Cespedes I., Huang Y.** Methods for estimation of subsample time delays of digitized echo signals // *Ultrasonic Imaging*, April 1995. – Vol.17. – Iss. 2. – P.142–171.
16. **Cramer O** The variation of the specific heat ratio and the speed of sound in air with temperature, pressure, humidity, and CO₂ concentration // *The Journal of the Acoustical Society of America*, 1993. – Vol. 93. – No. 5. – P. 2510–2516.

Acknowledgments

We would like to thank dr. R. Šliteris for the help during experiments.

References

1. ISO 10545-3:1995, Ceramic tiles - Part 3: Determination of water absorption, apparent porosity, apparent relative density and bulk density, 90.60. – 3 p. (2010–09–17).
2. **Revel G. M., Tomasini E. P.** Non-contact ultrasonic sensor for on-line density measurement on green ceramic tiles // 15th World Conference on Nondestructive Testing. – Roma, Italy, October 2000. Online: <<http://www.ndt.net/article/wcndt00/papers/idn708/idn708.htm>> (2011-03-20).
3. **Amoros J. L.** Clay ceramics for floors single firing. Influence of variables of pressing on the properties of the part in oil and on their behavior during the press and cooking, PhD Thesis. – University of Valencia, 1987. – 61 p.
4. **Kathrina T., Rawlings R. D.** Non-destructive evaluation of porous MgO ceramics using acoustic techniques // *Journal of material science*, 1997. – Vol. 32. – P. 3951–3959.
5. **Pei P., Bhardwaj M. C., Anderson J., Minor D., Thornton T.** Measuring green body density // *Ceramic industry*, 2000.

Received 2011 04 29

M. Kulokas, R. Kazys, L. Mazeika. Non-Destructive Evaluation of Green Ceramic Body Density by Ultrasonic Technique // Electronics and Electrical Engineering. – Kaunas: Technologija, 2011. – No. 5(111). – P. 71–76.

Laboratory measurements of spatial density distribution in green ceramic tiles were implemented using ultrasonic contact coupling measurement method. The main objective of these measurements is to measure spatial density distribution in pressed green ceramic tiles. Measurements of longitudinal ultrasonic wave propagation velocity were carried out using pulse and correlation methods and the tile density values were calculated. Evaluation of the measurement method, estimation of uncertainty of measurements and analysis of further improvements purposed to adapt it for on-line measurements in a production process were carried out. Ill. 7, bibl. 16, tabl. 1 (in English; abstracts in English and Lithuanian).

M. Kulokas, R. Kažys, L. Mažeika. Neardomųjų žalios keraminės plytelės tankio matavimo ultragarsu analizė // Elektronika ir elektrotechnika. – Kaunas: Technologija, 2011. – Nr. 5(111). – P. 71–76.

Presuotų keraminių plytelių ruošinių tankio erdviniam pasiskirstymui matuoti laboratorinėmis sąlygomis taikytas ultragarsinis tiesioginio kontakto matavimo metodas. Svarbiausias šių matavimų uždavinys – nustatyti visų presuotų keraminių plytelių ruošinių tankio erdvinį pasiskirstymą. Eksperimentų metu išilginių ultragarso bangų sklaidimo greičio matavimai atlikti taikant impulsinį ir koreliacinį metodą, o plytelės tankio vertės apskaičiuotos išnaudojant ryšį tarp ultragarso greičio ir plytelių tankio. Matavimų rezultatams įvertinti apskaičiuotos neapibrėžtys, įvertintas pats matavimo metodas ir numatyta, kaip jį toliau tobulinti ir pritaikyti matavimams gamybos linijoje. Il. 7, bibl. 16, lent. 1 (anglų kalba; santraukos anglų ir lietuvių k.).