

Effective Control of a Battery Supplied Mine Locomotive Unit

B. Polnik¹, Z. Budzynski¹, B. Miedzinski²

¹*Division of Drives and Control Systems, Institute of Mining Technology KOMAG,
Pszczynska St. 37, 44-101 Gliwice, Poland*

²*Institute of Innovative Technologies, EMAG,
Leopolda St.31, 40-189 Katowice, Poland
bpolnik@komag.eu*

Abstract—The paper discusses the advantages and disadvantages of existing mining locomotive propulsion systems used in the Polish underground mines. The method to design a new propulsion system with recuperation of energy is presented. Conclusions and recommendations for necessity of controlling the volume of recuperated energy closely correlated with amount of electrolytic gas emissions are given.

Index Terms—Battery supply, mine locomotive unit, energy recuperation, drive, PMSM.

I. INTRODUCTION

Battery powered locomotive is one of the means for transportation of people, ore and materials in underground mines. Their main advantage is lack of emission of exhaust gases what is a main problem in the case of using the diesel locomotives in mines. Battery supplied drives do not require a special maintenance apart from replacing the batteries after discharge. Their operation time is only limited by the battery capacity.

Lea BM-12 locomotives (Fig. 1) are the most popular in Polish mines.



Fig. 1. Battery supplied mining locomotive Lea BM-12 [1].

These locomotives operate since a long time, as they were

manufactured from 1970ties. Now their production is stopped and they can only be repaired and modernized. It should be noted that in the Polish mining industry several other solutions of the locomotives can be found, but none of them became popular enough. The main technical parameters of Lea BM-12 locomotive are presented in Table I.

TABLE I. RATED TECHNICAL PARAMETERS OF THE LEA BM-12 LOCOMOTIVE [2].

Total weight	12t
Width of the track	600÷950 mm
Tractive force for 1-hour	16,8 kN
One hour speed	8 km/h
Maximum speed	16 km/h
Motor power of 1-hour	38 kW
Number of motors	1
Battery voltage	144 V
Battery capacity	760 Ah
Degree of protection	IP 54

Single electric motor is used in the existing drives of the Lea BM-12 locomotive. It is a series DC motor (type LDS245) of rated power equal to 15 kW and instantaneous power up to 38 kW. It drives the shaft of the locomotive from both ends simultaneously (by the relevant mechanical gear) what is a big advantage compared to other solutions where, either one axle is driven or two independent motors with less power are used. Supply and rotary speed control is based on DC thyristor switch, which is DC/DC converter of forced-commutation. It can operate in a switch on or switch off position for any time interval. The power-electronic key allows for smooth step less motor startup and energy recovery to the traction cells. Start up and run is realized at current in the range from 80 A to 295 A, current braking at current 80 A to 200 A while, emergency braking (by means of dead-means handle) at current 150 A. Control system realizes the function of reduction of field excitation, at the last step of speed controlling device (run at 240 A). Since power supply is unidirectional the change of direction of the motor rotation is effected by means of reversing contactors system, while braking by using the VM4 diode (see Fig. 2). To make the engine braking more effective, it is overexcited from the battery through R_w resistor.

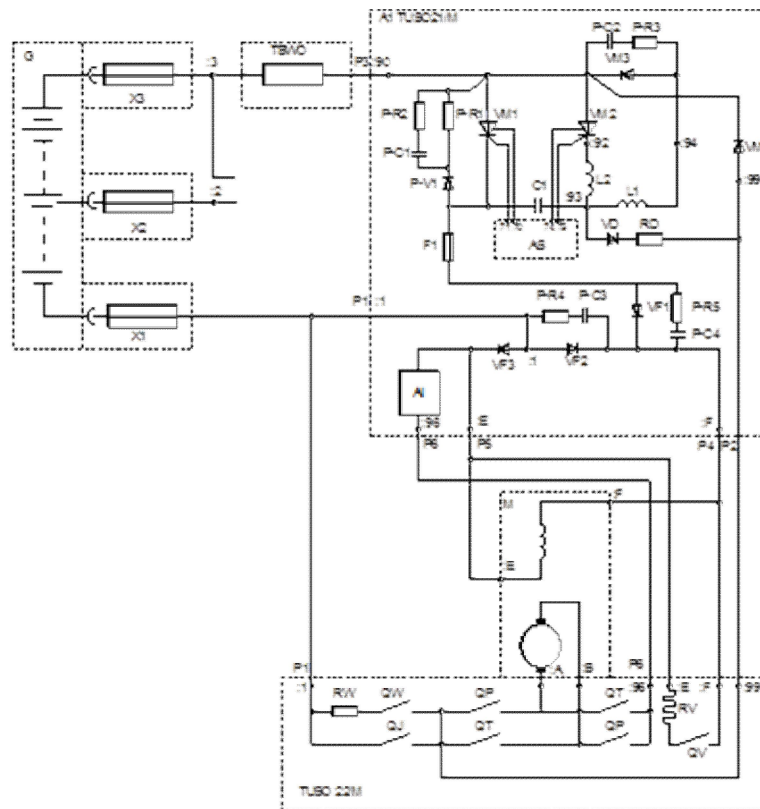

Fig. 2. Scheme of the main electric circuit of the Lea BM-12 locomotive [3].

At present the expectations and needs of users of battery supplied mine locomotives are much higher. There are the following basic requirements:

- long enough time of operation without necessity of changing batteries,
- charging system should be compatible with that used in mine,
- high tractive force to enable transporting heavy weight loads,
- high speed of transportation,
- high reliability.

To satisfy the above requirements one needs to apply new solutions regarding the driving system structure and make appropriate modifications concerning effective control of energy recuperation level strongly related to electrostatic gas emission volume. Paper presents and discusses results of such undertaken measures and formulates conclusions and

recommendations for operation in practice.

II. SOLUTION OF THE NEW DRIVE SYSTEM

Experts from KOMAG Institute of Mining Technology and Institute of Innovative Technology, EMAG, Poland decided to jointly undertake the modernization of the existing locomotive propulsion system. Therefore, a new concept for drive system to be installed directly in the Lea BM-12 locomotive without making any changes to these machines has been developed. Experts made a lot of stand tests. One of them was comparing the PMSM motor and IM motor (Fig. 3 and Fig. 4). Why those? After comparing simulations between asynchronous, synchronous and direct current motors, the results shows that alternating current motors are better for our applications, than the direct current motor.



a)

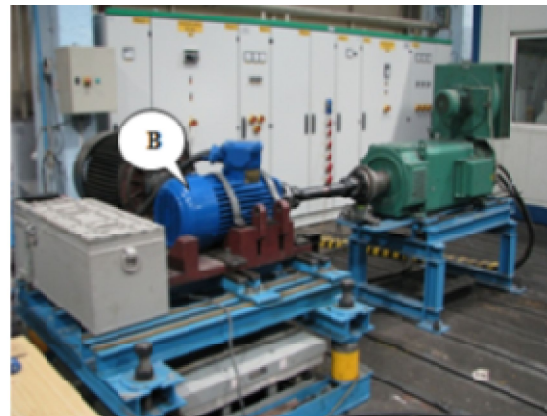

b)

Fig. 3. Tests station [4]. A – brushless permanent magnet synchronous motor SMwsd 200 S-4, B – inductive motor dSkg 180L4-EP-f.

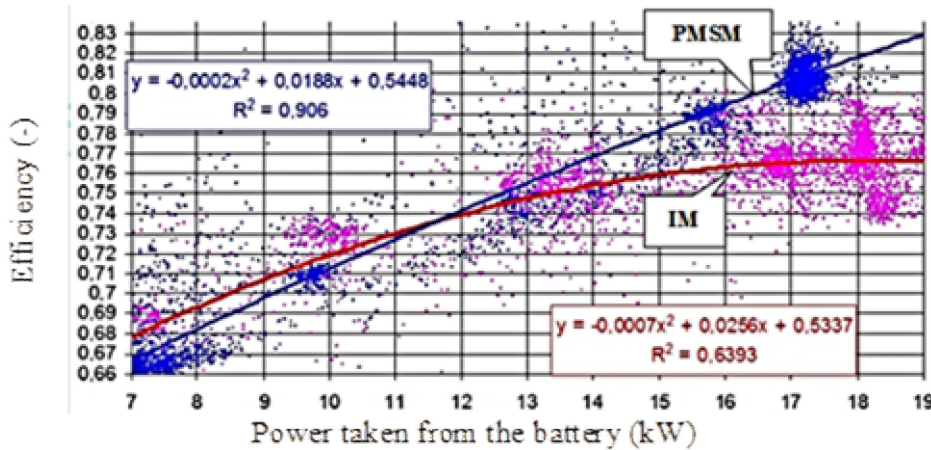

Fig. 4. Process of efficiency against power taken from the battery [4].

In a result of all of the tests, the series DC motor was eliminated and replaced by two brushless permanent magnet synchronous motors (PMSM). The main advantages of IM over DC machine for the same performance are low cost, robustness and reliability [5]–[8] also the permanent magnet synchronous motor has the advantages such as large energy density, high efficiency, long service life and low complexity [9]–[14]. The control system was modified as well by application of two independent power electronic converters. Proper vector control of motors has been used with current control in the q-axis of machine during start-up and braking. This is a typical two-zone control, where, for basic frequency of 50 Hz a constant magnetic flux is maintained by setting the constant current in the d-axis of the machine (responsible for the motor excitation). While, above this frequency the magnetic flux is reduced in inverse proportion to the increase of the frequency by controlling the current in d-axis. This type of control allows providing constant torque produced by the motor in the first zone and constant mechanical power in the second zone. Voltage inverter composed of 6-pulse bridge with reverse diodes was used for the machine supply. The last element subjected to modernization was a source of electric energy - battery. According to PN-EN 60079-7:2010 standard “secondary batteries must be lead-acid, iron-nickel, nickel-cadmium”. This clause is applied to secondary cells of a capacity of more than 25 Ah [3]. It was therefore, decided to use the same type of lead-acid cells but of increased capacity from 760 Ah up to 1000 Ah what, results in increase of effective energy from 109.44 kWh to 144 kWh. To improve energy efficiency of the recommended propulsion system it is necessary to increase as much as possible the energy recovered during electrical braking. However, it must be taken into account that during charging of lead-acid cells (braking with electrical energy recovery) accompanying the chemical reactions can be dangerous, especially in the case of high intensity charging. During charging lead sulphate (PbSO_4) is decomposed on the negative potential plate (cathode) of the cell. When charging the lead sulphate (PbSO_4) on the cathode, is reduced to “spongy” lead. While acid ion SO_4^{2-} with hydrogen ion increase concentration of H_2SO_4 acid. On the positive potential plate (anode) the lead sulphate decomposes. Electrochemical decomposition of lead sulphate opens the pores of the active mass of

electrodes, allowing the diffusion of concentrated sulphuric acid into them. The diffusion of the electrolyte in the pores increases concentration of sulphuric acid, decreases the internal resistance, and increases EMF value of a cell [3]. These are the typical chemical processes, which, under normal use of the battery should not be any danger to users [15]. However, when charging the so-called parasitic, side reactions take place as well. Namely on the cathode hydrogen can be generated. While, on the anode – oxygen O_2 respectively. Release of hydrogen and oxygen is a result of the water hydrolysis. Reactions taking place in acid cells with gas emission to the atmosphere (mainly hydrogen) may cause a significant risk of explosion, especially in dusty and methane mines [3]. Therefore, it was necessary to carry out the tests and simulation analyses to find expected value of the return current to the batteries during various braking torque corresponding to a real drive system. Since, the developed driving system is composed of two inverter-synchronous motors with permanent magnets (PMSM), which are evenly loaded, the simulations can be simplified to a single motor model assuming its load reduced to half load of the locomotive. For the applied motors (SMwsd 200S-4 type) the load is represented by a resultant load torque (T) and moment of inertia (J) values at the motor shaft, taking into account both the mechanical gear parameters as well as the locomotive wheels diameter (0.6 m). These values (for a single motor) are as follows: for the loaded train (decline 0.4 %): $T_{\text{load}} = 49.5 \text{ Nm}$, $J_{\text{load}} = 14.5 \text{ kgm}$, for the empty train (rise 0.4 %): $T_{\text{empty}} = 67.6 \text{ Nm}$, $J_{\text{empty}} = 6.075 \text{ kgm}$. Simulation model of the drive has been implemented in Matlab-Simulink modifying the PM Synchronous Motor Drive block of the SimPowerSystems library (see Fig. 5).

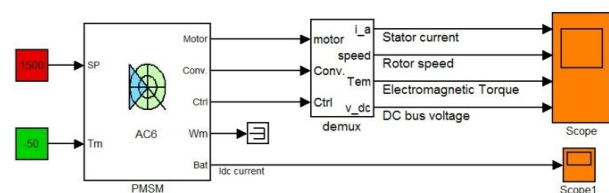

Fig. 5. Graphical representation of the simulation model in Matlab-Simulink.

The modification had to change the way of power supply with three-phase voltage source for battery pack of parameters consistent with these for the battery used in a real

system (Fig. 6).

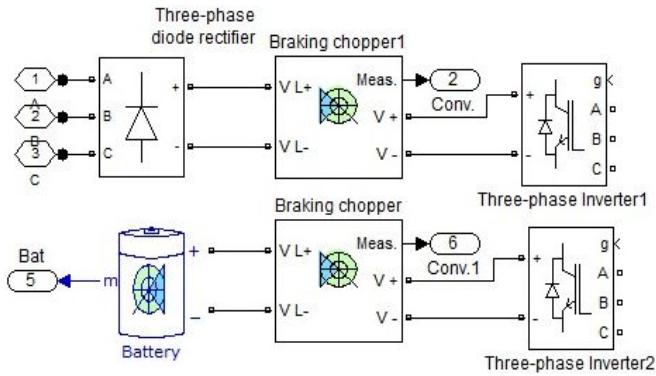

Fig. 6. Modification of the driving system.

PMSM motor model (SMwsd 200 S-4 type) was developed on the basis of its required technical data (rated power 19 kW, rated voltage 88 V, rated rotational speed 1500 rpm. etc.) entered to block PM Synchronous Motor Drive. For example, Fig 7 shows the current waveforms during braking (at energy recovery) for different values of braking torque (T) at constant speed equal to 750 rpm. The current, which is returned to the battery by a single motor varies from 16 A to 40 A. For two motors this value will be

doubled and it was found that it corresponds well with the values measured in a real locomotive drive system.

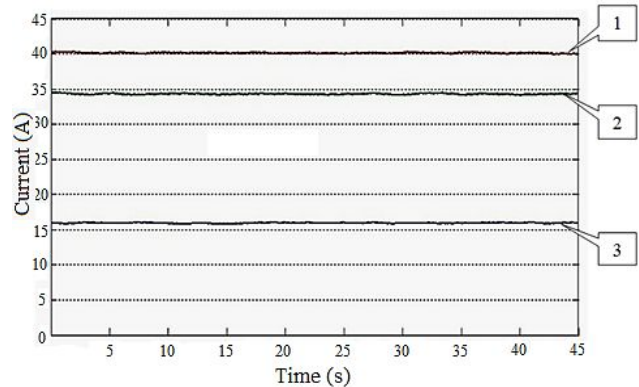

Fig. 7. Current waveform at different braking torque T values at a constant speed equal to 750 rpm. 1 - $T = 90$ Nm, 2 - $T = 70$ Nm, 3 - $T = 30$ Nm.

III. EFFECTIVE CONTROL OF A BATTERY SUPPLIED MINE LOCOMOTIVE UNIT

Hydrogen emission that occurs during battery recharging process requires compromising the desired efficiency while, ensuring highest number of operation cycles and maximum safety in terms of electrolytic gas emission.



Fig. 8. Modernized Lea BM-12 locomotive with transportation load in a form of diesel locomotive [7].

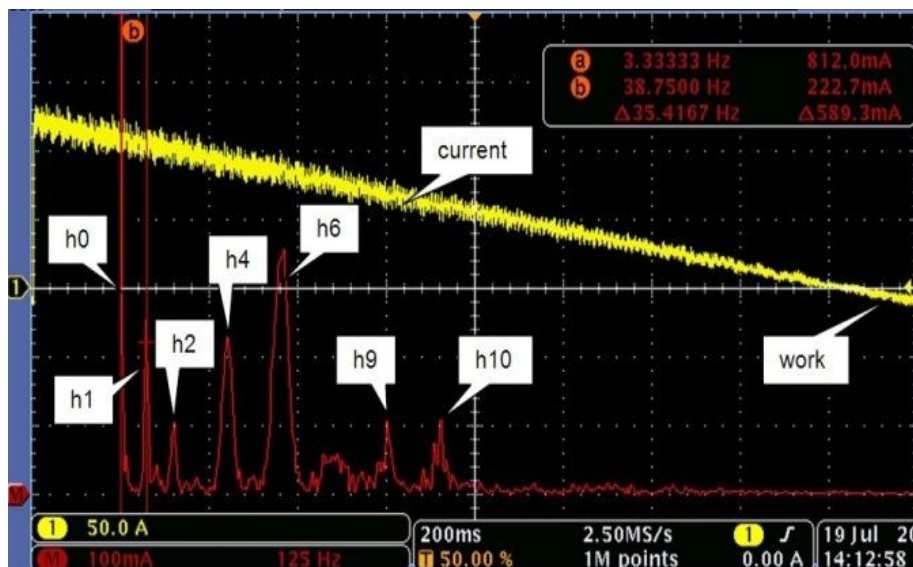

Fig. 9. Current waveform during the braking process with FFT analysis results [7].

The use of two synchronous motors with permanent magnets controlled by independent voltage invertors has improved significantly electric efficiency of the Lea BM-12 locomotive and thus allowing effective recovery of energy in much wider range of operation. However, recuperation of greater amount of energy (increase of locomotive life) is related with the risk resulting from increased emission of gases, especially hydrogen. Therefore, it became necessary to carefully analyse and examine the total process of braking with energy recuperation to the battery. It is known that the gas emission is strictly related to the current flowing through the battery. Therefore, to better understand the phenomena during the process of charging, some investigations were carried out for the modernized locomotive under real working conditions in the mine. For this purpose, in a selected mine, the locomotive equipped with a new battery drive system was installed as in Fig. 8. For the purpose of testing, the system was composed of a single electric motor and a single inverter.

The loaded locomotive was accelerated to a speed close to real value (about 3 m/s) and then electrically braked at constant torque with recording the curve of flowing current until the stop. To determine the level of current deformation due to harmonics contents during energy recovery, FFT analysis was made. An example of the current waveform during the test is presented in Fig. 9.

The current waveform, as it can be seen, has steep characteristics, which is associated with the first harmonic equal to 35 Hz however, expected carrying frequency for statistical current waveform at speed over 1700 rpm should be around 58 Hz. Recovery current at start of braking is about 120 A and is equal to the DC component. Such a high current results from opposite torque generated during braking from the speed 1700 rpm. up to 0 rpm. When the speed reaches zero, current moves to 3rd quarter of control chart and work starts again, but in the opposite direction (in Fig. 9. it is indicated as "work"). In addition to the DC components the six another current harmonics were recorded. The highest amplitude was found for the 6th harmonic: ($h_6 = 3.6$ A) what is equal to about 5% of current value flowing to the battery after 470 ms (210 Hz) from the beginning of recovery braking. Other recorded higher harmonic amplitudes have the following values:

$h_1 = 2.6$ A, $h_2 = 1.0$ A, $h_4 = 2.2$ A, $h_9 = 1.0$ A and $h_{10} = 10.0$ A respectively. Over the 10th harmonic there was no other visible harmonics that could affect the distortion of recovery current waveform [7].

IV. CONCLUSIONS

The use of state-of-the-art brushless electric motors with permanent magnets controlled by power converters

significantly improves the efficiency of electric locomotive extending the range of effective energy recovery during electrical braking. It is however, associated with the danger of excessive gas emission especially hydrogen, what requires application of a suitable control system correlated with acceptable volume of gas emitted. The development of such effective system requires clarifying the impact of the current value on both gas emission and battery life. Such studies are currently being conducted.

REFERENCES

- [1] Z. Budzynski, B. Polnik, "Quality of electric energy recovered during electrical braking of mine battery locomotive as one of criteria of improvement of efficiency of mining machine drive system", *XIV Konferencja Elektryki Gorniczej*, Zakopane, 2012, pp. 89–98. (in Polish).
- [2] Z. Budzynski, B. Polnik, "Mechatronic system for control and drive of battery railways designed for operation in explosive atmosphere", *Maszyny Gornicze*, vol. 2, 2011, pp. 45–51. (in Polish).
- [3] B. Polnik, "Intelligent management of energy recuperation process of mine battery locomotive", *Mechanizacja i Automatyizacja Gornictwa*, vol. 12, pp. 36–40, 2012. (in Polish).
- [4] Z. Budzynski, B. Polnik, T. Gasior, "Compare analyses between PMSM and IM mine locomotives drives", *Maszyny Gornicze*, vol. 4, pp. 31–37, 2011. (in Polish).
- [5] A. Cifci, Y. Uyaroglu, S. Birbas, "Direct field oriented controller applied to observe its advantages over scalar control", *Elektronika ir Elektrotechnika (Electronics and Electrical Engineering)*, no. 3, pp. 15–18, 2012.
- [6] A. Ejlali, D. A. Khaburi, J. Soleimani, "Sensorless field oriented control strategy for single phase line-start PMSM drive", *Electrical Review*, vol. 10, pp. 229–232, 2012.
- [7] S. Guo, J. He, "Sensorless control of PMSM based on adaptive sliding mode observer", *Int. Journal of Modelling, Identification and Control*, vol. 4, pp. 321–324, 2009. [Online]. Available: <http://dx.doi.org/10.1504/IJMIC.2009.027883>
- [8] M. S. Ahmed, N. A. A. Manap, M. Faeq, D. Ishak, "Improved torque in PM brushless motors with minimum difference in slot number and pole number", *Journal of Power and Energy Conversion*, vol. 3, pp. 206–219, 2012. [Online]. Available: <http://dx.doi.org/10.1504/IJPEC.2012.048046>
- [9] B. Polnik, "Testing on the real object the higher harmonics of current during operation of supply-and-control system of mine battery locomotive", unpublished.
- [10] T. Biskup, "Initial rotor position estimation of permanent magnet synchronous machine", *Electrical Review*, vol. 4, pp. 157–162, 2012. (in Polish).
- [11] R. Dolecek, O. Cerny, J. Novak, M. Bartłomiejczyk, "Interference in power system for traction drive with PMSM", *Electrical Review*, vol. 9, pp. 204–207, 2012.
- [12] P. Vas, *Vector control of AC machines*. Oxford: Clarendon Press, 1990.
- [13] E. Bayoumi, "Deadbeat direct torque control for permanent magnet synchronous motors using particle swarm optimization", *Int. Journal of Power Electronics*, vol. 5, pp. 301–315, 2013. [Online]. Available: <http://dx.doi.org/10.1504/IJPELEC.2013.058664>
- [14] L. Qin, X. Zhou, P. Cao, "New control strategy for PMSM driven bucket wheel reclaimers using GA-RBF neural network and sliding mode control", *Elektronika ir Elektrotechnika (Electronics and Electrical Engineering)*, no. 6, pp. 113–116, 2012.
- [15] B. Czajka, E. Jankowska, M. Baraniak, "Influence of lead alloy composition on grid corrosion in lead-acid batteries", *Corrosion Protection*, no. 4, pp. 162–164, 2013.