

# Compact Microsecond Pulsed Magnetic Field Generator for Application in Bioelectronics

V. Novickij<sup>1,2</sup>, A. Grainys<sup>1</sup>, J. Novickij<sup>1</sup>, A. Lucinskis<sup>1</sup>, P. Zapolskis<sup>1</sup>

<sup>1</sup>*Electronics Faculty, High Magnetic Field Laboratory, Vilnius Gediminas Technical University, Naugarduko St., 41, LT-03227, Vilnius, Lithuania*

<sup>2</sup>*Center for Physical Sciences and Technology, Semiconductor Physics Institute, A. Gostauto str. 11, LT-01108, Vilnius, Lithuania*  
vitalij.novickij@vgtu.lt

**Abstract**—High power pulsed magnetic field generator for application in the bioelectronics area has been developed. The developed magnetic field facility is capable of generating pulsed magnetic field up to 5 T with pulse width in the microsecond range. The maximum repetitive frequency of the pulses is 40 Hz. The generator has been implemented by application of three high power thyristor switches, capacitor bank, specifically designed load coil with crowbar diode and the control circuitry. The inductive coil that has an integrated cuvette with effective volume of 2.4  $\mu\text{l}$  for biological samples is presented in the study. Finite element analysis of the generated pulsed magnetic field and comparison to the acquired experimental pulse are performed. Experimental results of human lymphocyte cells treated by pulsed magnetic field and potential applications of the generator in the bioelectronics area of magnetoporation are discussed. Based on the results further development and improvement ways of the facility for better integration in the area of bioelectronics are proposed.

**Index Terms**—Cell membrane permeabilization, magnetic field generator, biological cells, bioelectronics.

## I. INTRODUCTION

High power electronics have found a broad array of applications in the field of bioengineering, biotechnology and biomedicine [1]. One of the most commonly used biomedical techniques is electroporation, which is used as a drug delivery tool on a cellular level [2]. This technique requires application of power electronics for generation of high intensity pulsed electric field. In traditional implementations the biological samples are fixed between a pair of electrode plates and a high power pulsed generator generates a pulse [3]. The biggest disadvantage of this method is pulse dependence on the conductivity of the medium between the plates [4]. Moreover the material of electrodes has significant influence on electrochemical reaction. Application of magnetic fields in this field gets rid of the problem, allowing equal non-contact treatment for the cells and independence of pulse parameters on the medium characteristics. But significant difference between pulse generating facilities should be taken in consideration. Compared to the high electric field generators magnetic

field generators applied in the field of bioelectronics have to be able to switch 10–20 times higher currents with repetitive frequency up to several tens of hertz. However, the methodology offers a more broad application range in bioelectronics and biomedical sciences. This work is focused on the development of a compact high pulsed magnetic field generator which is applicable in the field of bioelectronics. In order to determine the required parameters of the components of the magnetic field generator the analysis of the pulsed coil configuration and pulse parameters should be performed.

## II. SUBJECT DESCRIPTION

The principle of operation of a magnetic field generator is the discharge of capacitor bank through the load coil by application of high power semiconductor switches. The biological object is put into the cuvette inside the pulsed coil, which has a structure of a solenoid. The schematic of the pulsed magnetic field system is shown in Fig. 1.

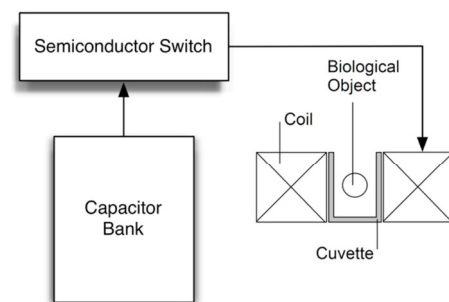

Fig. 1. The schematic of the magnetic field system.

When the treatment by pulsed magnetic field is finished one part of the sample from the cuvette is examined under the microscope, while the other part is put into the fresh vessel for further analysis. It should be noted that magnetic field in the order of 5 T with repetitive rate of 10–40 Hz must be applied for the magnetoporation to happen [5]. The required effective volume of the cuvette is limited by the critical concentration of the treated biological cells and should be at least 2  $\mu\text{l}$ , which creates a further limitation for the dimensions of the load coil. Such volume is required for further biological investigation of the samples after pulsed treatment and cannot be reduced. Therefore, acceptable parameters of the magnetic field generator should be found

such as the peak current in the circuit, capacitor bank accumulated energy level, the inductive coil configuration and the peak pulsed magnetic field value.

### III. THEORETIC APPROACH

In order to cause permeabilization of the cell membrane the transmembrane potential of the cell needs to be altered. In general case the transmembrane potential is defined as [6]

$$V_T = \frac{3}{2} E r_{cell} \cos \theta, \quad (1)$$

where  $E$  is the induced electric field,  $r_{cell}$  – the cell radius. According to Faraday's law the electric field is generated by a changing magnetic flux and is defined as

$$\oint \mathbf{E} \cdot d\mathbf{s} = -\frac{d\Phi}{dt}, \quad (2)$$

where  $\Phi = B\pi r^2$  and  $\oint \mathbf{E} \cdot d\mathbf{s} = E2\pi r$  if estimated through the integration loop with radius  $r$ , which implies that the induced electric field inside and outside the solenoid can be estimated as:

$$E = \begin{cases} -\frac{r}{2} \frac{dB}{dt}, & r < a_1, \\ -\frac{a_1^2}{2r} \frac{dB}{dt}, & r > a_1, \end{cases} \quad (3)$$

where  $a_1$  is the inner radius of the solenoid. Therefore, the transmembrane potential of the cell inside the solenoid depends both on the magnetic field peak value and the rise time of the pulse.

In general case magnetic field vector  $\mathbf{B}$  in any point  $\mathbf{r}$  due to current density  $\mathbf{j}(\mathbf{r}')$  can be found according to Biot-Savart's law

$$\mathbf{B}(\mathbf{r}) = \frac{\mu_0}{4\pi} \int_V \frac{\mathbf{j}(\mathbf{r}') \times |\mathbf{r} - \mathbf{r}'|}{|\mathbf{r} - \mathbf{r}'|^3} d\mathbf{r}', \quad (4)$$

where  $\mu_0$  is the permeability of free space.

However, if the geometric parameters of the solenoid are known, another approach of the magnetic flux density calculation could be applied and the peak value of the magnetic field in the solenoid could be estimated from [7]

$$B = \mu_0 \frac{NI}{2\beta a_1} F(\alpha, \beta), \quad (5)$$

where  $a_1$ ,  $a_2$  are the inner and outer radiuses of the coil, respectively,  $b$  is the half of the inductor length,  $\alpha = a_1/a_2$  and  $\beta = b/a_1$ ,  $I$  is the current,  $N$  is the number of windings,  $F(\alpha, \beta)$  is the form factor and is defined as

$$F(\alpha, \beta) = \frac{\beta}{\alpha - 1} \ln \frac{\alpha + \sqrt{\alpha^2 + \beta^2}}{1 + \sqrt{1 + \beta^2}}. \quad (6)$$

In order to define the current the electric circuit parameters such as resistance, capacitance and inductance should be evaluated. The resistance and inductance could be estimated as follows:

$$R = \frac{\pi \rho (\alpha + 1)}{2a_1 \lambda \beta (\alpha - 1)} N^2, \quad (7)$$

$$L = \mu_0 a_1 \frac{\pi (\alpha + 1)^2}{8\beta} N^2 F(\alpha, \beta), \quad (8)$$

where  $\lambda$  is the filling factor and  $\rho$  is the resistivity.

Discharging the capacitor bank through the inductive coil by application of the thyristor switch a pulsed current will generate pulsed magnetic field. If the inductive coil has a crowbar diode in parallel the on/off-state positions could be expressed separately using differential equations [8]:

$$U_{off} = \left\{ \begin{array}{l} (R_{line} + R_{switch} + R_{coil})(i(t)) + \\ + (L_{line} + L_{coil}) \frac{di(t)}{dt} + \frac{1}{C} \int i(t) dt \end{array} \right\}, \quad (9)$$

$$U_{on} = 0 = \left\{ \begin{array}{l} (L_{line} + L_{coil}) \frac{di(t)}{dt} + \\ + (R_{line} + R_{crowbar} + R_{coil}) i(t) \end{array} \right\}, \quad (10)$$

where  $R$ ,  $L$  are the resistance and inductance of the line, coil, switch and crowbar in on-state condition, respectively;  $C$  – capacitance of capacitor bank and  $i$  is the current.

The current could be estimated by solving differential equations. The current is equal to:

$$I_{off} = \frac{U}{\omega L} \exp\left(-\frac{R}{2L}t\right) \sin \omega t, \quad (11)$$

$$I_{on} = I_{max} \exp\left(-\frac{R}{L}t\right), \quad (12)$$

where  $\omega = \sqrt{\frac{1}{LC} - \frac{R^2}{4L^2}}$  is the oscillation frequency,  $I_{max}$  is

maximum value of the current oscillations when crowbar diode is still in the off state condition.

Finally the transmembrane potential could be defined as a complex function of various parameters

$$V_T = \psi(R, L, C, N, \alpha, \beta, \lambda, \rho, a_1, a_2, b). \quad (13)$$

Most of them are difficult to express analytically. Moreover, during the discharge the pulsed coil is heated and the resistance  $R$  has a non-linear dependence on temperature and such technical data as conductor configuration, thickness of inner windings and inner layer insulation, filling factor influence on the coil parameters are also not included in the analysis. Therefore, numerical methods such as finite element method analysis were applied.

### IV. PULSED MAGNETIC FIELD GENERATOR

Based on the simulation the pulsed magnetic field

generator has been developed. The summary of simulated output parameters of the pulsed magnetic field generator is presented in Table I.

TABLE I. SIMULATED OUTPUT PARAMETERS FOR THE MAGNETIC FIELD GENERATOR.

Parameter	Denotation	Value
Magnetic flux density	$B$ , T	5 T
Pulse width	$\Delta t$ , $\mu\text{s}$	4 $\mu\text{s}$
Rise time	$t_R$ , $\mu\text{s}$	$t_R < 2 \mu\text{s}$
Repetitive frequency	$f$ , Hz	Up to 40 Hz
Number of pulses	$n_{max}$	300

According to FEM analysis the coil configuration has been selected to be 5-layer solenoid with 5 windings in each layer. For winding insulated wire of 0.35 mm diameter was chosen. Based on simulation in such configuration pulsed coil has  $a_1 = 0.5$  mm inner radius,  $a_2 = 4$  mm outer radius,  $b = 3$  mm of height, total inductance of 1.7  $\mu\text{H}$ . The inner volume of the solenoid is 2.4  $\mu\text{l}$ . The peak current that is required to generate magnetic field of 5 T is in the range of 500 A. The distribution of the magnetic flux density and the structure of the developed pulsed coil are shown in Fig. 2.

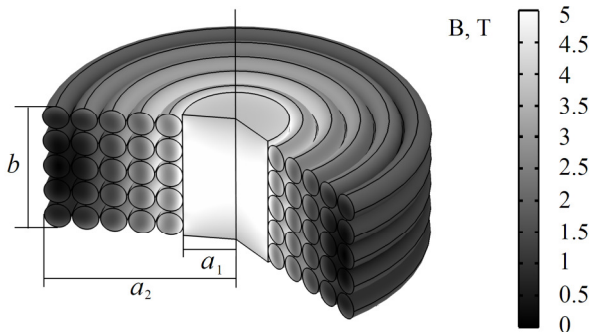

Fig. 2. The distribution of magnetic flux density and the structure of the resultant load coil.

Non-homogeneity in central area does not exceed 10 percent and is acceptable for most bioelectronic experimentations. Pulsed generator consists of high power fast thyristor switches, capacitor bank, high voltage source, the load coil and drivers for controllable pulse generation.

The simplified schematic of the pulsed magnetic field generator is shown in Fig. 3.

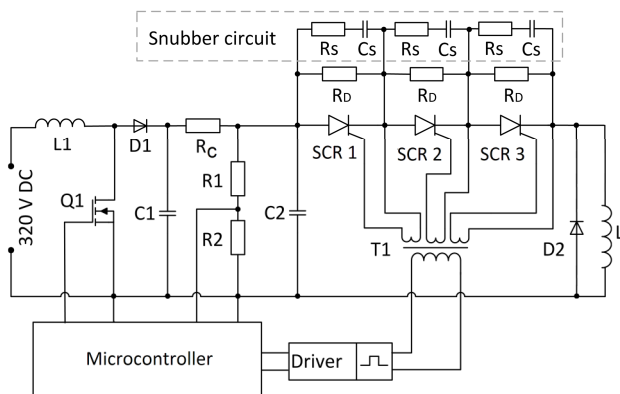

Fig. 3. Simplified scheme of the pulsed magnetic field generator.

Three high power fast thyristors are connected in series in order to expand the maximum voltage of the facility, which is 1.8 kV. The discharge capacitor C2 value has been chosen to be 0.3  $\mu\text{F}$ . The overall control of the magnetic field

generator including the feedback of the boost converter has been implemented using microcontroller. The microcontroller regulates the duty cycle of the pulses to open high frequency MOSFET Q1, which allows accurate control of the output voltage. Crowbar diode D2 has been also implemented in the circuit, which provides effective method of protecting the circuitry from being damaged by over-voltage scenarios. The snubber circuit is also used to insure properly and save operation of thyristor switches. The maximum repetitive frequency of the pulses is 40 Hz and can be varied in the range of 0–40 Hz when the peak current is in the range of 0–550 A. The current and the repetitive frequency of the pulses are limited in order to minimize the overheating of the microcoil that is used as a load. The repetitive frequency and the number of pulses are controlled by the microcontroller circuit, which controls the driver of the thyristors.

The magnetic field generator has been assembled into a compact anodized aluminium case. The prototype facility is portable having dimensions of 60 cm  $\times$  12 cm  $\times$  40 cm. Developed generator is compatible with common used laboratory equipment, can be used separately or together with other bioelectronic, measuring, computing or data processing facilities. The pulsed power generator is shown in Fig. 4.



Fig. 4. Developed compact pulsed power generator.

During experimentation the tested biological sample is put inside the cuvette integrated in the pulsed coil. Therefore, additional plastic coating was implemented inside the solenoid to ensure contactless treatment and form a cuvette. The coil has been attached to an epoxy glass 1 cm  $\times$  3.5 cm plate with electrode pads that were securely connected to the pulsed power generator by application of screws. The schematic of the fabricated chip with magnetic field cuvette is shown in Fig. 5.

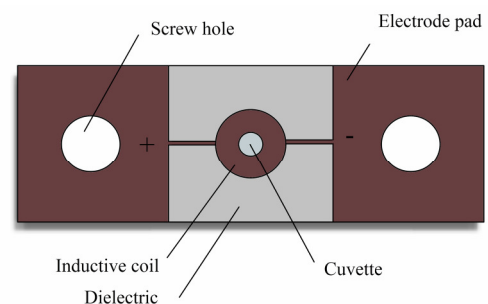

Fig. 5. Schematic of the fabricated chip with magnetic field cuvette.

Implementation of such chip structure allows comfortable delivery and acquisition of samples in and out of the cuvette.

Also if needed the designed chip can be easily disconnected from the facility and examined under the microscope.

## V. EXPERIMENTAL RESULTS

Developed pulsed magnetic field generator was tested at VGTU High Magnetic Field Laboratory. The pulse waveform of the pulsed magnetic field generator is shown in Fig. 6.

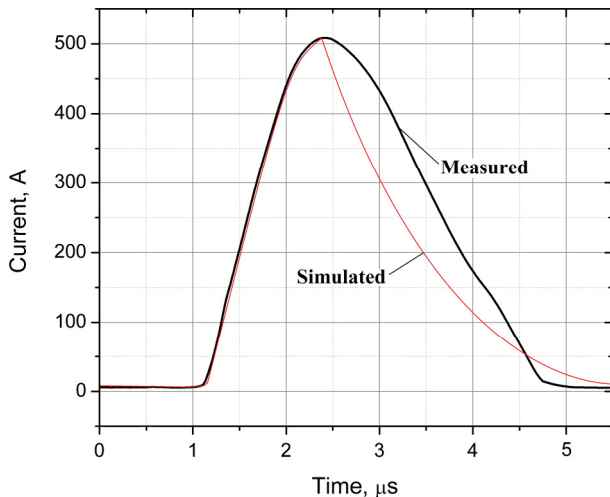

Fig. 6. Current waveform of the pulsed magnetic field generator.

The acquired pulse is unipolar with maximum current value of 510 A. The rise time of the pulse is in the range of 1.2  $\mu\text{s}$  when the 1.7  $\mu\text{H}$  load coil is used. The overall pulse width is 3–4  $\mu\text{s}$ . These values are in acceptable agreement with the simulated parameters. In order to test the magnetic field facility immortalized line of the human lymphocyte cells was treated by pulsed magnetic field. The human cells during pulsed magnetic field treatment and the treatment efficiency based on the number of pulses are shown in Fig. 7.

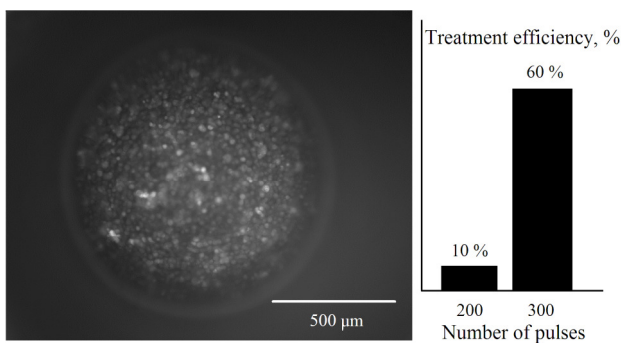

Fig. 7. Human cells during pulsed magnetic field treatment and the treatment efficiency based on the number of pulses.

The samples were treated by pulsed magnetic field and later biological analysis with further incubation for several days has been performed. The ethidium bromide staining (EtBr) was used as a fluorescent dye. During magnetoporation nanoscale pores were created in the cell membranes and the dye was transported into the cell. By quantification of the amount of fluorescent and non-fluorescent cells the treatment efficiency could be estimated. According to the experimental data the human cells showed positive results on the occurrence of cell membrane permeabilization. The treatment of lymphocyte cells to 200

and 300 magnetic field pulses showed treatment efficiency of 10 % and 60 %, respectively.

## VI. CONCLUSIONS

The high power pulsed magnetic field generator for applications in bioelectronics has been developed. The generator is capable of generation magnetic field pulses up to 5 T with rise time in microsecond range and operating under non-repetitive and repetitive modes up to 40 Hz. The FEM modelling of maximal value of pulsed magnetic field and field distribution has been carried out. Simulation results are in acceptable compliance with the experimental results. The proposed magnetic field treatment cuvette's structure does not only ensure equal treatment of the biological samples, but also makes the treatment non-contact. The pulse shape is undependable on the cell medium parameters, which is highly important in experiments in the area of cell membrane permeabilization. In order to test the facility human lymphocyte cells were treated by pulsed magnetic field. During experiment a clear treatment efficiency change based on the treatment intensity was acquired. The proposed magnetic field facility could be applied in the field of bioelectronics to investigate magnetoporation effects; however all of the factors influencing the treatment should be investigated in future works. The proposed pulsed magnetic field generator is compatible with commonly used experimental equipment, can also be used separately or together with other measuring and data processing facilities. Further improvement of the pulsed generator can be implemented by application of planar coils and fast high power MOSFET switches, which would allow creating a pulsed magnetic field generator capable of generation up to 10–15 T in sub-microsecond range.

## REFERENCES

- [1] A. Ivorra, "Tissue electroporation as a bioelectric phenomenon: Basic concepts", *Irreversible Electroporation, Series in Biomedical Engineering*, Springer Berlin Heidelberg, pp. 23–61, 2010. [Online]. Available: <http://dx.doi.org/10.1007/978-3-642-05420-42>
- [2] S. B. Dev, D. P. Rabussay, G. Widera, G. A. Hofmann, "Medical applications of electroporation", *IEEE Trans. Plasma Science*, vol. 28, no. 1, pp. 206–223, 2000. [Online]. Available: <http://dx.doi.org/10.1109/27.842905>
- [3] C. B. Arena, M. B. Sano, M. N. Rylander, R. V. Davalos, "Theoretical considerations of tissue electroporation with high-frequency bipolar pulses", *IEEE Trans. Biomedical Engineering*, vol. 58, no. 5, pp. 1474–1482, 2011. [Online]. Available: <http://dx.doi.org/10.1109/TBME.2010.2102021>
- [4] T. Kotnik, P. Kramar, G. Pucihar, D. Miklavcic, M. Tarek, "Cell membrane electroporation- part 1: The phenomenon", *IEEE Electrical Insulation Magazine*, vol. 28, no. 5, pp. 14–23, 2012. [Online]. Available: <http://dx.doi.org/10.1109/MEI.2012.6268438>
- [5] A. Grainys, V. Novickij, J. Novickij, A. Stirke, V. Kaseta, "High power facilities for electroporation of biological cells in pulsed magnetic fields", in *Proc. IEEE 19th Int. Conf. Microwave Radar and Wireless Communications (MIKON)*, 2012, vol. 2, pp. 508–511.
- [6] A. Butterwick, A. Vankov, P. Huie, Y. Freyvert, D. Palanker, "Tissue damage by pulsed electrical stimulation", *IEEE Trans. Biomedical Engineering*, vol. 54, no. 12, pp. 2261–2267, 2007. [Online]. Available: <http://dx.doi.org/10.1109/TBME.2007.908310>
- [7] F. Herlach, N. Miura, *High magnetic fields: science and technology: magnet technology and experimental techniques*. World Scientific Publishing Company, 2003, pp. 204–205.
- [8] S. Bartkevicius, J. Novickij "The investigation of thermodynamic processes in pulsed coils with crowbar circuit", *Elektronika ir Elektrotechnika (Electronics and Electrical Engineering)*, no. 4, pp. 99–102, 2010.