

Multi-technological Transmission Platform for a Wide-area Sensor Network

M. Habrych¹, K. Staniec², K. Rutecki², B. Miedzinski¹

¹Faculty of Electrical Engineering, Wrocław University of Technology,
Wyb. Wyspińskiego 27, 50-370 Wrocław, Poland

²Faculty of Electronics, Wrocław University of Technology,
Wyb. Wyspińskiego 27, 50-370 Wrocław, Poland, phone: +48 71 320 34 34
marcin.habrych@pwr.wroc.pl

Abstract—The article presents an idea of building a wide-area sensor network for monitoring the environmental state. The network combines different technologies for data acquisition and is heterogenic in that it is suited to use different data transmission technologies. A distinguishing feature, making this network different from its existing counterparts, is its easy expansion by adding new sensor types, as well as its scalability and functional universality.

Index Terms—Condition monitoring, wide area networks, wireless communication, wireless sensor networks.

I. INTRODUCTION

The air state monitoring has been gaining on importance recently, particularly in densely populated clusters and in the vicinity of industrial plants [[1]]–[3].

It may include: air pollution by gases and dust, electromagnetic field level in a broad spectrum, contamination of water and soil, noise level, the amount and composition of sewage, the amount and characteristic of accumulated precipitations and various other elements of live nature, according to given requirements. The registration of the measured parameters may take place by both manual and/or automatic means [4], [5].

Increasingly important is the air state indoors – in offices or production halls as a correlation has been found to exist between the workers' respiratory comfort and their working effectiveness or production quality.

Wrocław University of Technology is involved in a project aiming at creating a modern, yet inexpensive, and most of all – scalable system for environmental monitoring, capable of adopting sensors of arbitrary physical phenomena and chemical compounds.

II. A GENERAL SYSTEM STRUCTURE

The general architecture of the system for acquiring data

Manuscript received March 19, 2012; accepted May 24, 2012.

This paper has been written as a result of realization of the project entitled: "Detectors and sensors for measuring factors hazardous to environment – modeling and monitoring of threats".

The project financed by the European Union via the European Regional Development Fund and the Polish state budget, within the framework of the Operational Programme Innovative Economy 2007–2013.

The contract for refinancing No. POIG.01.03.01-02-002/08-00.

from sensors measuring environmental parameters, has been shown in Fig. 1.

The core of the system, scattered over a vast area, is the GSM/GPRS communication, hence the use of Wavecom Q2687 wireless modules which possess a considerable number of communication interfaces. The data measured by sensors, after initial processing by the Format Adaptation Module (FAM) are first transmitted by the ZigBee/RS422 network, so called a local segment or a Wireless Sensor Network (WSN) [6]. Next, the data are transmitted in the GSM/UMTS network (so called a core segment) to the Data Acquisition Module (DAM). The choice of GSM technology to serve as a core platform is a result of meticulous analysis of communication technologies available nowadays.

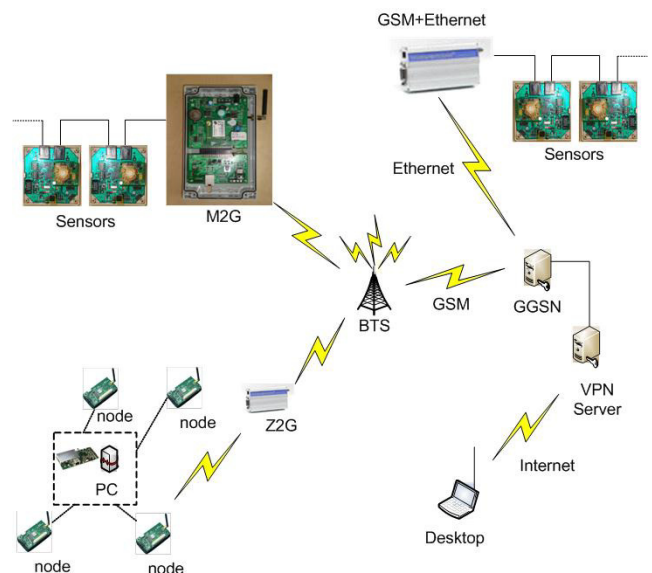

Fig. 1. A general structure of the data acquisition system collecting data from environmental sensors.

The following criteria were established:

- 1) *National coverage;*
- 2) *Portability (understood as a possibility to deploy a given sensor module in an arbitrary region with no further efforts associated with installing any infrastructure to gain access to a transportation core network);*
- 3) *A controlled (best if licensed) frequency band;*

- 4) Reliability and security;
- 5) Scalability.

The first two criteria are satisfied by GSM as well as WiMAX (World-Wide Microwave Access) or WiFi (Wireless Fidelity). However, the latter technology will only be limited to selected points (hot spots) where access points have been installed. This limits the range mainly to buildings or city market squares. More scarcely populated areas will be viewed as “white patches”. WiMAX, in turn, despite a considerable momentum in many countries, seems to be – in the long run – a losing side in the technological race with cellular systems of the 3rd (e.g. Universal Mobile Telecommunication System or UMTS) and especially the 4th generation systems (e.g. Long-Term Evolution or LTE). There are multiple reason of such – so unfavourable to WiMAX – forecasts, which now be enumerated. There already exists a large quantity of equipment cooperating with the 3G and 4G systems (as for WiMAX it has encountered great difficulties paving its way to the laptop and cell phone producers). The cellular networks are favoured by governments also with respect to the capital invested in their development as priority targets of economy. As regards technical performance, the throughput offered by WiMAX has also ceased to be competitive to UMTS or LTE. These observations make GSM and its further releases such as UMTS or LTE, a natural candidate for the core segment of the sensor network. As for the throughput, as regards sensors with low requirements for data transmission speeds, the GPRS and EDGE modes offer 56 and 160 kb/s, respectively. For sensors with greater needs in this respect, so called HSPA+ and HSPA+DC modes offer throughputs up to 42 Mb/s. In LTE, currently achievable data rates peak at 80 Mb/s (theoretically, for selected family of terminals, even up to 326 Mb/s). Since GSM services are now offered by usually a few major operators (and several virtual ones), service quality and its reliability is high. It is advisable to have an agreement – for the core segment of the sensor network – with an operator, assuring services within a closed Access Point Name (APN). This is a virtual space of the operator’s resources assigned solely to the end-user’s SIM cards, as if in a private network, which guarantees the first-order security mechanism, i.e. the physical protection of the transmission network. Within the APN, only SIM cards pre-registered by the user will be served based on their International Mobile Subscriber’s Identity (IMSI) numbers.

The scalability is understood in two ways: by the ease of adjusting the transmission speed (by suiting the technology to the needs of a particular sensor and – what follows – the transmission costs) and by the quantitative scalability of modules in the WSN network. The current GSM/UMTS/LTE capacity offers the scalability feature of up to a few million terminals or more.

III. THE LOCAL SEGMENT – ZIGBEE

The concentrator model (i.e. a module responsible for receiving data from a local ZigBee network for further transmission to DAM) is shown in Fig. 2. The concentrator (Z2G – Zigbee2GSM) consists of two main components:

- 1) A programmable GPRS/EDGE SierraWireless Q268x terminal;
- 2) A programmable Atmel (formerly Meschnetics) ZigBee transceiver.

The Q268x terminal has been chosen since it is the only GPRS/EDGE model available in the market, to be programmed in C language. It offers access to: the internal ARM9 processor, the Real-Time Operating System (RTOS), the TCP/IP stack and a broad scope of Internet functions. The compiled program is run as coexisting component of the modem firmware, which eliminates the use of an additional processor and an operating system.

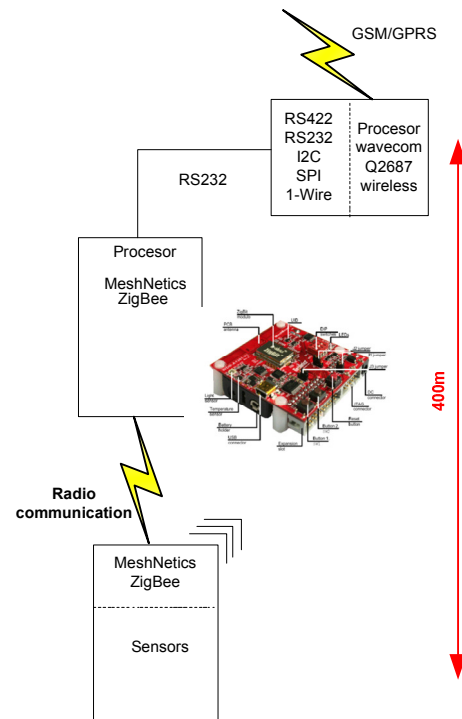

Fig. 2. A model of a local ZigBee network concentrator.

The ZigBee Transceiver, in turn, has been chosen for a pragmatic reason. A ZigBee module was sought, which firmware could be easily replaced with one’s own program. Out of a myriad of available solutions, only that model offered this desired feature. Moreover, the Atmel’s radio modules are characterized by the highest sensitivity which is a vital parameter in the trade-off between the range and the energy consumption. ZigBee network is controlled by PC (PAN Coordinator).

The local segment in the ZigBee wireless technology is therefore characterized by a substantial elasticity regarding the physical deployment of sensors in space. This virtue, combined with the automatic network self-organization ability, allows one to build on-demand networks, e.g. in case of critical failures, catastrophes or during *ad-hoc* environmental measurements.

IV. THE CORE SEGMENT GSM – MODBUS/RS422 (+ ETHERNET)

Starting works on a WSN, sensors may initially present themselves as “black boxes”. Only in the course of research, some sensors revealed a very mischievous feature. Namely,

as far as sensors for measuring basic air factors (such as temperature, humidity or pressure) are not very energy-consuming, the chemical sensors are. It is strongly associated with the principle of measurement they implement. They are catalytic sensors where the measurement is done by heating a sample (or even its incineration) to produce the target gas to be measured, as a product of such a reaction. Now, the heater is the real energy scavenger in this set-up. For ZigBee-based networks, solar panels may sometimes be a solution of choice [7]. The application of the ZigBee technology in combination with the battery power supply (most often the case) means a short life time of the sensor module. Hence, another variation of the concentrator has been designed (M2G – Modbus2GSM), to which sensors are connected by RS422 or CAN network, using ModBus RTU as a transmission protocol. In this way, scalability in the local segment has been achieved allowing up to 254 sensor modules connected to a single concentrator. Additionally, the same cable is shared for both energy supply and data transmission. The sensor module, is equipped with its own ARM Cortex-M3 microprocessor, two interfaces (in compliance with the ModBus standard) and several gas sensors (depending on needs). A block diagram of such a concentrator is presented in Fig. 3.

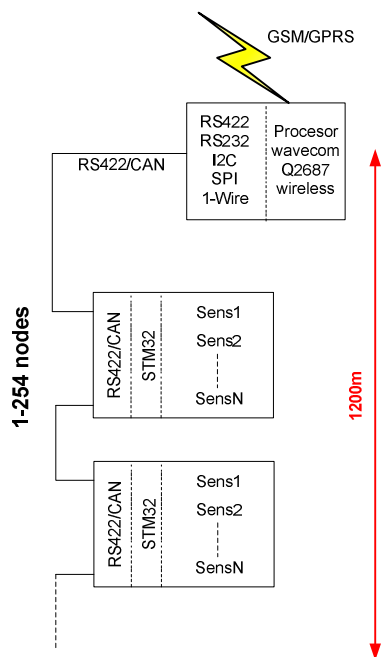

Fig. 3. A ModBus network concentrator module.

The sensor module construction comprises two circuits (Printed Circuit Boards):

- 1) a Format Adaptation Module FAM (Fig. 4, (a-c));
- 2) A microprocessor module (Fig. 4, d).

The microprocessor module, universal for all sensor nodes, is responsible for the ModBus operation. It performs basic mathematical calculations and, by its Analog-to-Digital Digital-to-Analog converters (ADC and DAC, respectively), samples the signal processed by the FAM module. The FAM module (consisting of amplifiers, filters, reference voltage and/or current sources etc.) in turn, is responsible for the initial analog processing of the sensor signal in accordance with its application note.

Such a construction allows to have only one microprocessor module and as many FAM modules as there are different sensor types used. The modular architecture allows one to scale the platform practically infinitely by adding new sensors which – after their installation on an appropriate FAM module – can then be easily integrated with the microprocessor module (an example of a stack-up mounting is shown in Fig. 5).

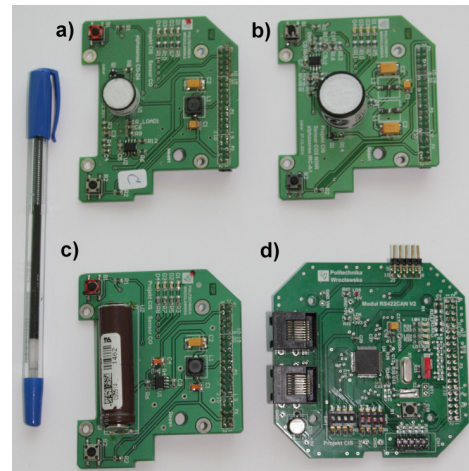

Fig. 4. A top view of: a-c) examples of FAM module with sensors; d) a microprocessor module.



Fig. 5. A view of a FAM module integrated with a microprocessor module.

Complementary to the two former concentrator modules is a version equipped with an additional Ethernet port. Such an implementation offers a redundant data transmission technology on the access segment level. The concentrator may operate both in the Ethernet and GSM networks simultaneously or separately. The Ethernet interface is integrated into the Q268x modem firmware as another medium to be considered in the sensor network. Other concentrator features on the higher TCP/IP layers (from the link layer upwards), including the software and the protocol, have been preserved.

V. CORE SEGMENT – A FOCUS ON THE PROTOCOL

The measured data gathered by the concentrator (either ZigBee network or Modbus) are queued up in it, time stamped and (according the schedule) sent to DAM, using HTTPS as a transmission protocol, which keeps the measured data confidential through the ciphered transmission. Since a two-side TLS/SSL authentication has been used, the concentrator has a certainty of being connected to a proper server. On the server side, it has a certainty that the concentrator is eligible for connecting, which is guaranteed by X509 certificates. In this way two more critical parameters have been achieved – the integrity

and non-repudiation. The concentrators using the Network Time Protocol (NTP), are able to synchronize their own real-time clocks with the atomic time server. Therefore, the time synchronization of the measured samples throughout the network, has been eliminated, regardless of the geographical range of the installation.

VI. CORE SEGMENT – A FOCUS ON DAM

The last element of WSN is the DAM module. It is a critical component responsible for gathering, storing and making accessible the measured data for further analysis. This makes the reliability an indispensable feature. MySQL (Cluster Edition) has been used in the project. Each concentrator (its number being unlimited by any means) allows one to connect up to 254 sensor modules, out of which each may have up to $2^{16}-1$ 16-bit registers for storing the measured results, configuration and statistical parameters, physical constants etc. Moreover, from the database level, any parameter of any sensor can be modified. This is due to the accepted policy for identifying each sensor with a unique serial number, which also simplifies WSN. The concentrator does not store the local network topography. Instead, after logging into DAM, as a part of the session set-up, it obtains a set of configuration parameters in return. In addition, after each data transmission session, in the acknowledgement-request packet sent to DAM, the concentrator may obtain the modified parameters of both sensors and the network itself. Such modifications may concern, for example, the updated sensor sensitivity or the switch-off of a failed module in the local network.

VII. ELECTROMAGNETIC COMPATIBILITY (EMC) ISSUES IN THE CORE SEGMENT (GSM/GPRS)

As has been said, the Modbus-over-GPRS concentrator which is the basic element of the wireless sensor network. Although the only desired radiating element in the device is the radio module, one should also expect spurious radiations originating from electronic circuitry joining separate sensors (via Modbus, as shown in Fig. 3) and from paths on printed circuit boards. Moreover, these undesired parasitic transmissions may also arise from harmonics generated on the device nonlinearities, whose combined effect may create a real threat by emitting interference in frequency bands other than desired.

For this reason, the concentrator emissive properties should be carried out for the whole device (including all sensors and their respective Modbus interconnections) since the combined radiation pattern may differ from that obtained from just the radio module. Fig. 6 shows the measurement set-up inside an anechoic chamber (located at the Institute of Telecommunications, Teleinformatics and Acoustics at Wroclaw University of Technology) where the concentrator radiation pattern was measured for all angles at two positions: horizontal and vertical. The device was placed on a rotational basis and its radiated power was measured at 36 angular increments of 10° each. The received power was measured with a Zondas 04792 (P6-23A) antenna of a well-known gain. Results of investigations are shown in Fig. 7. At the first sight it can be seen that there occur clear nulls in the

radiation pattern. The other notable observation is that the device attenuates signals transmitted at higher frequencies DCS1800 band (represented by 1765 MHz carrier) considerably more than those in the lower bands (GSM900 represented by 912 MHz carrier), although the pre-programmed settings were identical, i.e. the output power was in either case set to the maximum.

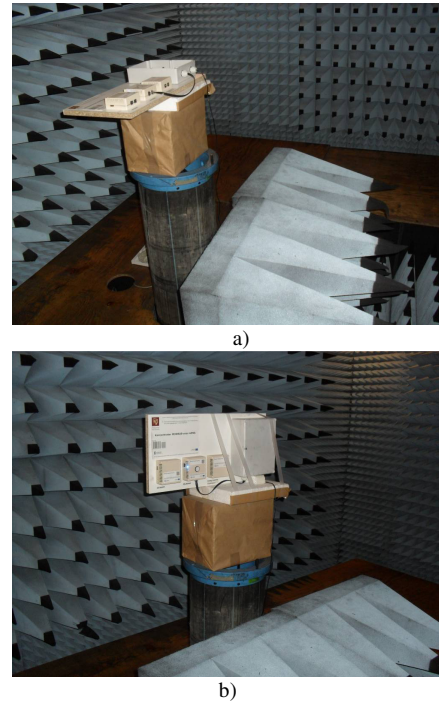

Fig. 6. The concentrator orientation during ARP measurements in the horizontal (upper) and vertical (lower) position.

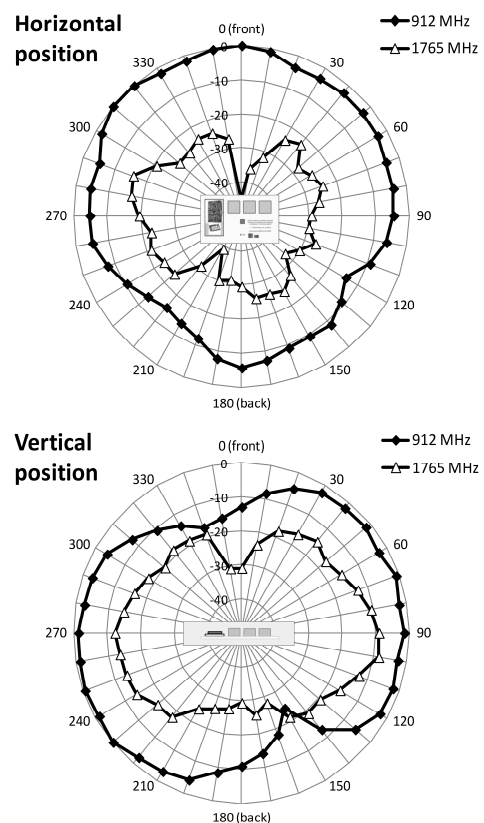

Fig. 7. The concentrator radiation pattern measurement for two different frequency bands: DCS1800 and GSM900.

In many cases interference is caused by imperfectly constructed physical devices (modems in the core segments) which produce radiation in unwanted frequency bands thus interfering with other radio systems residing there. Since the core segment consists of equipment operating in licensed cellular bands, it is treated as a regular cell phone and is subjected to the same co-channel interference mechanisms. Interference to other in-band GSM terminals and base stations (BTS) is not an issue since the core system by itself prevent transmission on the same frequencies and time slots within a given cell. Therefore, the authors rather focused on interference caused by the concentrator to other cellular system users and BTS's that operate in a different frequency band, as shown in Fig. 8.

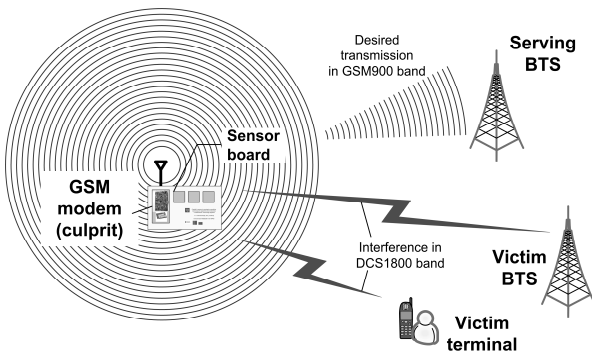

Fig. 8. Interference caused by the GSM modem (concentrator) in GSM900 band to a terminal and a BTS in DCS1800 band.

One will begin with showing the radiated power vs. frequency from the GSM modem. For high output power settings, in many commercially available modems, one may expect that due to the amplifier non-linear characteristic a relatively strong 1st-harmonic signal (n decibels weaker than the desired signal) will be generated as in Fig. 9.

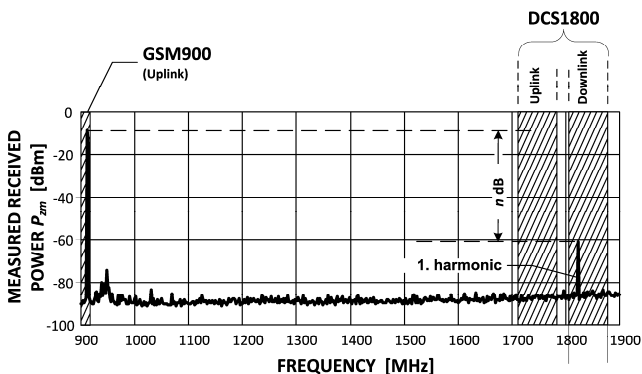

Fig. 9. Radiated emission from the core GSM modem (core segment): the wanted signal and the undesirable 1st harmonic.

Unfortunately, this unwanted radiation – though derived from a 900 MHz band operation (i.e. GSM900) – falls into another GSM band. Uplink (UL) and downlink (DL) terms mean transmission from the terminal to BTS and vice versa, respectively. In other words, both – terminals and BTS's – may be victims to interference from a GSM modem (the concentrator) transmitting sensor data. The strength of this disturbance is naturally mitigated by attenuating factors such as vegetation or buildings, but for the purpose of EMC investigations, the worst-case scenario should be considered in which free-space (i.e. an unobstructed line of sight, LOS)

propagation conditions are present.

Based on the measured Equivalent Isotropic Radiated Power (EIRP) one can fairly easily calculate the safe operational distance d_{safe} required between the core segment GSM concentrator and different types of base stations or terminals. All BTS and terminal parameters needed for respective calculations can be obtained in the GSM specification [8]. The most crucial information found there regards the maximum acceptable ratio between the useful (desired) received signal power P_{use} to the interfering signal I_{int} , also called a Signal-to-Interference Ratio (SIR). According to [8] it is defined as in Table I.

TABLE I. DEFINITIONS OF THE REQUIRED SIR VALUES FOR MOBILE STATIONS (MS) AND BASE STATIONS (BTS) IN GSM (BASED ON [8]).

Distance from the carrier	SIR = P_{use}/I_c or (P_{min}/I_{max})*
Co-channel, f_c	9 dB
Adjacent channel (f_c-200 kHz)	-9 dB
Adjacent channel (f_c-400 kHz)	-41 dB
Adjacent channel (f_c-600 kHz)	-49 dB
* P_{min} – minimum desired signal power on the receiver input I_{max} – maximum interfering signal power on the receiver input	

Now, assuming free-space propagation, the obtained values of the safe distance can be found, knowing the sensitivity power P_{sens} of the interfered devices which should be treated separately for Mobile Stations (MS) and Base Stations. In the former case one should accept the most pessimistic case of $P_{sens}=-104$ dBm (which gives the safe distance $d_{safe}\approx 27$ m), in the latter, P_{sens} is given in tab. 2 together with the calculated values of d_{safe} .

In an example the authors have provided results of a real-life computations performed on GSM concentrators used the project titled “Detectors and sensors for measuring factors hazardous to environment – modelling and monitoring of threats”. The power of the 1-st harmonic (i.e. the unwanted radiation) in this case was measured to be -60.6 dBm, i.e. it was less by $n=51.7$ dB than the desired transmission EIRP (refer to Fig. 7 for details). With these values in mind and for the sensitivity power P_{sens} as in the above paragraph, safe distances from different types of base stations have been calculated and placed in Table II.

TABLE II. DEFINITIONS OF THE REQUIRED SIR VALUES FOR BASE STATIONS (BTS) IN GSM (BASED ON [8]).

BTS type	P_{sens} [dBm]	Safe distance d_{safe}
Normal BTS	-104	265,71 m
Micro BTS M1	-102	167,65 m
Micro BTS M2	-97	53,02 m
Micro BTS M3	-92	16,77 m
Pico BTS P1	-95	33,45 m

VIII. CONCLUSIONS

Although currently there exist multiple systems for environmental monitoring, the system proposed and implemented by the authors has a few features that distinguish it from the existing systems:

- scalability – a possibility to connect a practically infinite number of concentrators with sensor modules,

- universality – a possibility to connect any arbitrary sensor after its adaptation and connection to FAM module designed during the project,
- a multi-technology platform of collecting measurement data to the concentrator (i.e. radio – ZigBee/RS422 or CAN/Ethernet).

REFERENCES

- [1] B. Miedziński, K. Rutecki, M. Habrych, “Autonomous Monitoring System of Environment Conditions”, *Elektronika ir Elektrotechnika (Electronics and Electrical Engineering)*, no. 5, pp. 63–66, 2010.
- [2] A. Severdaks, G. Supols, M. Greitans, L. Selavo, “Wireless Sensor Network for Distributed Measurement of Electrical Field”, *Elektronika ir Elektrotechnika (Electronics and Electrical Engineering)*, no. 1, pp. 7–10, 2011.
- [3] B. Wang, K. Chaing Chua, V. Srinivasan, W. Wang, “Information Coverage in Randomly Deployed Wireless Sensor Networks”, *IEEE Transactions on Wireless Communications*, vol. 6, no. 8, pp. 2994–3004, – 2007.
- [4] E. Lee, S. Partk, J. Lee, S. Oh, S.-Ha Kim, “Novel Service Protocol for Supporting Remote and Mobile Users in Wireless Sensor Networks with Multiple Static Sinks”, *Wireless Networks*, vol. 17, no. 4, pp. 861–875, 2011. [Online]. Available: <http://dx.doi.org/10.1007/s11276-011-0320-4>
- [5] D. J. Cook, S. K. Das, *Smart Environments: Technologies, Protocols and Applications Wireless sensor networks*. USA: John Wiley, 2004. [Online]. Available: <http://dx.doi.org/10.1002/047168659X>
- [6] *Wireless Medium Access Control (MAC) and Physical layer (PHY) Specification for Low-Rate Wireless Personal Area Networks (WPANs)*, IEEE Standard 802.15.4-2006, Part 15.4.
- [7] D. Vasarevicius, R. Martavicius, “Solar Irradiance Model for Solar Electric Panels and Solar Thermal Collectors in Lithuania”, *Elektronika ir Elektrotechnika (Electronics and Electrical Engineering)*, no. 2, pp. 3–6, 2011.
- [8] *Digital cellular telecommunications system (Phase 2+); Radio transmission and reception (GSM 05.05 version 8.5.1 Release 1999)*, ETSI EN 300 910 V8.5.1 (2000-11).