

Immunity of Residual Current Devices to the Impulse Leakage Current in Circuits with Variable Speed Drives

S. Czapp¹, K. Borowski¹

¹Gdansk University of Technology,
Narutowicza 11/12 St., 80-233, Gdansk, Poland
s.czapp@ely.pg.gda.pl

Abstract—This paper concerns reliability of supply in variable speed drive circuits with residual current devices. During normal operation of these circuits high value of leakage current causes unwanted tripping of residual current devices. Immunity of residual current devices to the impulse leakage current should be evaluated. The system for testing of residual current devices and results of the test are presented.

Index Terms—Power installations, reliability of supply, residual current devices, variable speed drives.

I. INTRODUCTION

Residual current devices (RCDs) ensure automatic disconnection of supply in low voltage systems especially if the impedance of the fault limits the current to a value that is below the overcurrent protection threshold. In special cases, e.g. for areas with a low-impedance contact of persons with earth potential, additional protection is required [1], [2]. Then the use of residual current devices with a rated residual operating current not exceeding 30 mA ($I_{\Delta n} \leq 30$ mA) is appropriate. Such residual current devices prevent serious injury in case of direct contact [3].

Residual current devices may be classified upon their ability of detection of a determined current waveform and time-delay operation.

RCDs are recognized by their ability of detection of a determined current waveform as [4], [5]:

- AC – for residual sinusoidal alternating currents (50/60 Hz),
- A – for residual sinusoidal alternating currents (50/60 Hz) and pulsating direct residual current,
- B – for residual sinusoidal alternating currents up to 1000 Hz, pulsating direct residual current and smooth direct residual current.

By the time-delay operation, there are three types of residual current devices:

- general purpose RCD, without intentional time-delay, without special symbol,
- short time-delayed RCD (G-type), with a minimum non-actuating time of 10 ms,

- time-delayed RCD (S-type), with a minimum non-actuating time of 40 ms, to provide discrimination with downstream general purpose or G-type RCD.

In the variable speed drive circuits transient and steady-state leakage current may flow. This current has impulse spectrum [6], [7] with frequency which depends on the Pulse Width Modulation (PWM). Peak value of a steady state current may reach a few amperes. Leakage current should not cause the unwanted tripping of RCDs. Leakage current in circuit with variable speed drives depends on the capacitances to earth (Fig. 1).

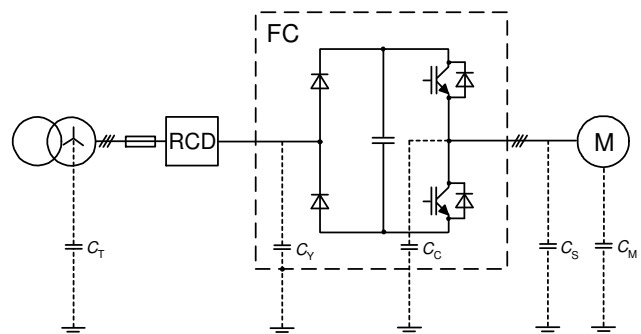

Fig. 1. Capacitances to earth in circuit with variable speed drive – general diagram, RCD – residual current device, FC – frequency converter, M – motor (for “C” see text below).

The following capacitances are distinguished in circuit with variable speed drives [8], [9]:

- C_T – capacitance between the line supply and earth (short-circuited if the neutral point is earthed),
- C_Y – interference suppression capacitance at the drive input,
- C_C – capacitance of the IGBT components between conductors and enclosure connected to earth,
- C_S – capacitance between the output conductors and earth (depending on the length of the cables and their type – shielded, unshielded),
- C_M – capacitance between the motor windings and earth (depending on the motor construction and rating).

In the earthed low voltage system the highest value of leakage current components (I_1 , I_2) circulate across the capacitances as in Fig. 2.

In such circuit it is important to select proper RCD in order to avoid its unwanted tripping during the absence of

earth fault or direct contact.

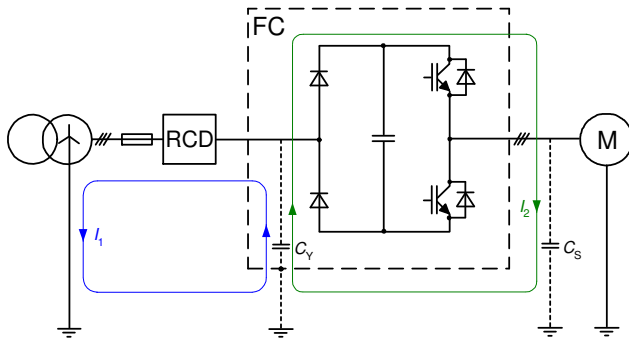

Fig. 2. Circulation of high frequency leakage currents (I_1 , I_2) in circuit with variable speed drive – earthed low voltage system.

II. LEAKAGE CURRENT IN CIRCUITS WITH VARIABLE SPEED DRIVES

In the selected circuits with variable speed drives a measurement of leakage current using digital oscilloscope was performed. The measurement was performed according to the structure presented in Fig. 3.

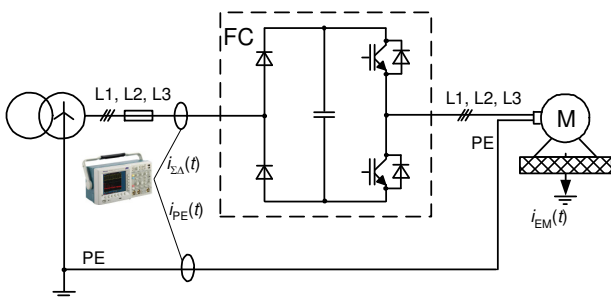

Fig. 3. Structure of the analyzed variable speed drive circuit; important currents: $i_{\Sigma\Delta}(t)$ – total leakage current (measured), $i_{PE}(t)$ – current in protective conductor (measured), $i_{EM}(t)$ – current flowing through the motor construction (not measured).

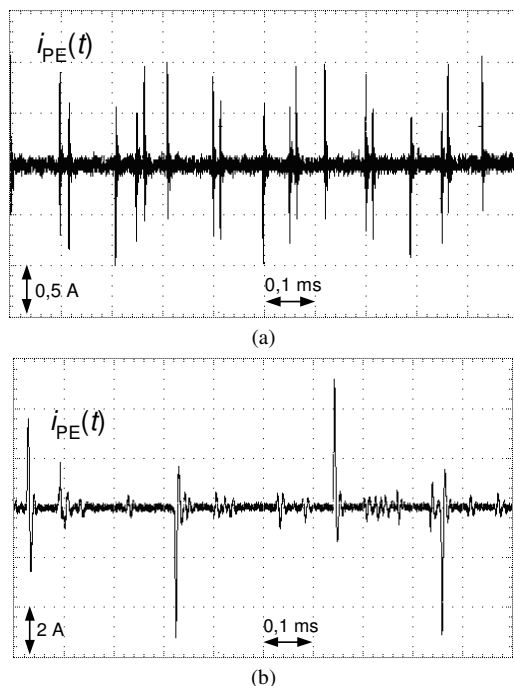

Fig. 4. Current in the protective conductor $i_{PE}(t)$: a) 4 kW drive, b) 12 kW drive.

The current in the protective conductor $i_{PE}(t)$ was measured first (Fig. 4). In the 12 kW drive, the current in the

protective conductor $i_{PE}(t)$ and the total leakage current $i_{\Sigma\Delta}(t)$ were measured simultaneously (Fig. 5).

Peak value of the current in a protective conductor $i_{PE}(t)$ of the 120 kW drive (Fig. 4b) reaches a few amperes. Such value of leakage current may cause nuisance tripping of protective devices – residual current devices. Very important is the conclusion that may be drawn from the waveforms presented in Fig. 5. The analysis of these two waveforms indicates that total leakage current $i_{\Sigma\Delta}(t) \approx i_{PE}(t) + i_{EM}(t)$ is twice as strong as the current in the protective conductor $i_{PE}(t)$.

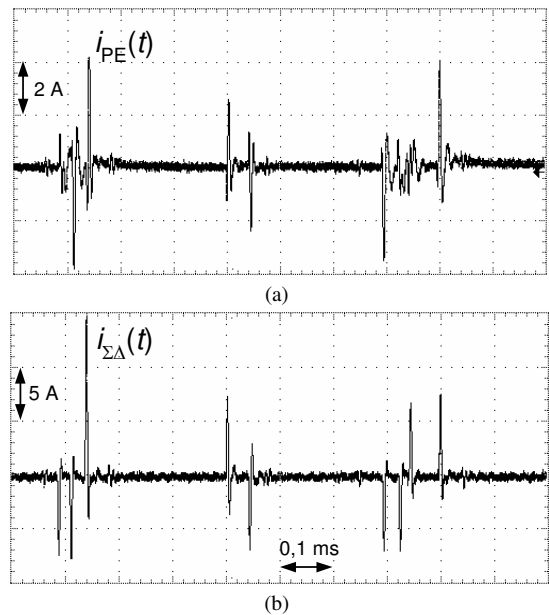

Fig. 5. Currents in the circuit with frequency converter (12 kW drive): a) current in the protective conductor $i_{PE}(t)$, b) total leakage current $i_{\Sigma\Delta}(t)$ (including current flowing through the motor construction).

The total leakage current $i_{\Sigma\Delta}(t)$ is a representative current – not the current in protective conductor, which is measured in practice. The total leakage current should be taken into consideration when residual current devices are selected.

The above presented leakage currents are the basis for designing a laboratory system for the leakage current generating.

III. LABORATORY STAND AND TEST

It is very important for reliability of supply to select a residual current device which is immune to the natural leakage current in a circuit. In order to evaluate real immunity of residual current devices a laboratory test was performed. The most popular, general purpose type AC and type A 30 mA RCDs were tested. The aim of the test was to find peak value of leakage current which causes tripping of the mentioned residual current devices.

In order to perform laboratory test a laboratory stand comprising programmable power supply, PC computer and oscilloscope was prepared [10]. The power supply was programmed using LabVIEW environment. Figure 6(a) presents a front panel of the laboratory instrument and Fig. 6(b) presents a waveform shape of the testing impulse current. In real circuits the leakage current is unsymmetrical so during the test the impulse current was also unsymmetrical.

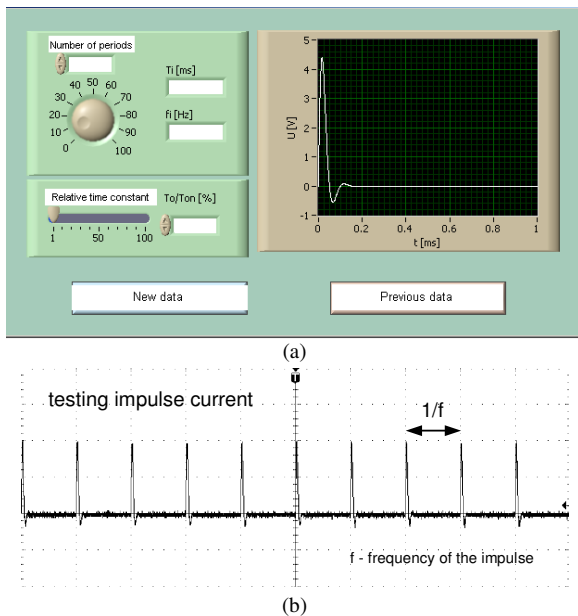

Fig. 6. Front panel of the LabVIEW programmed electronic instrument (a) and oscillogram of the testing impulse current (b).

The test was performed for five values of the impulse frequency: 100 Hz, 200 Hz, 300 Hz, 500 Hz and 1000 Hz. Peak value of the testing current was established for 0,1; 0,5; 1 and 3 amperes respectively. Tripping or not tripping of the tested RCDs, for particular frequency and peak value of the current, was recorded. The laboratory stand structure for RCD testing is presented in Fig. 7.

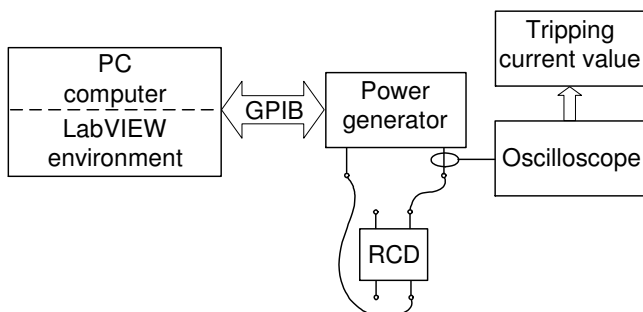

Fig. 7. The laboratory stand structure; RCD – tested residual current device.

Results of the test for selected general purpose (no time-delayed) residual current devices RCD1, RCD2, RCD3 and RCD4 are presented below (Fig. 8–Fig. 11). The columns in the appropriate place in Fig. 8–Fig. 11 mean that the tested RCD tripped out.

RCD1 tripped out for all forced frequencies if peak value of the testing current was equal to 1 or 3 amperes (Fig. 8(a)). For the testing current of 0,5 ampere tripping of RCD1 was recorded only for the following frequencies: 100 Hz, 300 Hz and 500 Hz. If the testing current was equal to 0,1 ampere there was no reaction of RCD1 in the whole frequency range.

The above presented measurement results mean that it is highly probable that RCD1 is not immune to the impulse leakage current in circuits with variable speed drives.

Slightly higher immunity to the testing current represents RCD2 (Fig. 9(a)). The higher the impulse current frequency the higher value of peak current is necessary to effect tripping of the RCD2.

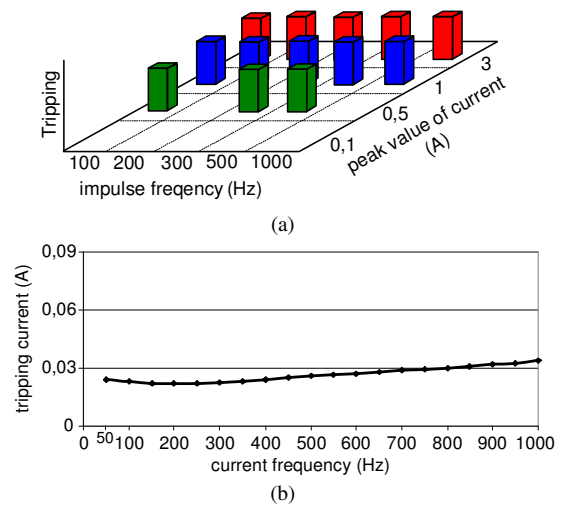

Fig. 8. Response of the RCD1 (30 mA, type A, 50 Hz–400 Hz) to testing impulse current (a) and RCD1 tripping characteristics as a function of residual current frequency (b).

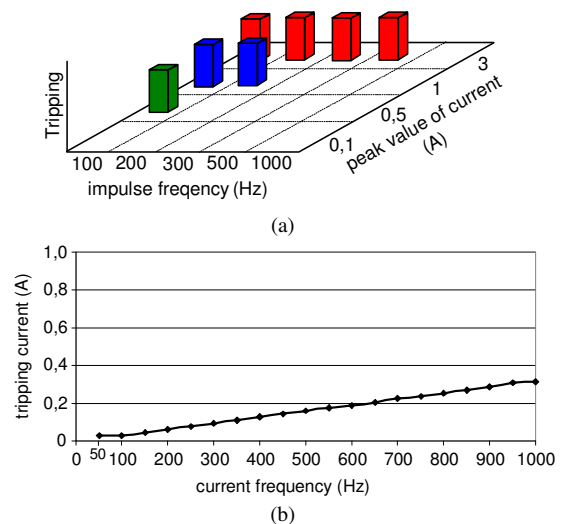

Fig. 9. Response of the RCD2 (30 mA, type AC) to testing impulse current (a) and RCD2 tripping characteristics as a function of residual current frequency (b).

Tripping of the RCD3 is irregular (Fig. 10). Generally, it tripped out at a relatively low impulse frequency (100 Hz and 200 Hz) but occasionally at 1000 Hz and high value of peak current (1 and 3 amperes).

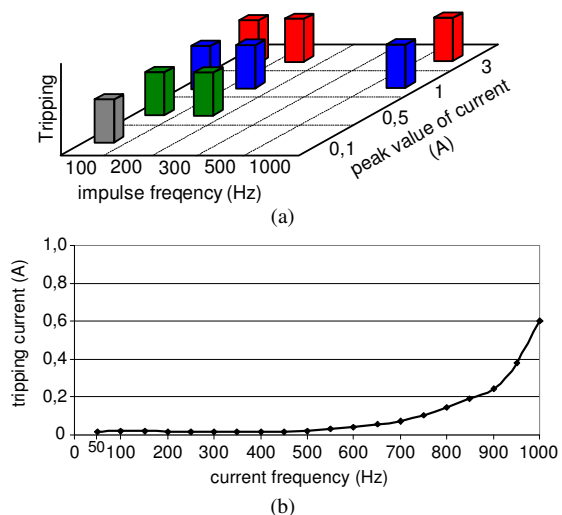

Fig. 10. Response of the RCD3 (30 mA, type A) to a testing impulse current (a) and RCD3 tripping characteristics as a function of residual current frequency (b).

The completely unexpected behavior was recorded in the case of the test of RCD4 (Fig. 11(a)). There was no reaction of RCD4 to the whole range of testing current (both frequency and peak value of the current). Such RCD can be immune to relatively high value of impulse leakage current in real circuits with variable speed drives.

In practice, during the selection of RCDs for circuits with variable speed drives it is difficult to evaluate which RCD has sufficient immunity to the impulse leakage current. Tripping characteristic of particular RCD as a function of residual current frequency (sine wave) can then be helpful.

Comparison of Fig. 8(b), Fig. 9(b), Fig. 10(b) and Fig. 11(b) allows deducing that the RCD which is slightly susceptible to the sine current frequency (Fig. 8(b)) is not immune to the leakage current. RCD strongly susceptible to the sine current frequency has high immunity to the leakage current (Fig. 11(a)).

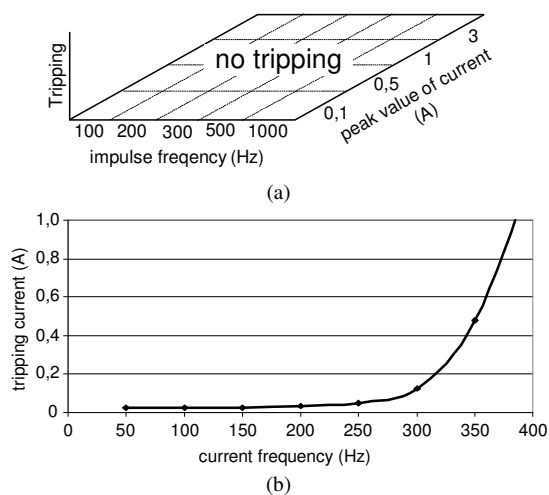

Fig. 11. Response of the RCD4 (30 mA, type A) a to testing impulse current (a); and RCD4 tripping characteristics as a function of residual current frequency (b).

To complete a proper selection of RCD in circuits with variable speed drives, tripping characteristic of RCDs as a function of residual current frequency should be delivered. It is also important in terms of sensitivity of RCD to the earth fault current.

IV. CONCLUSIONS

Residual current devices with high immunity to the leakage current are preferred in modern electrical installations. In practice general purpose RCDs are commonly used. As the laboratory test showed, this type of RCDs has various immunities to the leakage currents. It is difficult to evaluate its properties during the selection process. Only additional laboratory test can deliver suitable information. It is necessary to underline that RCD suitable in terms of the immunity to the leakage current can be unsuitable in terms of the sensitivity to the strong distorted earth fault current. The frequency-tripping current characteristic can be helpful – such characteristic should be delivered by the manufacturer.

REFERENCES

[1] *Low voltage electrical installations – Part 4-41: Protection for safety – Protection against electric shock*, HD 60364-4-41:2007.

[2] *Low voltage electrical installations. Requirements for special installation or locations*, HD 60364-7-7xx.

[3] *General requirements for residual current operated protective devices*, IEC 60755:2008.

[4] S. Czapp, “The impact of higher-order harmonics on tripping of residual current devices”, in *Proc. 13th Int. Power Electronics and Motion Control Conf. (EPE-PEMC 2008)*, Poznan, Poland, Sept. 2008, pp. 2082–2088. [Online]. Available: <http://dx.doi.org/10.1109/EPEPEMC.2008.4635569>

[5] S. Czapp, “The effect of earth fault current harmonics on tripping of residual current devices”, *Przegląd Elektrotechniczny*, no. 1, pp. 196–201, 2009.

[6] J. Guzinski, *Electric drives with induction motors and inverters output filters. Selected problems*. Monograph, Gdansk University of Technology, Gdansk, no. 115, 2011. (in polish).

[7] N. Bagdanavičius, A. Drabatiukas, Š. Kilius, “Lightning discharge parameters in building lightning protection calculations”, *Elektronika ir Elektrotechnika (Electronics and Electrical Engineering)*, no. 3, pp. 103–106, 2009.

[8] J. Schoneck, Y. Nebon, *LV protection devices and variable speed drives. Cahier technique no. 204*. Schneider Electric, 2002.

[9] J. Luszcz, “Motor cable effect on the converter-fed AC motor common mode current”, *Przegląd Elektrotechniczny*, no. 1b, pp. 177–181, 2012.

[10] S. Czapp, D. Swisulski, “The laboratory stand for testing of residual current devices” *The Scientific Papers of Faculty of Electrical and Control Engineering*, Gdansk University of Technology, Gdansk, vol. 27, pp. 29–32, 2008. (in polish).