

Stable and Robust Tension Controller for Middle Section of Continuous Line

Peter Talian, Daniela Perdukova, Pavol Fedor

*Department of Electrical Engineering and Mechatronics, Faculty of Electrical Engineering and Informatics, Technical University of Kosice, Letna 9, 042 00 Kosice, Slovak Republic
daniela.perdukova@tuke.sk*

Abstract—The quality of tension control in the middle section of a continuous processing line significantly affects the quality of the line final product, whether it be the case of sheet metal, pipes, plastic film or paper production. The main requirement is that of constant and non-oscillating tension in the material during all operation states of a line, such as line start-up, line run finish, tension disturbance affects before and after the middle section of the line, changes in parameters (e.g. of the moment of inertia), etc. The paper discusses the design of a stable and robust tension controller for the middle sections of continuous lines designed on basis of the second Lyapunov method, and its application in the middle section of a concrete line with two machines. The properties of the designed control structure were verified by digital simulation in MATLAB. The results achieved confirm the rightness of the proposed control structure which is simple, robust and which can secure stability and good quality dynamics of the controlled system, as well as invariance against disturbances.

Index Terms—Model reference control system; Continuous line; Tension control; Second Lyapunov method.

I. INTRODUCTION

The basic requirement in continuous processing of various materials by means of pulling tension in the area of their elastic or plastic deformations is that for an accurately defined time course of the pull, which in general leads to the requirement for high quality tension control in flexible nonlinear systems with inexactly known parameters and external additive disturbances. This is a relatively difficult task to solve in general, especially for systems with nonlinear and flexible properties and with imprecisely known system description and system parameters, e.g. the flexible coupling and nonlinearities of the system [1]–[4]. It is very often necessary to change and adjust the parameters or sometimes also the structure of the designed controllers directly on the line, which, for one, is time consuming, and also carries the risk that not all possible parametric as well as additive disturbances affecting the line will be considered and tested.

Continuous processing lines represent a multi-motor drive system in which the individual drives are mechanically coupled through the web of material. This system can be regarded as a nonlinear multivariable system the parameters

of which depend on the mechanical properties of the material and on the speed of its motion. Continuous lines as large-scale systems are very often decomposed into many subsystems for web tension control and web speed control. All those subsystems have strong mutual interactions with one other. In a large scale system [5], [6] control decentralization is very often necessary because the system to be controlled is too large and the problems to be solved are too complex. Most industrial web transport systems use decentralized PID or PI type controllers [7]–[9]. These control methods are simple but the coupling between tension and speed limits their performance primarily in dynamic states. Another rather important aspect in these systems is that there exist many uncertainties and disturbances (vibrations, web slipping, roller non-circularity, etc.), which can result in a reduction in quality and even destruction of the material being processed [10]. For this reason the control strategy for continuous technological lines should be robust with respect to the uncertainties and disturbances.

Various robust control methods have been developed. The shortcoming of most robust control structures is the fact that robustness is secured only for a small range of parameter changes [11]–[14], and that they employ rather complex correction networks for securing autonomy [15]–[18]. Research in complex and robust control techniques for web transport systems based on the classical mathematical equation is a topical issue. In [19]–[21] optimal multivariable control methods that are able to reduce the effect of interaction were introduced, but they require an accurate model and parameters. The advanced control methods, such as observed based feedback control [22], [23] and time optimal control [24] are very complicated in terms of both structure and controller parameters design, which is their main drawback in terms of their industrial application.

Due to the fact that multi-motor drives occur in practice as parts of larger technological assemblies, it is necessary to look for such methods of their control that would be simply and easily physically interpretable. Otherwise their wide application in industrial practice cannot be expected.

One of the ways of achieving the above goals is to use control structures with a reference model, designed on basis of Lyapunov's second method suitable also for MIMO systems [25]–[28]. These control structures enable getting a general nonlinear time-variant continuous system into a defined steady state using a prescribed reference model,

while the structural complexity of the designed controllers depends on the suitable choice of the Lyapunov function [29]–[32].

As the design procedure of control structures according to this method contains several optional elements, there generally exist many variations of such structures that can be deduced using the said method.

For the solution of tasks of the above described type this paper proposes a model reference control structure, the stability of which is derived on basis of the second Lyapunov method [33]. The main idea of the method lies in extending the system control algorithm by a new additional piece of information that can be easily obtained from the system's output variable and which will secure that in steady state the control deviation of the output variable will be zero. If we then design line control for this extended system such that will make it asymptotically stable with prescribed dynamics according to the reference model, this will automatically fulfil the desired control goal in steady state, as well as in very good quality in transient states.

The properties of the designed control structure for tension control of the middle section of a continuous processing line were verified by modelling in MATLAB.

II. CONTINUOUS LINE STRUCTURE

Typical representatives of multi-motor drive systems are continuous processing lines, where the individual working machines are coupled with each other through the material. They are, for example, lines for processing continuous flows of material (e.g. sheet metal strips, tubes, processing lines in paper mills and printing works, etc.) by material traction in the field of elastic or plastic deformation, which influences the material's mechanical properties.

In industrial practice many various typical multi-motor drive configurations exist [10] where the pulling tension in the web arises due to different circumferential speeds of the work rolls, or due to the differences in their positions. For simplicity only the coupling of two machines (middle part of continuous line) is investigated, but this idea can be extended to an indefinite number of machines coupled by the processed material.

Figure 1 shows the structure of the middle section of a continuous line (further referred to as CL). The structure includes DC motors powered through static transistor converters TC. The working machines of the line are driven by the motors through gearbox j ; v_1 , v_2 are machine rolls circumferential velocities, F_{12} is the tension in the web of material between the two machines. The main line disturbances are tensions before and after the middle section of the considered line affecting the first and second drive (F_{01} and F_{23}). K_V are circumferential velocity sensors, K_F is the tension sensor, r is roll radius, u_{v1} , u_{v2} are outputs from velocity sensors and u_{F12} is the output of the tension sensor. The control voltages u_1 , u_2 of converters represent the input variables of the system. The tension in the web of material F_{12} and the web of material velocity v_2 are the output variables.

Assume that the converter has proportional transfer and an integrated subordinated current loop, the time constant of which is substantially shorter compared to the time constants of the remaining subsystems of the CL middle

section, so it can be ignored. Assume further that for all sensors the amplification value equals 1, so we will continue with real physical ranges of the particular quantities.

The block diagram of the CL middle section (for Simulink) under these assumptions is shown in Fig. 2.

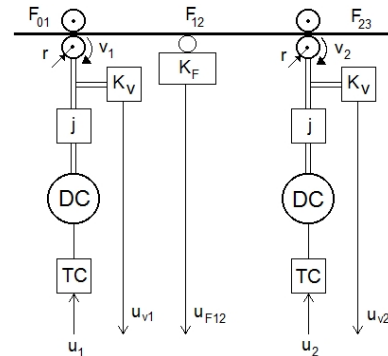

Fig. 1. Structure diagram of middle section of continuous line.

In the block diagram a commonly known model of separately excited DC motor is used. For flexible coupling properties modelling we used the model according to Brandenburg [34]. The physical analysis of the line [35] implies that this system includes a so called “fast” tension subsystem and “slow” speed subsystem, and it is a non-autonomous system (i.e. these two subsystems influence one another). The parameters of the CL model are specified in the Appendix A.

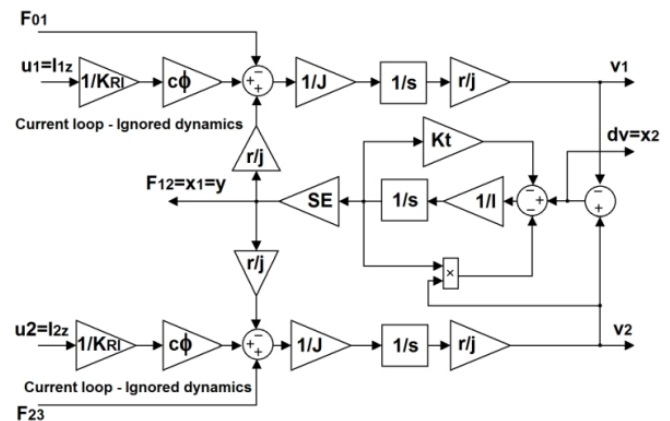

Fig. 2. Block diagram of CL middle section.

In terms of control this is a 3rd order MIMO system with two inputs [$u_1 = I_{1z}$, $u_2 = I_{2z}$] and two outputs [F_{12} ; v_2], which can be influenced by two additive disturbances [F_{01} , F_{23}].

As has already been mentioned, the main goal of control in such systems is precise tension control – it should have a constant and non-oscillating course in all operation stages (start-up, deceleration) and under the influence of disturbances before and after the section of the line under consideration as well as of changes of parameters (e.g. the moment of inertia).

In terms of tension control the controlled system will be a 2nd order system with two inputs [$u_1 = I_{1z}$, $u_2 = I_{2z}$] and one output $y = F_{12}$. The first state variable will be the tension ($F_{12} = x_1$) and we will choose the second state variable to be the difference of the circumferential velocities of the rolls ($dv = x_2 = v_2 - v_1$), where velocity v_2 will be considered as an additional disturbance.

The state description of the middle section of the CL in

terms of tension control according to Fig. 2 has the form:

$$\begin{bmatrix} \frac{dx_1}{dt} \\ \frac{dx_2}{dt} \end{bmatrix} = \begin{bmatrix} -\frac{(K_t) + v_2}{1} & \frac{SE}{1} \\ -\frac{2r^2}{j^2J} & 0 \end{bmatrix} \begin{bmatrix} x_1 \\ x_2 \end{bmatrix} + \begin{bmatrix} 0 \\ -\frac{rc\phi}{jJK_{RI}} \end{bmatrix} u_1 + \begin{bmatrix} 0 \\ \frac{F_{01}r}{jJ} + \frac{F_{23}r}{jJ} + \frac{rc\phi}{jJK_{RI}} u_2 \end{bmatrix}. \quad (1)$$

III. DESIGN OF CONTROL STRUCTURE WITH REFERENCE MODEL FOR MIDDLE SECTION OF CONTINUOUS LINE

The desired dynamical properties of continuous line pulling tension will be prescribed by a reference model, which is as a rule of the same order as the controlled system, generally in the form

$$\frac{dx_M}{dt} = \mathbf{A}_M \mathbf{x}_M + \mathbf{B}_M w, \quad (2)$$

where \mathbf{A}_M is the state matrix of the reference model, \mathbf{B}_M is the reference model inputs matrix, \mathbf{x}_M is the reference model state quantities vector, and w is the desired value.

As for the 2nd order controlled system we need to obtain additional information on the unknown parametrical and also additive disturbances, we will extend its reference model by one state variable $x_{3M} = x_{eM}$, which will secure that in steady state the tension control disturbance is equal to zero. The reference model will be a 3rd order linear system the dynamics of which can be set by a single optional positive parameter α . According to [36] this reference model can secure optimal dynamical properties of the controlled system in terms of the minimal control disturbance and minimal input power criterion.

Then the extended state description of the reference model for the 2nd order system is:

$$\begin{bmatrix} \frac{dx_{eM}}{dt} \\ \frac{dx_{1M}}{dt} \\ \frac{dx_{2M}}{dt} \end{bmatrix} = \begin{bmatrix} 0 & 1 & 0 \\ 0 & 0 & 1 \\ -\frac{\alpha^3}{2} & -\frac{3\alpha^2}{2} & -\frac{3\alpha}{2} \end{bmatrix} \begin{bmatrix} x_{eM} \\ x_{1M} \\ x_{2M} \end{bmatrix} + \begin{bmatrix} -1 \\ 0 \\ 0 \end{bmatrix} w. \quad (3)$$

Note: The tension is generated by the first drive in opposite direction to the line speed, which is represented by the work rolls circumferential velocity v_2 of the second drive.

The block diagram of the considered reference model is shown in Fig. 3.

It is clear in Fig. 3 that in steady state the input of integrator x_{3M} will equal zero and tension will equal the desired value w .

For the controlled system description we will consider a system described by state equations

$$\frac{dx}{dt} = \mathbf{A}x + \mathbf{B}u + \mathbf{d}, \quad (4)$$

where \mathbf{A} is the controlled system state matrix, \mathbf{B} is the controlled system inputs matrix, u is the controlled system input and \mathbf{d} is the time variable vector of unmeasurable additive disturbances.

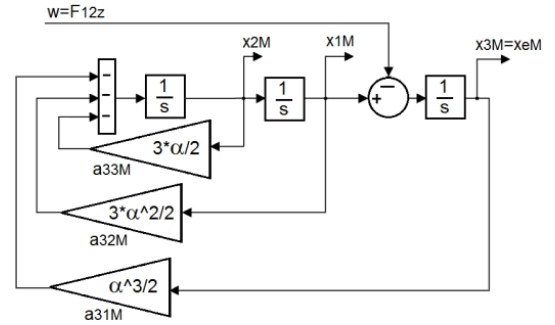

Fig. 3. Reference model for pulling tension control extended by an additional state variable.

In terms of CL middle section tension control this is a 2nd order controlled system which similarly to the reference model will be extended by the output controlled variable integrator. Its state description will then in general be as follows:

$$\begin{bmatrix} \frac{dx_e}{dt} \\ \frac{dx_1}{dt} \\ \frac{dx_2}{dt} \end{bmatrix} = \begin{bmatrix} 0 & 1 & 0 \\ a_{11} & a_{12} & 1 \\ a_{21} & a_{22} & 0 \end{bmatrix} \begin{bmatrix} x_e \\ x_1 \\ x_2 \end{bmatrix} + \begin{bmatrix} 0 \\ 0 \\ b_2 \end{bmatrix} u + \begin{bmatrix} 0 \\ d_1 \\ d_2 \end{bmatrix}, \quad (5)$$

where d_1 and d_2 are unknown additive disturbances and a_{11} , a_{12} , a_{21} , a_{22} are elements of the 2nd order controlled system state matrix \mathbf{A} .

As the goal of electrical drive control is not the zero state of the state vector \mathbf{x} but the zero state of its control deviation from the desired values, it is suitable to choose as state quantities of the system the deviations of state vector \mathbf{x} from the desired values, and also to examine stability with regard to these deviations.

If we establish the reference model and system disturbance as

$$\frac{de}{dt} = dx_M - dx, \quad (6)$$

then through simple adjustments we will obtain a system whose states are constituted by state deviation \mathbf{e} :

$$\frac{de}{dt} = \mathbf{A}_M \mathbf{B}_M + \mathbf{B}_M w - \mathbf{A}x - \mathbf{B}u - \mathbf{d}, \quad (7)$$

$$\frac{de}{dt} = \mathbf{A}_M (\mathbf{x}_M - \mathbf{x}) + (\mathbf{A}_M - \mathbf{A})\mathbf{x} + \mathbf{B}_M w - \mathbf{B}u - \mathbf{d}, \quad (8)$$

$$\frac{de}{dt} = \mathbf{A}_M \mathbf{e} + \mathbf{f} - \mathbf{B}u, \quad (9)$$

where we have denoted

$$\mathbf{f} = (\mathbf{A}_M - \mathbf{A})\mathbf{x} + \mathbf{B}_M w - \mathbf{d}, \quad (10)$$

where \mathbf{f} is the generalized disturbance vector which

comprises all parametrical and additive disturbances affecting the system with regard to its reference model.

The goal of the controller design is to find such mathematical formulation for establishing the input u where the zero solution of the system (9) would be asymptotically stable, i.e. $\lim_{x \rightarrow \infty} \mathbf{e} = 0$.

The Lyapunov function is most often chosen as the weighted quadratic form of system states, because it is positive definite and simple. If we choose the Lyapunov function for system (9) as

$$V = \mathbf{e}^T \mathbf{P} \mathbf{e} = \mathbf{e}^T \mathbf{z}, \quad (11)$$

where \mathbf{z} is the weighted state deviation vector, where for the i -th element it applies that

$$z_i = \sum_{k=1}^n p_{ki} e_k, \quad (12)$$

where p_{ki} are elements of positive definite matrix \mathbf{P} and n denotes the order of the extended controlled system, we can deduce the derivation of Lyapunov function (11) with regard to system (9) as:

$$\frac{dV}{dt} = \mathbf{e}^T (\mathbf{A}_M^T \mathbf{P} + \mathbf{P} \mathbf{A}_M) \mathbf{e} + 2(\mathbf{f}^T \mathbf{z} + b_2 u), \quad (13)$$

$$\frac{dV}{dt} = -\mathbf{e}^T \mathbf{Q} \mathbf{e} + 2(\mathbf{f}^T \mathbf{z} + b_2 u). \quad (14)$$

The zero solution of system (9) will be asymptotically stable if we secure that the Lyapunov function derivation (11) is negative definite. It must then apply that

$$\mathbf{A}_M^T \mathbf{P} + \mathbf{P} \mathbf{A}_M = -\mathbf{Q}. \quad (15)$$

Equation (15) is a matrix Lyapunov equation where matrices \mathbf{P} and \mathbf{Q} are positive definite matrices.

By choosing the reference model according to (3) we can avoid solving (15) as for this reference model the elements of matrix \mathbf{P} according to [36] can be determined analytically, while it applies that $\mathbf{Q} = -\alpha \mathbf{P}$.

Based on the above, for Lyapunov function derivation the following applies:

$$\frac{dV}{dt} = -\alpha \mathbf{e}^T \mathbf{P} \mathbf{e} + 2(\mathbf{f}^T \mathbf{z} + b_2 u), \quad (16)$$

$$\frac{dV}{dt} = -\alpha \mathbf{e}^T \mathbf{z} + 2(\mathbf{f}^T \mathbf{z} + b_2 u), \quad (17)$$

where \mathbf{P} is a positive definite matrix

$$\mathbf{P} = \begin{bmatrix} \frac{\alpha^5}{2} & \alpha^4 & \frac{\alpha^3}{2} \\ \alpha^4 & \frac{5\alpha^2}{2} & \frac{3\alpha^2}{2} \\ \frac{3\alpha^2}{2} & \frac{3\alpha^2}{2} & \frac{3\alpha}{2} \end{bmatrix}. \quad (18)$$

The first element of (17) is always negative, as the expression $\mathbf{e}^T \mathbf{z} = \mathbf{e}^T \mathbf{P} \mathbf{e}$, where $\mathbf{z} = \mathbf{P} \mathbf{e}$ is always positive. System (9) will then be asymptotically stable, i.e. its derivation will be negative, if for input u the following will apply

$$u = -K \mathbf{e}^T \mathbf{z}. \quad (19)$$

Note: The second element of (17) will be negative, if $b_2 u = -b_2 K \mathbf{e}^T \mathbf{z}$ will be larger than $\mathbf{f}^T \mathbf{z}$, which can always be assured by a sufficiently large value of optional positive parameter K .

IV. TENSION CONTROL FOR MIDDLE SECTION OF CONTINUOUS LINE

We consider the state description of the CL middle section in terms of tension according to (1).

We will extend this 2nd order system by an additional state variable x_e according to (5) as follows:

$$\begin{bmatrix} \frac{dx_e}{dt} \\ \frac{dx_1}{dt} \\ \frac{dx_2}{dt} \end{bmatrix} = \begin{bmatrix} 0 & 1 & 0 \\ -\frac{(K_t) + v_2}{l} & \frac{SE}{l} & 0 \\ -\frac{2r^2}{j^2 J} & 0 & 0 \end{bmatrix} \begin{bmatrix} x_e \\ x_1 \\ x_2 \end{bmatrix} + \begin{bmatrix} 0 \\ 0 \\ -\frac{rc\phi}{jJK_{RI}} \end{bmatrix} u_1 + \begin{bmatrix} 0 \\ 0 \\ \frac{F_{01}r}{jJ} + \frac{F_{23}r}{jJ} + \frac{rc\phi}{jJK_{RI}} u_2 \end{bmatrix}. \quad (20)$$

The dynamic properties of tension in the middle section of the continuous line will be prescribed by a reference model according to (3). The optional positive number α in the reference model enables the setting of optimal dynamics of the controlled variable, while it applies that it is inversely proportional to the constant used for settling the dynamical actions in the model. If we need to settle the tension in the web of material within approximately 1s, then based on the Shannon-Kotelnikov theorem the value of the parameter will be $\alpha = 5$.

For generating state quantities deviations of the reference model and the system according to (6) the following modification can be applied

$$\begin{aligned} e_3 &= x_{eM} - x_e = \int x_{1M} dt - \int x_1 dt = \\ &= \int (x_{1M} - x_1) dt = \int e_1 dt. \end{aligned} \quad (21)$$

The controlled system (20) will observe the reference model, and $\lim_{x \rightarrow \infty} \mathbf{e} = 0$ will apply, i.e. the controlled system

will be asymptotically stable if we calculate input u according to (19), where vector \mathbf{z} is

$$\mathbf{z} = \mathbf{P} \mathbf{e}. \quad (22)$$

With regard to the selection of the reference model

according to (3) the elements of matrix \mathbf{P} were determined from matrix (18) for $\alpha = 5$.

For the elements of vector \mathbf{z} it then follows:

$$z_1 = p_{11}e_1 + p_{12}e_2 + p_{13}e_3, \quad (23)$$

$$z_2 = p_{21}e_1 + p_{22}e_2 + p_{23}e_3, \quad (24)$$

$$z_3 = p_{31}e_1 + p_{32}e_2 + p_{33}e_3, \quad (25)$$

and input u will equal

$$u = -K(e_1z_1 + e_2z_2 + e_3z_3). \quad (26)$$

The resulting schematic of CL middle section tension control is shown in Fig. 4.

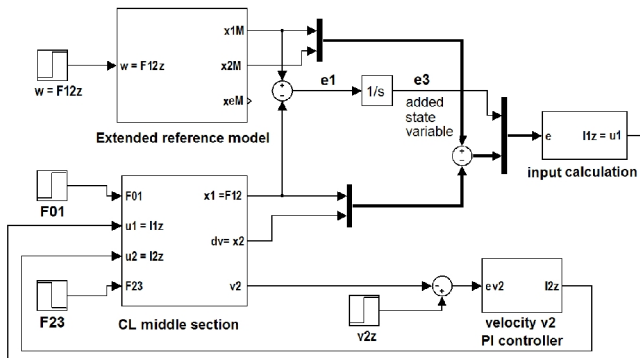

Fig. 4 Block diagram of CL tension control.

For continuous line speed control (v_2 – circumferential velocity of second drive work rolls) a simple standard PI controller was used, as in this case the main target is the quality of tension control. As mentioned above, for the proposed controller the change in velocity v_2 represented another additive disturbance.

V. VERIFICATION OF THE PROPOSED CONTROL STRUCTURE AND DISCUSSION

From the point of view of production technology it is required that the drive system of the continuous line ensures the required value of tension in the web independent from its speed. The goals of the system's control are the following:

- Autonomous setting of controlled line variables, such as speed and tension of the line, i.e. system decoupling.
- Invariance against tension disturbances caused primarily by change of speed v_2 , which represents an external slowly changing disturbance, and by the tension disturbances before and after the line section under consideration. (i.e. disturbances in load torque of the drive – F_{01} , F_{23}).
- Robustness against line parameter changes (damping constant changes, changes of the drives' moment of inertia).
- Desired dynamics for every controlled variable (adjustment of tensions without overshoot).

The properties of the proposed control structure for tension control of the middle section of a continuous line were verified by digital simulation in MATLAB for the so called CL operation cycle, which includes three stages – start-up, line running at constant operational speed, and line

run finish. The CL parameters used in the simulation are listed in the Appendix A.

When verifying the properties of the designed control we assumed the influence of two types of external (additive) disturbances on the CL middle section, namely:

- step changes of tension before (F_{01}) and after (F_{23}) the line section under consideration from zero value to the value of 80 % of the nominal tension in time $t = 3$ s and $t = 6$ s, as demonstrated in Fig. 5;
- the slowly changing line speed v_2 which was controlled by a standard PI controller (the PI controller parameters are listed in the Appendix A). The time plot for line speed v_2 for the desired value equal to the nominal speed, i.e. $v_2 = 0.6 \text{ ms}^{-1}$ is shown in Fig. 6.

The designed control structure was derived on basis of the second Lyapunov method which delimits the range of its optional parameters, i.e. the values of the elements of matrix \mathbf{P} and the parameter K , for which the controlled system as a whole will be stable.

The elements of matrix \mathbf{P} are computed from the Lyapunov matrix equation (15), where a positive definite matrix \mathbf{Q} has to be chosen. The magnitude of the elements of matrix \mathbf{Q} (and therefore also of matrix \mathbf{P}) influences the rate of decay of the Lyapunov function (11), i.e. the rate of decay of control deviation e . The system (9) will be stable for any chosen elements of matrix \mathbf{Q} as long as the condition of positive definiteness is satisfied. If, however, we chose a reference model such that will secure optimal dynamical properties of the controlled system in terms of the minimal control deviation and minimal input power [36], we can avoid solving the Lyapunov matrix (15), because the elements of matrix \mathbf{P} can be determined analytically according to (18), as demonstrated in Chapter III.

The proposed tension control structure includes one optional parameter K in (17) for calculating input u , and this parameter has to be positive and sufficiently large to secure asymptotic stability of the controlled system ((15) Chapter III.). On the other hand, its size is limited by physical limitations in the controlled system, such as motor currents in case of electrical drives, the dynamics of real converters, etc.

The dynamical performance of the output controlled variable of tension F_{12} for the concerned operation cycle and for the value of parameter $K = 2$ (or $K = 5$) is illustrated in Fig. 7. It is evident that tension in the middle section of the continuous line practically follows the tension prescribed by the reference model during the whole operation cycle, and it does so even when influenced by step disturbances at its input and output at time $t = 3$ s and $t = 6$ s (Fig. 5), and also under the influence of all changes of speed (Fig. 6), which fact verifies the invariance of the proposed control against additive disturbances. For the value of parameter $K = 5$ we obtain a better course of tension, which corresponds with better satisfaction of the asymptotic stability condition in (19).

The robustness of the proposed control structure was verified for changes in the two most important controlled system parameters that significantly influence the properties of flexible coupling, namely damping of the material being processed (material elasticity), and the moment of inertia of the drives (pulling thicker sheet metal, material weld).

Figure 8 and Fig. 9 show the time plots of tension F_{12} for as much as fivefold reduced material damping (i.e. five times more elastic material) and for a twofold increase of the drives' moment of inertia (parameter $K = 2$).

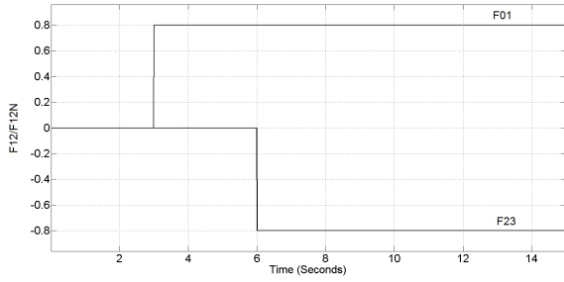

Fig. 5. Time plots of external disturbances under CL middle section control.

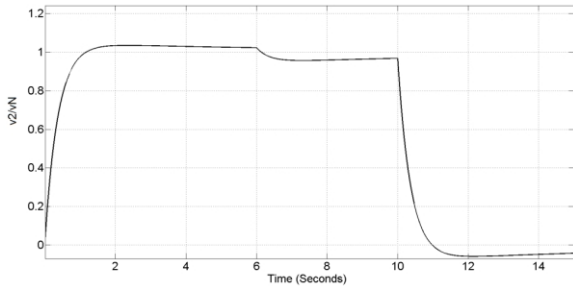

Fig. 6. Time plot of velocity v_2 control in CL middle section.

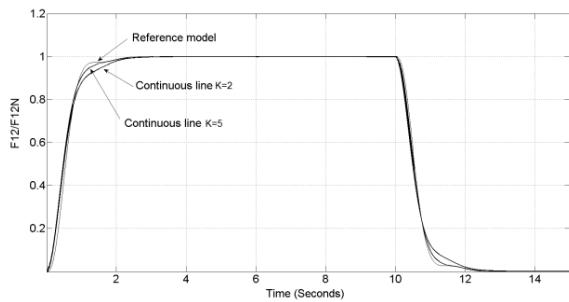

Fig. 7. Time plot of tension control of CL middle section.

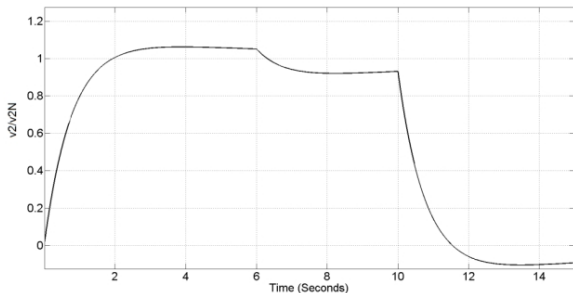

Fig. 8. Time plot of velocity v_2 control in CL middle section for $K_t = 0.2 \times K_{tN}$ and $J = 2 \times J_N$.

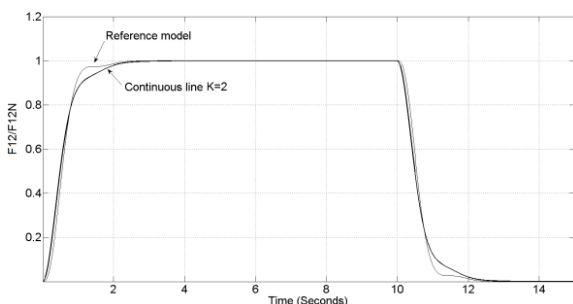

Fig. 9. Time plot of CL middle section tension control for $K_t = 0.2 \times K_{tN}$ and $J = 2 \times J_N$.

Similarly, Fig. 10 and Fig. 11 show the dynamics of speed and tension control for the case when damping of the web of material in the line was increased fivefold, and there was a twofold reduction of the drives' moment of inertia (parameter $K = 2$). In view of the real world operation of the line these are significant and boundary changes of values of the parameters under consideration. In both cases external disturbances exert their influence on the line before and after the considered section of the line, as illustrated in Fig. 5. It is clear from the quoted figures that the dynamics, autonomy and invariance of tension control practically did not change with the significant change of the parameters considered, which fact points at the strong robustness of the proposed controller.

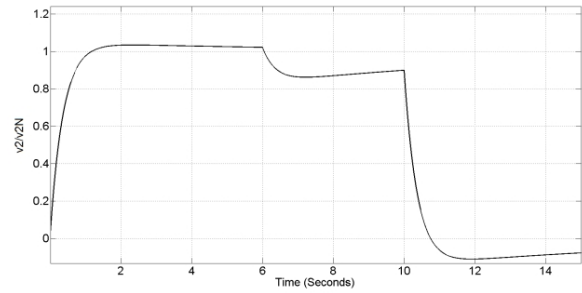

Fig. 10. Time plot of velocity v_2 control in CL middle section for $K_t = 5 \times K_{tN}$ and $J = 0.5 \times J_N$.

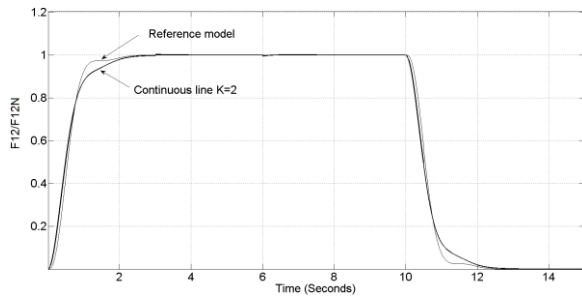

Fig. 11. Time plot of CL middle section tension control for $K_t = 5 \times K_{tN}$ and $J = 0.5 \times J_N$.

In order to tackle the problem of robust tension control, various methods (H-infinity, optimal control) are described in the literature. These methods lead to relatively complex control structures and complicated computations of their parameters, and their main disadvantage lies in the fact that they can secure robustness of control only for a certain limited range of changes of these parameters [11]–[14], and the decoupling of the individual subsystems (autonomy) is solved by the application of various types of correction networks [15]–[17]. On the other hand, the control structure proposed in this paper is very simple, and there is no need for a mathematical model of the system for the calculation of the controller parameters (20). The dynamical properties of tension setting are in general prescribed by a linear reference model in state space (2), and stability is secured by computing the parameters (the elements of positive definite matrix \mathbf{P}) using the Lyapunov matrix (15) and by choosing a positive parameter K .

Based on the results of the proposed control structure verification, it is possible to state that the control structure is stable and strongly robust, and autonomy of the CL output quantities, the desired dynamics and invariance to the

influence of additive disturbances are secured.

Controller synthesis requires data about all state quantities of the controlled system, which is the main disadvantage of the proposed stable control structure. However, the state quantities can be obtained either by measurement or from various types of observers.

VI. CONCLUSIONS

The paper deals with the design and verification of a new stable control structure with reference model for the control of tension in the middle section of a continuous processing line. The basic idea lies in generating additional information (a new suitable state variable) into the controlled system that would enable the achievement of zero control deviation in steady state. The controller is then designed as such that would secure asymptotic stability of the extended system and by this automatically also zero control deviation based on the application of principles of the second Lyapunov method.

As regards control of the continuous line output quantities (tension and speed), the control is decentralized, because the speed and tension subsystems of the line were considered as independent systems and the coupling between them was regarded as a disturbance. The controller for each subsystem was then designed independently.

The properties of the proposed control structure were verified by simulation. The main advantage of the proposed control structure is its strong robustness over a wide range of changes of significant parameters of the controlled system, together with fulfilment of other defined objectives of control of such dynamical systems, i.e. invariance and desired dynamics prescribed by the reference model both in transient and in steady states. What is more, the Lyapunov synthesis tools guarantee the stability of the whole controlled system.

The proposed control strategy is very simple, the obtained simulation results have shown it to be effective for tension control in continuous lines and applicable also in other types of nonlinear systems of similar structure, and therefore it is possible to assume its wide application in industrial practice.

APPENDIX A

Parameters of CL used for simulation:

A. DC motors

$U_N = 24$ V, $n_N = 3650$ rpm-s, $R_a = 0.7$ Ω , $I_N = 8.5$ A, $P_N = 140$ W, $J = 0.002$ kgm², $M_N = 0.37$ Nm, $L_a = 0.1$ mH, $j = 24$, $c\phi = 0.043$ Vs, $v_{max} = 0.6$ ms⁻¹, $I_{max} = 20$ A, $F_{12N} = 25$ N, $K_{R1} = 1$ V/A (current sensor).

B. Processed material

$b = 0.03$ m, $h = 0.1 \cdot 10^{-3}$ m, $S = bh = 3 \cdot 10^{-6}$, $E = 1.8 \cdot 10^9$ Nm⁻², $SE = 5400$ N, $T_{12} = 2.25$ s, $l_{12} = 1.35$ m,

$$K_t N = \frac{Jj^2}{T_{12} 2r^2} = 160 \text{ kgs}^{-1}.$$

C. Work rolls

$r = 0.04$ m.

D. Reference model

$\alpha = 5$.

E. Parameters of PI controller of velocity v_2

$K_P = 20$, $K_I = 2$.

REFERENCES

- [1] J. Zilkova, P. Girovsky, M. Batmend, "Modelling the technological part of a line by use of neural networks", *Advances in Intelligent Systems and Computing*, vol. 239, pp. 349–358, 2014. DOI: 10.1007/978-3-319-01854-6_36.
- [2] J. Li, S. H. Liu, L. J. Cai, "Coupling model and controller design for four-layer register system", in *Proc. Int. Conf. Mechatronics, Manufacturing and Materials Engineering (MMME 2016), MATEC Web of Conferences*, 2016. [Online]. DOI: 10.1051/04023.
- [3] R. N. Norris, "Sectional electric drive for paper machines", *Trans. American Institute of Electrical Engineers*, vol. XLV, pp. 496–511, 2009. DOI: 10.1109/JAIEE.1926.6537596.
- [4] M. Valenzuela, J. Bentley, R. Lorenz, "Evaluation of torsional oscillations in paper machine sections", *IEEE Trans. Industry Applications*, vol. 41, no. 2, pp. 493–501, 2005. DOI: 10.1109/TIA.2005.844383.
- [5] X. Q. Shi, D. E. Davison, R. Kwong, E. J. Davison, "Optimized decentralized control of large scale systems", in *Proc. 12th IEEE Int. Conf. Control and Automation (ICCA)*, 2016. DOI: 10.1109/ICCA.2016.7505264.
- [6] P. R. Pagilla, N. B. Siraskar, R. V. Dwivedula, "Decentralized control of web processing lines", *IEEE Trans. Control Systems Technology*, vol. 15, no. 1, pp. 106–117, 2007. DOI: 10.1109/TCST.2006.883345.
- [7] N. H. Priya, P. Kavitha, N. M. S. Srinivasan, K. Ramkumar, "Design of PSO-based PI controller for tension control in web transport systems", in *Proc. Int. Conf. Soft Computing Systems*, 2015, pp. 509–516. DOI: 10.1007/978-81-322-2674-1_47.
- [8] B. Allaoua, A. Laoufi, B. Gasbaoui, "Multi-drive paper system control based on multi-input multi-output PID controller", *Leonardo Journal of Sciences*, vol. 16, pp. 59–70, 2010.
- [9] B. Bouchiba, A. Hazzab, H. Glaoui, F. Med-Karim, I. K. Bousserhane, P. Sicard, "Decentralized PI controller for multimotors web winding system", *Journal of Automation, Mobile Robotics & Intelligent Systems*, vol. 6, no. 2, pp. 32–36, 2012.
- [10] B. Jefteniu, M. Bebiu, S. Statkiu, "Controlled multi-motor drive", in *Proc. Int. Symposium on Power Electronics, Electrical Drives, Automation and Motion (SPEEDAM 2006)*, IEEE, 2006.
- [11] H. Koc, D. Knittel, M. de Mathelin, G. Abba, "Modeling and robust control of winding systems for elastic webs", *IEEE Trans. Control Systems Technology*, vol. 10, no. 2, pp. 197–208, 2002. DOI: 10.1109/87.987065.
- [12] A. Benlatreche, D. Knittel, E. Ostertag, "Robust decentralised control strategies for large-scale web handling systems", *Control Engineering Practice*, vol. 16, no. 6, pp. 736–750, 2008. DOI: 10.1016/j.conengprac.2006.03.003.
- [13] G. T. Lee, J. M. Shin, H. M. Kim, J. S. Kim, "A web tension control strategy for multi-span web transport systems in annealing furnace", *ISIJ International*, vol. 50, no. 6, pp. 854–863, 2010. DOI: 10.2355/isijinternational.50.854.
- [14] N. Giannoccaro, T. Nishida, T. Sakamoto, "Decentralized H ∞ based control of a web transport system", in *Proc. of the 18th IFAC World Congress*, Milano (Italy), pp. 8651–8656, 2011. DOI: 10.3182/20110828-6-IT-1002.01284.
- [15] B. Shafiei, M. Ekramian, K. Shojaei, "Robust tension control of strip for 5-stand tandem cold mills", *Journal of Engineering*, 13 pages, 2014. DOI: 10.1155/2014/409014.
- [16] X. Zhang, Q. Zhang, "Robust control of strip tension for tandem cold rolling mill", in *Proc. 30th Chinese Control Conf. (CCC 2011)*, pp. 2390–2393, 2011.
- [17] H. R. Koofgar, F. Sheikholeslam, S. Hosseinnia, "Unified gauge-tension control in cold rolling mills: a robust regulation technique", *International Journal of Precision Engineering and Manufacturing*, vol. 12, no. 3, pp. 393–403, 2011. DOI: 10.1007/s12541-011-0051-6.
- [18] P. R. Pagilla, N. B. Siraskar, R. V. Dwivedula, "Decentralized control of web processing lines", *IEEE Trans. Control Systems Technology*, vol. 15, no. 1, pp. 106–117, 2007. DOI: 10.1109/TCST.2006.883345.
- [19] W. Zhao, X. Ren, "Adaptive robust control for four-motor driving servo system with uncertain nonlinearities", *Control Theory and Technology*, vol. 15, no. 1, pp. 45–57, 2017. DOI: 10.1007/s11768-017-5120-7.
- [20] S. Tan, L. Wang, J. Liu, "Research on decoupling method of thickness and tension control in rolling process", in *Proc. IEEE 11th*

- World Congress on Intelligent Control and Automation (WCICA 2014)*, pp. 4715–4717, 2014. DOI: 10.1109/WCICA.2014.7053510.
- [21] G. Pin, V. Francesconi, F. A. Cuzzola, T. Parisini, “Adaptive task-space metal strip-flatness control in cold multi-roll mill stands”, *Journal of Process Control*, vol. 23, no. 2, pp. 108–119, 2013. DOI: 10.1016/j.jprocont.2012.08.008.
- [22] K. C. Lin, “Observer-based tension feedback control with friction and inertia compensation”, *IEEE Trans. on Control Systems Technology*, vol. 11, no. 1, pp. 109–118, 2003. DOI: 10.1109/TCST.2002.806464.
- [23] S. H. Song, S. K. Sul, “A new tension controller for continuous strip processing line”, *IEEE Trans. Industry Applications*, vol. 36, no. 2, pp. 633–639, 2000. DOI: 10.1109/28.833782.
- [24] A. Angermann, M. Aicher, D. Schroder, “Time optimal tension control for processing plants with continuous moving webs”, in *IEEE 35th Annual Meeting-IEEE Industry Applications Conf.*, 1999. DOI: 10.1109/IAS.2000.882671.
- [25] H. Butler, *Model reference adaptive control: from theory to practice*. Prentice Hall, 1992, pp. 80–113.
- [26] I. Landau, *Adaptive Control*. London: Springer, 2011, pp. 523–541. DOI: 10.1007/978-0-85729-664-1_16.
- [27] M. Orsag, C. Korpela, S. Bogdan, P. Oh, “Lyapunov based model reference adaptive control for aerial manipulation”, in *Proc. Int. Conf. Unmanned Aircraft Systems (ICUAS)*, 2013, pp. 966–973. DOI: 10.1109/ICUAS.2013.6564783.
- [28] T. Minan, J. Cao, Y. Xiaoxiao, W. Xiaoming, G. Baohui, “Model reference adaptive control based on Lyapunov stability theory”, in *Proc. 26th Chinese Control and Decision Conf. (CCDC 2014)*, 2014, pp. 1828–1833, DOI: 10.1109/CCDC.2014.6852467.
- [29] M. Sassano, A. Astolfi, “Dynamic Lyapunov functions”, *Automatica*, vol. 49, no. 4, pp. 1056–1067, 2013. DOI: 10.1016/j.automatica.2013.01.027.
- [30] V. Lakshmikantham, “Advances in stability theory of Lyapunov: Old and new”, *Systems Analysis Modelling Simulation*, vol. 37, no. 4, pp. 407–416, 2000.
- [31] W. He, Ch. Sun, S. S. Ge, “Top tension control of a flexible marine riser by using integral-barrier Lyapunov function”, *IEEE/ASME Trans. Mechatronics*, vol. 20, no. 2, pp. 497–505, 2015. DOI: 10.1109/TMECH.2014.2331713.
- [32] K. S. Narendra, L. S. Valavani, “A comparison of Lyapunov and hyperstability approaches to adaptive control of continuous systems”, *IEEE Trans. on AC*, vol. 25, no. 2, pp. 243–247, 1980. DOI: 10.1109/TAC.1980.1102316.
- [33] A. M. Lyapunov, *Stability of Motion*. New-York & London: Academic Press, 1966.
- [34] G. Brandenburg, “Ein mathematisches modell fur eine durchlaufende Stoffbahn in einen System angetriebener umschlungener Walzen”, *Regelungstechnik und Prozess – datenverarbeitung*, vol. 21, no. 3, pp. 69–104, 1973. (in German).
- [35] D. Perdukova, P. Fedor, J. Timko, “Modern methods of complex drives control”, *Acta Technica CSAV*, vol. 49, no. 1, pp. 31–45, 2004.
- [36] V. D. Furasov, *Ustojcivost’ dvizenija, ocenki i stabilizacija*. Moskva: Nauka, 1977, pp. 213–220. (in Russian).