

Electronic Invasive Blood Pressure Simulator Device for Patient Monitor Testing

J. Kijonka, M. Penhaker

*VSB–Technical University of Ostrava, FEECS, Department of Measurement and Control,
17. listopadu 15, 708 33, Ostrava-Poruba, Czech Republic Phones: +420 597 325 280, +420 597 323 510,
e-mails: jan.kijonka@vsb.cz, marek.penhaker@vsb.cz*

crossref <http://dx.doi.org/10.5755/j01.eee.122.6.1820>

Introduction

This engineering solution is concerned in a programmable invasive blood pressure simulator, fall into the technical field and biomedical engineering. The device is intended for the invasive blood pressure (IBP) simulation and its output parameters are suitable for patient's monitor testing and calibrating.

Blood pressure (BP) is one of the principal vital signs. Blood pressure measuring can be provided by invasive or non-invasive methods. Invasive methods are based on invasive blood pressure (IBP) measurement through an arterial line. An arterial line is a thin catheter inserted into an artery. For measuring pressures in the hearth, we usually use a Schwanz-Ganz catheter placed into the pulmonary artery. Invasive arterial pressure measurement with intravascular cannulae involves direct measurement of arterial pressure. The cannula needle is placed in the artery (usually radial, femoral, dorsalis pedis or brachial). The cannula must be connected to a sterile, fluid-filled system, which is connected to an electronic pressure transducer. An output of the IBP transducer is get to the visualization system, usually patient's monitor with IBP module input channel. The measurement BP invasively through an arterial line is the most accurate method of BP measurement. This invasive technique is regularly employed in human intensive care medicine, anesthesiology, and for research purposes since the 1950s. Cannulation for invasive vascular pressure monitoring is infrequently associated with complications such as thrombosis, infection, and bleeding. Patients with invasive arterial monitoring require very close supervision. It is generally reserved for patients where rapid variations in arterial pressure are anticipated. The advantage of this system is that pressure is constantly monitored beat-by-beat and a waveform (a graph of pressure against time) can be displayed.

IBP measurement on a real patient is usually restricted to a hospital setting. IBP waveform visualization, testing and calibrating the patient monitor IBP module requires a special device, which is able to generate an IBP signal. These devices are usually called "patient simulators" for generating signals of vital functions. They usually offer comprehensive simulation with a wide range of features for ECG, NIBP, IBP, temperature and respiration simulation. The use of patient simulators is increasing in healthcare education.

Problem definition

There are many expensive patient simulators with wide range of features for ECG, NIBP, IBP, temperature and respiration simulation in the market. However, sometimes we don't use all of these features. ECG, NIBP, temperature and respiration is possible to measure without any special requirements restricted to a hospital setting. Principal functions of these patient monitor modules can be tested on any volunteer. However, checking the function and testing the IBP module is problematic.

Possibilities and parameters of common devices for IBP simulating: input/output impedance: 300 Ω , exciter input voltage range: 2 V to 16 V, output sensitivity: 5 $\mu\text{V}/\text{V}/\text{mmHg}$ or 40 $\mu\text{V}/\text{V}/\text{mmHg}$, output range: -10 mmHg to 300 mmHg, accuracy \pm (1 % of full range + 1 mmHg) at 80 BPM, RS232 interface for remote control via PC, several channels for generating the IBP: atmosphere (0), arterial = 120/80, central venous pressure = 15/10, left ventricle = 120/0, right ventricle = 25/0, pulmonary artery = 25/10, pulmonary artery wedge = 10/2, static = -10, -5, 0, 20, 40, 80, 100, 200, 250, 300 (manual or auto-stepping at 12-s intervals), triangle = 30.2 Hz, triangle = 300.2 Hz, Schwan-Ganz: start, insert, inflate, deflate, and remove.

Common multifunction patient simulator allows simulate dynamic and static invasive pressure waves from a

predefined set of simulations. Static pressure can be set by fixed steps. Generating of functions is limited to one function (usually triangle) with fixed frequencies. The RS232 interface is determined for remote control via PC. This interface doesn't handle programming generated signals and uploading firmware. Change of shape, amplitude and frequency of generated signals is problematic and inaccessible for a user. User interface visualization LCD informs user only about several parameters of generated signal. The user is not informed about the output voltage and exciter input voltage. These values are necessary for checking the function and testing the patient monitor IBP module (accurate value of exciter input voltage, checking the corresponding value of output voltage). Measurement of the amplified single ended output voltage of the IBP simulator is unavailable in common patient simulators.

In this paper, we present a low-cost programmable IBP simulator, which solves disadvantages of common patient simulators mentioned above.

New solution

In fig. 1 it's shown a measuring network for IBP intracardial measurement and IBP waveform simulation. For an IBP simulation, we substitute the intracardial measurement block by an IBP waveform simulator block.

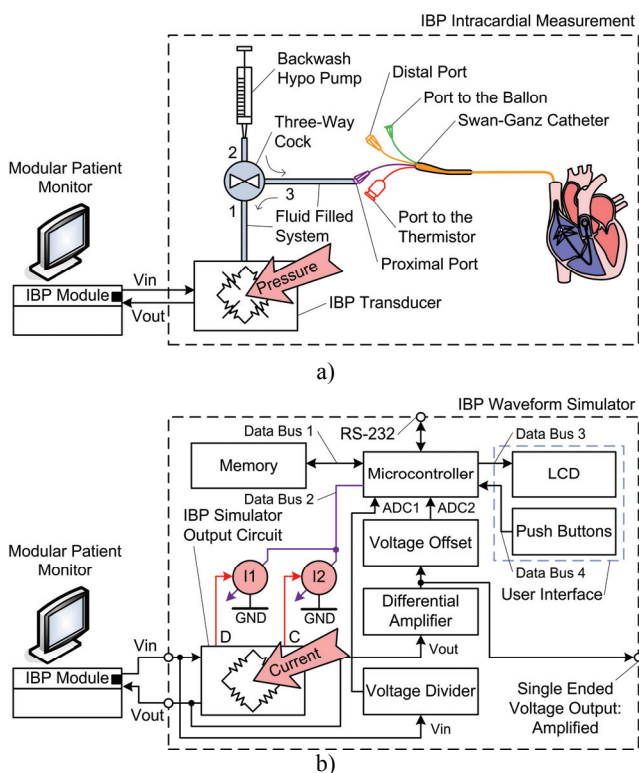

Fig. 1. Measuring network for IBP intracardial measurement and IBP waveform simulation

Our new solution, how to substitute the IBP measurement block by the IBP simulator block is based on principle of IBP transducer. The IBP transducer is a passive resistive element, which works as a two-port network. The output low level signal [μV] is linearly dependent on the input exciter voltage [V]. The IBP

transducer is excited by an exciter voltage of patient's monitor IBP module. The exciter voltage range varies depending on IBP module type, but each IBP module has one constant supply voltage stabilized. The IBP transducer inner circuit consists of four strain gauges interconnected to form the full Wheastone bridge. This mounting maximizes the sensitivity of the pressure sensor and improves the non-sensitivity to ambient temperature changes. The IBP affecting on the transducer produces a differential low level signal [μV] on its output terminals. The IBP transducer schematic diagram is shown in Fig. 2.

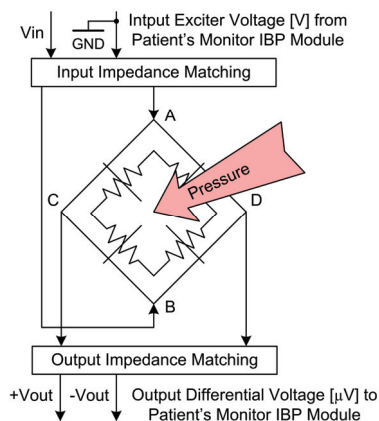

Fig. 2. IBP transducer schematic diagram

We can be inspired with IBP transducer schematic diagram for the IBP simulator output circuit designing. The strain gauges of the Wheastone bridge are replaced by resistors of the same resistance. Like this, we get a modified Wheastone bridge. The output voltage of this modified Wheastone bridge measured between $+V_{out}$ and $-V_{out}$ terminals is always 0 VDC and it is independent of the pressure changes applied on the modified Wheastone bridge. The desired controlled changes of the modified Wheastone bridge output voltage can be obtained by the current sources connected to the C and D nodes of the modified Wheastone bridge (fig. 3). The current source I_1 will be producing a positive potential between $+V_{out}$ and $-V_{out}$ terminals whilst the current source I_2 will be producing a negative potential between the $+V_{out}$ and $-V_{out}$ terminals. It's possible to connect a desired number of current sources to the either C or D nodes, whereas those, connected to the C node, will be producing a positive differential output voltage (V_{out}) whilst those, connected to the D node, will be producing a negative differential output voltage (V_{out}). In addition, all current sources are independently adjustable for maximize flexibility of generated output signal.

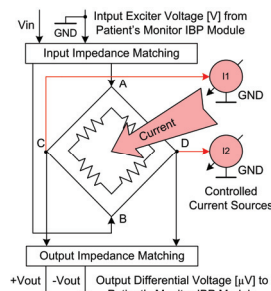

Fig. 3. IBP simulator output circuit schematic diagram

A desired output voltage signal V_{out} is obtained by controlling the current sources. The current sources can be real-time controlled by a microcontroller. By controlling the current sources at selected sampling frequency and with given bit-resolution, the low level voltage output signal is generated on the differential output (V_{out}). For our application, the current sources must have a low level precise output, easy adjustable current range, output linearly dependent on input voltage V_{in} . These requirements match the operational amplifier based circuit shown in fig. 4.

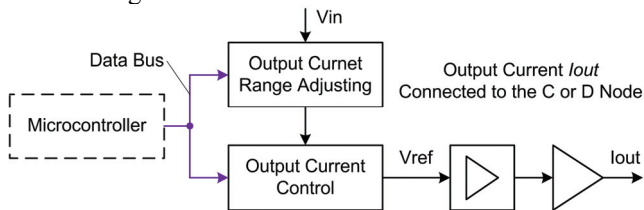

Fig. 4. Current source circuit

The current range adjusting and output current is performed by digital potentiometers. V_{ref} is an input control voltage for a current source.

Principle of Operation. The programmable IBP simulator is composed of a control unit – microcontroller. The microcontroller is interconnected with a memory, storing data of pressure waveform. The microcontroller is also interconnected to a user interface consisted of a LCD unit and some pushbuttons. The user interface performs visualization of exciter input voltage (V_{in}), output voltage (V_{out}) and appropriate output pressure. It allows output sensitivity selecting, pressure offset adjusting, setting the parameters of generated output signal, starting and stopping the output signal generation. The control unit controls minimally one current source. While dynamic pressure is simulated, minimally one current source is continuously controlled with sampling frequency matching the dynamic range of simulated waveform. While static pressure is simulated, minimally one current source is set at the moments of static pressure changes. Minimally one current source is used for pressure waveform simulation, eventually additional current source is used for pressure offset adjusting. Minimally one current source is connected to the C node of the modified Wheatstone bridge (fig. 3). Eventually additional current sources are connected to the D node. The modified Wheatstone bridge output and input impedance match a common IBP transducer. Output voltage terminals V_{out} (IBP simulator output) are get in a special I/O connector for patient monitor interface. Input voltage terminals V_{in} (IBP simulator input) are also get in this I/O connector. The output signal on V_{out} terminals is linearly dependent on the input exciter voltage V_{in} . The IBP waveform simulator has a feedback for monitoring the V_{in} and V_{out} . Differential voltage on the V_{out} terminals is converted to a single ended voltage and the voltage ranges are adjusted to the values suitable for internal reference of microcontroller analog to digital converter (ADC). The V_{in} and V_{out} voltage adjusting for the purpose of reading from ADC inputs is performed by some precise instrumentation and operational amplifiers. The IBP simulator has two additional outputs. One of these outputs is a single ended and amplified output voltage, suitable for

scope or voltmeter measurements. The second output with RS-232 interface allows to remote control via PC, storing the general behaviors of generated signals to the memory and uploading the microcontroller firmware.

Technological benefits. The IBP simulator according to our technical solution allows generating a wide range of output signals from a modifiable waveform set. The generated output signal has a defined range, sampling frequency and a bit-resolution depending on the output current range adjusting, selected data bus bit rate and the output current control (digital potentiometer) bit-resolution. Technological possibilities of the bit-rate and bit-resolution of the generated output signal highly exceed the desired values of these parameters. The output sensitivity is programmable selected by the output current range adjusting. Flexibility of the device is improved by possibility of uploading the control unit and uploading the memory through the RS-232 interface and an application running on a PC. The device disposes an output with single ended amplified output voltage suitable for measurement. A user has supervision of all required measured and computed values on the LCD screen. These possibilities are useful for IBP waveform simulation and patient monitor testing and calibrating.

Implementation of the New Solution

An example of implementation of an IBP waveform simulator is shown in fig. 5. The programmable IBP simulator is composed of a control unit – microcontroller ATmega16 with an integrated flash memory for general behaviors of the generated signal data storing and for control unit program data storing. The microcontroller is interconnected through a 10-bit data bus 1 and a 4-bit data bus 2 to a user interface consisted of a character LCD unit type ATM2004 with four lines of twenty characters and of the four pushbuttons. The user interface performs visualization of exciter input voltage (V_{in}), output voltage (V_{out}) and appropriate output pressure. It allows pressure offset adjusting, setting the parameters of generated output signal, starting and stopping the output signal generation. Additional possibilities of the user interface are selecting the measurement range of ADC1 and ADC2 and LCD backlight intensity setting. The microcontroller is connected to the current sources I_2 and I_3 through a serial peripheral interface (SPI). While dynamic pressure is simulated, the current source I_2 is continuously controlled with a sampling frequency of 200 Hz and 8-bit data resolution. While static pressure is simulated, the current source I_2 is set at the moments of static pressure changes. The current source I_2 is used for pressure waveform simulation in the range from -30 to 300 mmHg and the current source I_3 is used for pressure offset adjusting in the range from -25 to 25 mmHg. The current source I_1 isn't controlled by a microcontroller, but it's adjusted manually at IBP simulator calibration, this current source is used for simulation a constant pressure of -55 mmHg. The current sources I_2 and I_3 are connected to the C node of the modified Wheatstone bridge (fig. 3). The current source I_1 is connected to the D node. The modified Wheatstone bridge output impedance 300 Ω and input impedance from 3710 to 3730 Ω match a common IBP transducer. Output

voltage terminals Vout (IBP simulator output) are get in a special I/O connector for patient monitor interface. Input voltage terminals Vin (IBP simulator input) are also get in this I/O connector. The output signal on Vout terminals is linearly dependent on the input exciter voltage Vin. The IBP waveform simulator has a feedback for monitoring the Vin and Vout. The voltage ranges have to be adjusted to the values suitable for the internal reference of microcontroller analog to digital converter (ADC). The internal reference of the microcontroller ADC is selectable to the ranges of 0 to 2.65VDC or 0 to 5VDC. Differential voltage on the Vout terminals is converted to a single ended voltage by a precise instrumentation amplifier INA101HP with 200-multiple amplification. The INA101HP output voltage get in an offset circuit with Op-amp OP07CP for ensure a positive potential on ADC2 input. The Vin get in an divider circuit with Op-amp OP07CP for ensure a positive potential on ADC1 input. The IBP simulator has one additional output with single ended amplified output voltage from INA101HP, suitable for scope or voltmeter measurements. Storing the general behaviors of generated signals to the microcontroller flash memory and uploading the microcontroller firmware is reserved for a HW programmer. The exciter input voltage range is 1 to 10 V, the output sensitivity is fixed to 5 $\mu\text{V}/\text{V}/\text{mmHg}$.

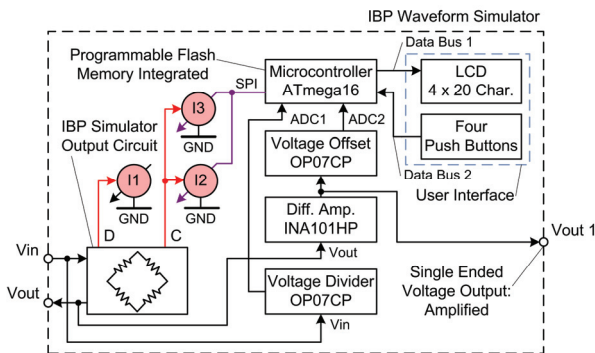

Fig. 5. IBP waveform simulator block diagram

IBP simulator has one channel for generating the IBP signal. Dynamic pressure: one pressure curve, sinus function (amplitude [mmHg] and frequency [Hz] settings). Static pressure: from -30 to 300 mmHg with setting step of 1.3 mmHg, offset from -25 to 25 mmHg with setting step of 0.2 mmHg.

Testing and evaluation

The IBP simulator was tested with modular patient monitor Ekona PM6000. The main purpose of the tests was to determine the accuracy of measured value of Vout and corresponding pressure visualized on LCD of the IBP simulator device for static pressure simulation. For dynamic pressure simulation, the maximal minimal, mean value and the frequency of the generated signal should match the data stored in the IBP flash memory. For generating the sinus function, the amplitude and frequency adjusting should match the generated signal. The results of these tests consider about possibility to use the IBP

simulator for patient monitor IBP module testing and calibration.

Static pressure simulation. The simulator was adjusted to generate the voltage signal corresponding to the constant blood pressure from -30 mmHg to 300 mmHg step 10 mmHg. The values of pressure measured by IBP simulator and patient monitor were compared with the referential value of pressure, measured by the multimeter Escort 3146A. The mean deviation and standard deviation from the referential value of pressure is shown in Table 1.

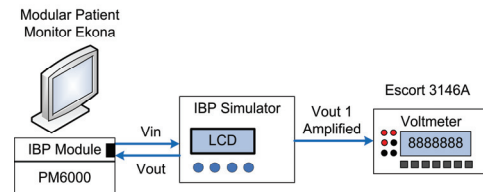

Fig. 6. Measurement network for static pressure simulation

Dynamic pressure simulation. The IBP simulator was adjusted to generate the voltage signal corresponding to physiological blood pressure waveform of defined systolic pressure = 142 mmHg, diastolic pressure = 85.18 mmHg and mean pressure = 104.16 mmHg and frequency 48.24 bpm. Next it was generated the sinus function with selected minimum value = 118.82 mmHg, maximum value = 218.47 mmHg and frequency = 300 bpm. The IBP waveform and sinus function voltage signal generated by the IBP simulator were measured by the oscilloscope Agilent U2702A. The deviation from adjusted values is shown in Table 2.

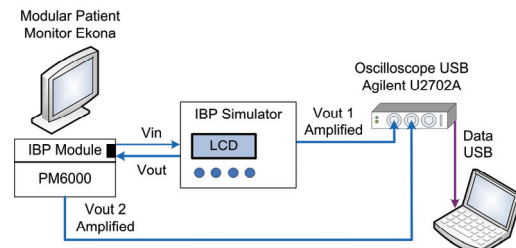

Fig. 7. Measurement network for dynamic pressure simulation

Patient monitor IBP module testing. The patient monitor IBP module testing can be provided by several methods. Some of these methods are shown in fig. 8, 9, and 6 or 7. The method mentioned in fig. 8, requires a BP cuff, which is manually inflated to a required static pressure, which should be invariable for period of stabilizing the value of IBP on patient monitor screen. A problem can appear, if the pneumatic circuit isn't absolutely closed, so that an air can slowly escape. It should be indicated on the manometer scale. The dynamic pressure changes simulation are possible also, but this changes aren't measurable. The voltmeters are composed in the network for Vout amplified signals measurement. The values of Vout corresponding pressures from the patient monitor output and from the IBP transducer output were compared with the adjusted value of pressure. The mean deviation and standard deviation from the adjusted value of pressure is shown in Table 3.

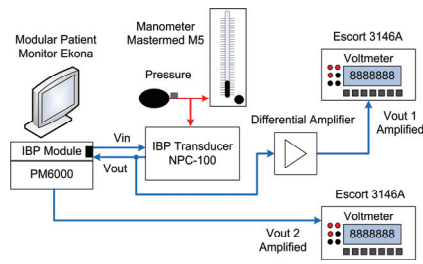

Fig. 8. Patient monitor IBP module testing with IBP transducer, BP cuff and manometer

The method mentioned in fig. 9, requires a BP Pump. BP Pump is an electronic device for NIBP simulation. It also provides a static pressure generation, when the user chooses a required pressure on the output with a 1 mmHg accuracy. The actual pressure is accessible on LCD of the BP Pump device. Testing the patient monitor IBP module is proceeding similarly as in previous method. Relatively quicker descent of the pressure complicates using this method for patient monitor calibrating. The mean deviation and standard deviation from the adjusted value of pressure is shown in Table 1.

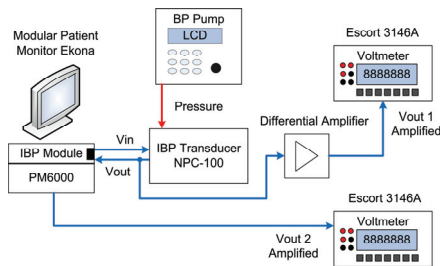

Fig. 9. Patient monitor IBP module testing with IBP transducer and BP Pump

Results – static pressure simulation. For patients monitor testing and calibrating has the best results the IBP simulator for its little mean and standard deviation. Additional benefits are needles of using the pneumatic system, which can be unstable, also an error of reading out the pressure value is removed. Greater deviation has a manometer method and the BP Pump method, because of relatively quick decrease (non-stability) of adjusted pressure. According to the common patient monitor accuracy (± 1 mmHg) are theoretically all of these methods suitable for patient monitor IBP module calibration. However, disadvantage of methods in fig. 8 is impossibility to generating the defined pressure waveform and simulation.

Table 1. Static pressure simulation statistics (mean deviation, standard deviation)

	Mean	Std.	Units
IBP simulator	0.022	0.2736	mmHg
Ekona PM6000	-0.2281	0.5548	mmHg
BP pump	-0.9306	0.8868	mmHg
Ekona PM6000	0.7228	1.1391	mmHg
Manometer	-0.5068	0.5052	mmHg
Ekona PM6000	0.1548	0.9044	mmHg

Results – dynamic pressure simulation. The IBP simulator has a higher pressure deviation most significant

on max pressure (-2.68 mmHg). This is probably caused by not calibrated output signal generation. The calibrating can be performed by data adjustment in the flash memory of the device. The different measured pressure deviation between the pressure measured by Ekona output and the pressure displayed on the Ekona screen reflect a diversity of these outputs and impossibility to calibrate both these outputs simultaneously. Maximum difference between Ekona screen and Ekona output is 3.3 mmHg.

Table 2. Dynamic pressure simulation statistics (deviation)

	Min [mmHg]	Max [mmHg]	Mean [mmHg]	Freq. [bpm]
Waveform - Simulator	-0.38	-2.03	-0.64	-0.81
Waveform - Ekona out.	0.8	-3.18	-0.23	-1.11
Waveform - Ekona scr.	0.18	0.12	1.16	-
Sinus - Simulator	-0.11	-2.68	-0.2	0
Sinus - Ekona output	-2.75	-0.5	-1.31	-2.4
Sinus - Ekona screen	-1.18	0.47	0.04	-

Results – common patient simulators and new solution of IBP simulator. The table 3 represents a comparison between a common patient simulator referred above and the new solution single-purposed one channel IBP waveform simulator. The main benefit is a low-cost, simple solution reaching a good result to patient monitor IBP module testing and calibrating.

Table 3. Common patient simulators and new solution of IBP simulator

Parameter	Common devices	IBP simulator	Units
Input/Output Impedance	300	$\sim 3720/300$	Ω
Exciter Input Voltage Range	2 to 16	1 to 10	VDC
Output Sensitivity	5 or 40	³⁾ 5	$\mu V/V/mmHg$
Output Range	-10 to 300	-30 to 300	mmHg
Offset	-	-25 to 25	mmHg
Accuracy	$\pm (1\% \text{ of full range} + 1 \text{ mmHg})$	⁴⁾ 1.3 mmHg/0.2 mmHg	-
Interface	¹⁾ RS232	⁵⁾ -	-
Channels	1 to 4	1	-

NOTE: ¹⁾ Interface for remote control via PC.

²⁾ Manual or auto-stepping at 12-s intervals.

³⁾ Sensitivity for this implementation is fixed to 5, because of nonprogrammable output current range adjusting for this implementation.

⁴⁾ Resolution of generated signal, static pressure is able to adjusted by offset output control

⁵⁾ No interface included in this implementation, storing the data to the flash memory and uploading the firmware reserved for HW programmer.

Compared to common devices, the implementation offers the possibilities of wide range of programmable output signal generating with possibility of extension of the implementation for programmable variable output sensitivity. The accuracy of the implementation can be increased by increasing the bit-resolution of the output current control. Function generation has also wide possibilities because of relative easy function implementation to the control unit of the device. Some

interface for remote control via PC and for uploading the control unit program and uploading the memory is signed in the design, for our purpose of simulation, testing and calibration the patient monitor modules it wasn't required. All features of the implementation are sufficient for simulation testing and calibrating the patient monitor IBP modules.

Conclusions

The result of this work is design and realization of the electronics invasive blood simulator device for patient monitor testing. This kind of electronic device is necessary for testing the accuracy input parts of medical patient's bedside monitor. Proposed solution in this work is that the testing procedure of electronic monitor part need precise measurement with mean error 0.022 mmHg and standard deviation 0.2736 mmHg. In this case the required precision of measurement of invasive blood pressure is 1 mmHg as standard. This results were successfully proof on EKONA – Mindray PM6000 modular patient which is more and more commonly used in hospitals.

Acknowledgements

The work and the contribution were supported by the project: Ministry of Education of the Czech Republic under Project 1M0567 "Centre of applied electronics",

student grant agency SV 4501141 "Biomedical engineering systems VII" and TACR TA01010632 "SCADA system for control and measurement of process in real time". Also supported by project MSM6198910027 Consuming Computer Simulation and Optimization.

References

1. **Kasik, V.** FPGA based security system with remote control functions // The 5th IFAC Workshop on Programmable Devices and Systems. – Gliwice, Poland, 2001. – P. 277–280.
2. **Brida P., Machaj J., Duha J.** A Novel Optimizing Algorithm for DV based Positioning Methods in ad hoc Networks // Electronics and Electrical Engineering. – Kaunas: Technologija, 2010. – No. 1(97). – P. 33–38.
3. **Machacek, Z., Srovnal V.** Automated system for data measuring and analyses from embedded systems // Proceeding of the 7th WSEAS International Conference on Automatic control, Modeling and Simulation. – Prague, Czech Republic, 2005. – P. 1–6.
4. **Havlík, J., Uhlíř, J., Horčík, Z.** Human Body Motions Classifications // IFMBE Proceedings [CD-ROM]. – Berlin: Springer, 2008.
5. **Brida P., Machaj J., Benikovsky J., Duha J.** An Experimental Evaluation of AGA Algorithm for RSS Positioning in GSM Networks // Electronics and Electrical Engineering. – Kaunas: Technologija, 2010. – No. 8(104). – P. 113–118.

Received 2011 02 15

Accepted after revision 2011 05 23

J. Kijonka, M. Penhaker. Electronic Invasive Blood Pressure Simulator Device for Patient Monitor Testing // Electronics and Electrical Engineering. – Kaunas: Technologija, 2012. – No. 6(122). – P. 49–54.

This work deal with design and realization of invasive blood pressure patient's side bad monitor testing by our original electronic device. Designed device enable to generate precise and wide range of pressure- voltage curve signal for using on any IBP monitors. User adaptive interface with display and control buttons makes it easy for use. The primary applications of these invasive blood pressure simulations are calibrating the patient's monitors that are the general usages of the developed device. III. 9, bibl. 5, tabl. 3 (in English; abstracts in English and Lithuanian).

J. Kijonka, M. Penhaker. Elektroninis invazinis kraujo spaudimo imituoklis paciento monitoriui testuoti // Elektronika ir elektrotechnika. – Kaunas: Technologija, 2012. – Nr. 6(122). – P. 49–54.

Pateikiami paciento kraujo spaudimo monitoriaus testavimo naudojant originalų elektroninį įtaisą projektavimo ir realizavimo aspektai. Sukurtas įtaisas leidžia generuoti tikslų spaudimo-įtampos signalą, kuris naudojamas invaziniuose kraujo spaudimo monitoriuose. Adaptyvus displėjus ir valdymo mygtukai palengvina jo vartojimą. II. 9, bibl. 5, lent. 3 (anglų kalba; santraukos anglų ir lietuvių k.).