

Comparative Evaluation of the Two Current Source Supplied Strain Gauge Bridge

Wojciech Walendziuk¹, Jerzy Golebiowski¹, Adam Idzkowski¹
¹Department of Electrical Engineering, Bialystok University of Technology,
 Wiejska 45D St., 15-351 Bialystok, Poland
 w.walendziuk@pb.edu.pl

Abstract—Metrological properties of a two-current-source bridge circuit were tested with the use of the method of measuring resistance increments of strain gauges. An unconventional system was investigated in comparison with the commonly used Wheatstone's half-bridge, quarter-bridge and Anderson's loop. Input-output characteristics of the systems tested with a current supply were examined experimentally. Error values of offset and gain of the characteristics in relation to the characteristics of reference were taken as the criterion of comparison. Moreover, standard uncertainties of y-intercept and slope coefficients (of the straight lines) were analysed. The coefficients with their uncertainties are presented in tables. Errors for three tested systems with two metal strain gauges or with one semiconductor are presented on graphs. Additionally, the errors change, resulted from the spread of initial resistances as the quantity influencing the uncertainties of offset and gain coefficients, was defined for the bridge circuits.

Index Terms—Temperature sensors; strain measurement; measurement techniques.

I. INTRODUCTION

This article presents an attempt to compare metrological properties of selected direct current supplied systems, *i.e.* a two-current-source bridge [1], a Wheatstone bridge [2]–[4] and an Anderson's loop [5]. It is widely known that the type of the system used in a device influences the linearity of the output voltage and the sensitivity of the system to the measured quantity change [3], [6], [7]. It is described in articles where strain gauge deflection measurements are presented. Works [8], [9] show significant differences between parameters values of a regular voltage supplied quarter-bridge and a two-current-source supplied system. The author of [8], [9] analysed nonlinearity errors and sensitivity changes of the output voltage at a great range of metal strain gauge deflection for both systems. It is only briefly mentioned that the ratio of the output voltage to the supply voltage is two times greater in the Anderson's loop than in the Wheatstone's bridge (at equal power dissipation in its elements). In the Anderson's system it was also possible to obtain a greater ratio of signal to noise (6 dB) [10].

The aim of experiments presented in this paper is to examine the usefulness of a 2J+2R two-current-source bridge in indirect resistance measurements. Other

measurements were conducted at the same time with the use of the same type sensors applied in commonly used systems: a Wheatstone's current supplied bridge and an Anderson's loop. Input-output characteristics of the tested systems were determined experimentally. The values of the obtained offset errors and gain errors towards the characteristics of reference were taken as the criterion of comparison. The authors consider these elements of the article to be original.

II. TESTED DC MEASUREMENT SYSTEMS AND THE REFERENCE SYSTEM

The following systems were tested: 2J+2R two-current-supplied bridge (Fig. 1), Wheatstone's bridge (Fig. 2), Anderson's loop (Fig. 3). A Keithley 2000 multimeter is a reference system (Fig. 4). Two configurations of each system are analysed respectively. First, one with one semiconducting strain gauge R_1 (the range of resistance change – 1 Ω , resistance relative increment – $|\varepsilon_1| \leq 0.01$, $\varepsilon_2 = 0$). And the second one with two metal strain gauges R_1 and R_2 , (the range of the resistance modules mean average – 0.1 Ω , resultant relative increment of sensors resistance – $\varepsilon = 0.5(|\varepsilon_1| + |\varepsilon_2|) \leq 0.001$).

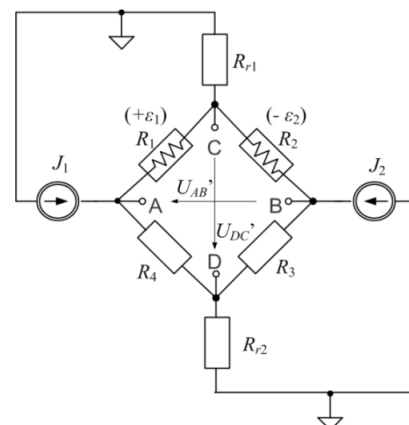

Fig. 1. Two-current-source bridge (2J+2R).

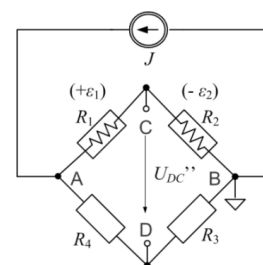

Fig. 2. Wheatstone's bridge.

Manuscript received 22 November, 2016; accepted 8 June, 2016.

The paper was prepared at Bialystok University of Technology within a framework of the S/WE/1/2013 project funded by Ministry of Science and Higher Education.

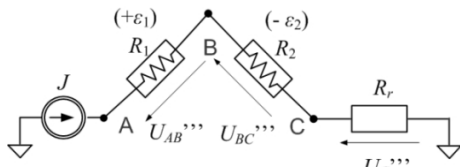

Fig. 3. Anderson's loop (simplified version, without subtractors).

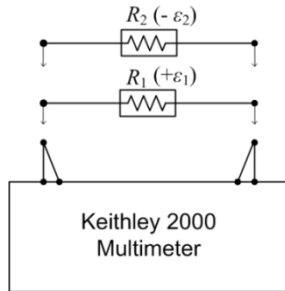

Fig. 4. Direct measurement of resistance with the use of a multimeter (reference system).

The earlier analysis of a two-current-source circuit provided information about the range of linearity of output voltages in the function of resistance relative increments of ε_1 , ε_2 sensors. The range of relative increment of sensors resistance is relevant to the linearity condition of output voltages of a two-current-source bridge, *i.e.* $|\varepsilon_1 + \varepsilon_2| \ll 1$. Laboratory measurements showed that relative errors of the measured increments differences and sums of two resistance variables are not greater than 9.7 %.

The tested systems were built of identical elements, which enabled reliable comparison of characteristics parameters. Additionally, the same sensor (or a set of identical sensors) was used. Strain gauges working conditions were also identical for each case, *e.g.* equal values of power emitted by a sensor (or sensors) and the same temperature of its activity.

III. THE WAY OF STRAIN GAUGES DISTRIBUTION ON A METAL BEAM AND THE BENDING MECHANISM

The strain gauges were stuck on thin, cuboidal beams made of tool steel. On the top surface of the first beam one semiconductor gauge AP 120-6-12 (OPS Gottwaldov) was placed. On the other case, one metal gauge (foil) TF-3/120 (Tenmex) was stuck on each side of the beam (top and bottom), at the same distance from the point of its attachment (Fig. 5).

The resistance increments of the strain gauges ε_1 , ε_2 were imposed by a mechanism deflecting the beam with the use of a micrometer screw gauge and providing a good repetitiveness of the deflections (Fig. 6).

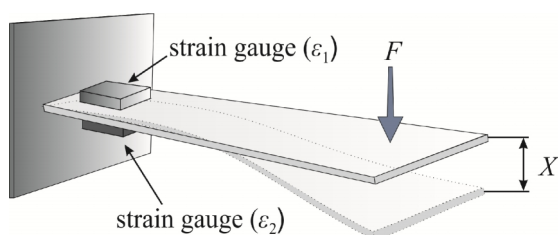

Fig. 5. The way of metal strain gauges distribution on a one-sided attached cantilever beam undergoing deflection (X). Symbols: ε_1 – positive relative increment of the top gauge resistance (the gauge is stretched), ε_2 – negative relative increment of the bottom gauge (the gauge is compressed).

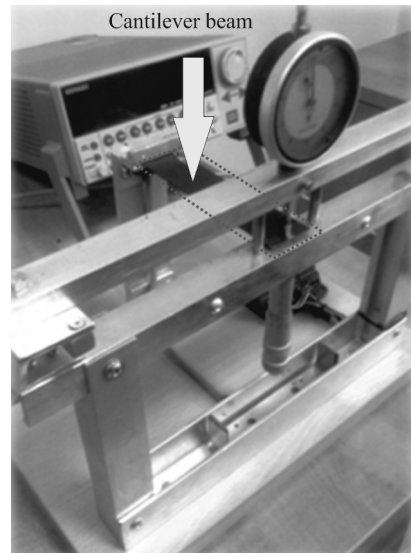

Fig. 6. Laboratory stand with a mechanism enabling simple bending of the beam. The photo presents a cantilever beam being deflected (black dotted line color). The micrometer screw gauge is used to deflect the beam.

IV. AMPLIFIED RELATIVE RESISTANCE INCREMENT IN THE REFERENCE SYSTEM

The resistances of strain gauges in the reference system were measured directly with the use of a precise Keithley 2000 multimeter. The resistance relative increments were multiplied by a constant W . Its value equals the voltage amplification of amplifiers applied to the outputs of the systems shown in Fig. 1–Fig. 3.

The resistance relative empirical increment of a semiconductor strain gauge was determined according to the following equation

$$\varepsilon_{Wi} = W\varepsilon_{li} = W \frac{R_{li} - R_{l0}}{R_{l0}}, \quad (1)$$

where W – constant ($W = 100$ was assumed), R_{li} – measured value of resistance for deflection X_i (where the number of measurements $i = 1$ to 100), R_{l0} – initial resistance of a strain gauge (for deflection $X_1 = 0$ mm).

The resistance average relative empirical increment for a set of two foil strain gauges, however, was determined according to the following equation

$$\varepsilon_{Wi} = W \frac{|\varepsilon_{1i}| + |\varepsilon_{2i}|}{2} = \frac{W}{2} \left(\frac{|R_{1i} - R_{10}|}{R_{10}} + \frac{|R_{2i} - R_{20}|}{R_{20}} \right), \quad (2)$$

where R_{1i} , R_{2i} – measured value of resistance for deflection X_i (where the number of measurements $i = 1$ to 100), R_{10} , R_{20} – initial resistances of strain gauges (for deflection $X_1 = 0$ mm).

V. MEASUREMENT EQUATIONS OF DC TESTED CIRCUITS

The analysed circuit can work with one pair of resistance sensors and may be used to measure two increments, as well as the sum and difference of resistances, at the same time.

The following equations (3) and (4) can be used as the measurement equations for a two-current-source bridge circuit:

$$U_{AB'} \cong V_A - V_B = \frac{JR_0}{4} (\varepsilon_1 - \varepsilon_2), \quad (3)$$

$$U_{DC'} \cong V_D - V_C = \frac{JR_0}{6} (\varepsilon_1 + \varepsilon_2). \quad (4)$$

It is assumed that $J_1 = J_2 = J$ because an inequality of currents results in additional components of (3) and (4). Then the output voltages depend also on a difference of currents ΔJ .

As it can be observed, the voltage $U_{AB'}$ changes for subsequent beam deflections X_i and the $U_{DC'}$ is close to zero. This derives from equations (3), (4) and from the way of strain gauges arrangement on the beam presented in Fig. 5 (during beam deflecting, the increment ε_1 is always positive while ε_2 is always negative, and the modules have the same values $|\varepsilon_1| = |\varepsilon_2|$). After transformations of equation (3), for a circuit with one strain gauge ($\varepsilon_2 = 0$), equation (5) was obtained, and for the circuit with two strain gauges ($\varepsilon_1 > 0 \cap \varepsilon_2 < 0 \Rightarrow \varepsilon_1 - \varepsilon_2 = |\varepsilon_1| + |\varepsilon_2|$) – equation (8), presented in Table II.

Additionally, circuits from Fig. 2 Fig. 3 were analysed, assuming that $R_{10} = R_{20} = R_{30} = R_{40} = R_r = R_0$. As a result, measurement equations of other circuits were obtained. Those equations for different configurations are also included in Table I and Table II.

TABLE I. MEASUREMENT EQUATIONS OF TESTED CIRCUITS.

Circuit with one strain gauge ($\bar{\varepsilon}_W = W\varepsilon_1$)	
Two-current-source bridge (2J+2R)	$\bar{\varepsilon}_W = \frac{4W\bar{U}_{AB'}}{\bar{J}R_0} \quad (5)$
Wheatstone's bridge	$\bar{\varepsilon}_W = \frac{4W\bar{U}_{DC}''}{\bar{J}R_0 - \bar{U}_{DC}''} \quad (6)$
Anderson's loop	$\bar{\varepsilon}_W = \frac{W(\bar{U}_{AB}''' - \bar{U}_{C}''')}{\bar{U}_{C}'''} \quad (7)$

Current \bar{J} , existing in equations (3) and (4), is a mean average of sources \bar{J}_1 and \bar{J}_2 currents. It was measured through voltage decreases \bar{U}_{RJ1} and \bar{U}_{RJ2} on additional resistors $R_{J1} = R_{J2} = R_J$ of low value. In the case of the Wheatstone's bridge circuit, the current of the supply source \bar{J} was measured in the same way.

TABLE II. MEASUREMENT EQUATIONS OF TESTED CIRCUITS.

Circuit with two strain gauges ($\bar{\varepsilon}_W = 0.5W(\varepsilon_1 + \varepsilon_2)$)	
Two-current-source bridge (2J+2R)	$\bar{\varepsilon}_W = \frac{2W\bar{U}_{AB'}}{\bar{J}R_0} \quad (8)$
Wheatstone's bridge	$\bar{\varepsilon}_W = \frac{2W\bar{U}_{DC}''}{\bar{J}R_0} \quad (9)$
Anderson's loop	$\bar{\varepsilon}_W = \frac{W(\bar{U}_{AB}''' - \bar{U}_{BC}''')}{2\bar{U}_{C}'''} \quad (10)$

VI. CRITERION OF CIRCUITS COMPARISON AND DATA ACQUISITION

The values of gain and offset errors of appropriate processing characteristics were taken as the comparison criterion of the tested circuits. The fact of the eleven-fold beam deflection X (Fig. 5, Fig. 6) in each configuration was the starting point of the research. As a result, output voltages (Fig. 1–Fig. 3) occurred. They were amplified one hundred times, measured and averaged (out of 200 samples) in a data acquisition system presented in Fig. 7 (LabJack UE-9Pro). This enabled calculating strain gauges resistance average relative increments $\bar{\varepsilon}_W$ in LabVIEW with the use of equations (5)–(10). Thereafter, measurement results were worked out with the weighted least squares regression method [11]. Estimators of average relative increments $\hat{\varepsilon}_W$ were determined in this way

$$\hat{\varepsilon}_W = a_u X + b_u, \quad (11)$$

where a_u – characteristics gain coefficient of the tested circuit (a_d, a_w or a_p), b_u – characteristics offset coefficient of this circuit (b_d, b_w or b_p), where subscript stand for d – two-current-source bridge, w – Wheatstone's bridge, p – Anderson's loop.

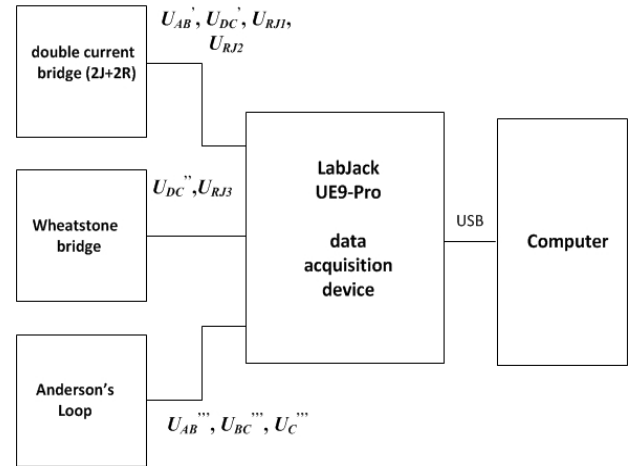

Fig. 7. Output voltages acquisition system of three tested circuits.

Figure 8 presents a geometrical interpretation of absolute gain Δ_n and offset Δ_p errors. Likewise, relative errors of linear regression models of tested circuits were defined [12] in the following way:

$$\delta_n = \frac{\Delta_n}{\varepsilon_{W \max}} \times 100\% = \frac{a_{Kj} - a_u}{a_{Kj}} \times 100\%, \quad (12)$$

$$\delta_p = \frac{\Delta_p}{\varepsilon_{W \max}} \times 100\% = \frac{b_u}{a_{Kj} X_{\max}} \times 100\%, \quad (13)$$

where $\varepsilon_{W \max}$ – measurement range (processing) $\varepsilon_{W \max} = a_{Kj} X_{\max}$, X_{\max} – maximum deflection of the beam, a_{K1} – reference characteristics gain coefficient of a semiconductor strain gauge ($j = 1$), a_{K2} – reference characteristics gain coefficient of two metal strain gauges ($j = 2$).

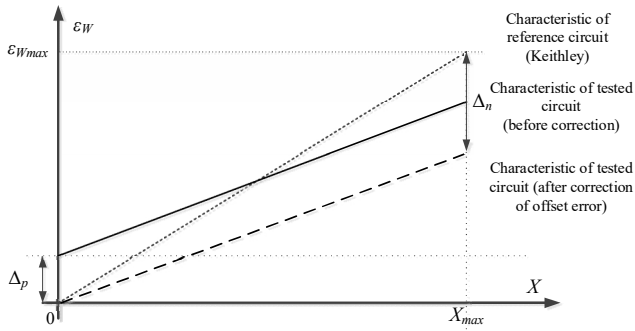

Fig. 8. The way of determining characteristics offset Δ_p and gain Δ_n errors of tested circuits towards the reference characteristics (Keithley).

As it can be observed, errors (12), (13) were determined by comparing linear regression models (determined for three circuits) with a reference model (regarded as close to ideal). Those errors should have possibly smallest values. Reference models were determined regarding the data obtained as a result of gradual, linear deflection of strain gauges and direct measurements of their resistance changes with a precise Keithley 2000 multimeter (Fig. 4). Regression lines $\hat{\varepsilon}_W = a_{K1}X$ and $\hat{\varepsilon}_W = a_{K2}X$ were recognized as reference characteristics. Moreover, coefficients standard uncertainties a_u , b_u of linear regression models (11) were calculated [11].

The proposed comparisons of parameters let us evaluate metrological properties of a two-current-source bridge 2J+2R in collation with classic measurement systems.

VII. UNCERTAINTY ANALYSIS OF REGRESSION LINES COEFFICIENTS

The uncertainties of resistance relative increments were calculated assuming that the input values \bar{U}_{AB}' , \bar{J} in equation (3) were correlated. According to the GUM guide [13], all standard uncertainties were denoted by small letters u . The combined uncertainty of the resistance relative increment $u_c(\bar{\varepsilon}_W')$, considering only $u(\bar{U}_{AB}')$, $u(\bar{J})$ uncertainties, was calculated with the use of equation [13, Annex H]

$$u_c(\bar{\varepsilon}_W') = \sqrt{u^2(\bar{U}_{AB}') \left(\frac{\partial \bar{\varepsilon}_W'}{\partial \bar{U}_{AB}'} \right)^2 + u^2(\bar{J}) \left(\frac{\partial \bar{\varepsilon}_W'}{\partial \bar{J}} \right)^2 + 2 \left(\frac{\partial \bar{\varepsilon}_W'}{\partial \bar{U}_{AB}'} \right) \left(\frac{\partial \bar{\varepsilon}_W'}{\partial \bar{J}} \right) u(\bar{U}_{AB}') u(\bar{J}) r(\bar{U}_{AB}', \bar{J})}, \quad (14)$$

TABLE III. COMPARISON OF PARAMETERS a_u AND b_u OF THE DETERMINED MODELS, THEIR EXPANDED UNCERTAINTIES $U(a_u)$, $U(b_u)$, (FOR $k = 2$ AND $p = 95\%$) AND AVERAGE RELATIVE ESTIMATION ERRORS FOR CIRCUITS WITH ONE SEMICONDUCTOR STRAIN GAUGE (THE RANGE OF DEFLECTION $X_{max} = 1$ mm, $\varepsilon_{Wmax} = 0.866201$).

Two-current-source bridge 2J+2R	a_d	b_d	$U(a_d)$	$U(b_d)$	$s_{ew} [\%]$
0.5 % dispersion R_0	0.915619	0.152809	0.000075	0.000023	4.12
without dispersion R_0	0.875020	0.174259	0.000017	0.000009	3.13
Wheatstone's bridge	a_w	b_w	$U(a_w)$	$U(b_w)$	$s_{ew} [\%]$
0.5 % dispersion R_0	1.017133	0.090555	0.000133	0.000041	7.59
without dispersion R_0	0.935297	0.124349	0.000032	0.000020	5.00
Anderson's loop	a_p	b_p	$U(a_p)$	$U(b_p)$	$s_{ew} [\%]$
	0.874489	0.578160	0.000060	0.000032	1.71

Note: parameter of the reference (Keithley) model $\hat{\varepsilon}_W = a_{K1}X$ ($a_{K1} = 0.866201$) and average relative estimation error $s_{ew} = 1.16\%$ for $L = 100$, $K = 1$.

where $r(\bar{U}_{AB}', \bar{J})$ – coefficient of correlation between input values \bar{U}_{AB}' and \bar{J} .

During the following stage of calculations, an additional source of uncertainty, resulting from resistance dispersion $R_{10} = R_{20} = R_{30} = R_{40} = R_{r1} = R_{r2} = R_0$ of the bridge, was taken into consideration. The resistance boundary error R_0 was estimated with the total differential method, obtaining $\pm 0.5\%$. Considering a different character of uncertainties $u_c(\bar{\varepsilon}_W')$ (A and B type [13], from the measurements) and $u(R_0)$ (B type, from estimations), they were geometrically added, in compliance with the rule of uncertainty propagation [13]. The approximated combined standard uncertainty value of the resistance relative increment measurement was obtained in this way

$$u_c(\bar{\varepsilon}_W') \approx \sqrt{u_c^2(\bar{\varepsilon}_W') + \left(\frac{\partial \bar{\varepsilon}_W'}{\partial R_0} \right)^2 u^2(R_0)}. \quad (15)$$

In equation (11), the resistance relative increment is the dependent variable. Different measurement uncertainties $u_c(\bar{\varepsilon}_W')$ were obtained for particular $\bar{\varepsilon}_{Wm}$ ($m = 1, 2$ to 11). The uncertainties result from sources of both A and B types. Whereas deflection X is an independent variable.

As uncertainties $u_c(\bar{\varepsilon}_W')$ have different values, the line coefficients (a_u and b_u) were determined with the weighted least squares regression method [11]. Expanded uncertainties $U(a_u)$ and $U(b_u)$, however, were determined taking into account the coverage factor $k = 2$ and the confidence level $p = 95\%$. Additionally, average estimation error (square of residual variance) was calculated for each model (5)–(10)

$$s_e = \sqrt{\frac{\sum_{m=1}^L (\hat{\varepsilon}_{Wm} - \bar{\varepsilon}_{Wm})^2}{L - K}}, \quad (16)$$

where L – number of observation ($L = 11$), K – number of estimated parameters ($K = 2$).

The relative average estimation error was related to the average increment module

$$\bar{\varepsilon}_W = \frac{\sum_{m=1}^L \bar{\varepsilon}_{Wm}}{L} \rightarrow s_{ew} = \frac{s_e}{|\bar{\varepsilon}_W|} \times 100\%. \quad (17)$$

TABLE IV. COMPARISON OF COEFFICIENTS a_u AND b_u OF THE DETERMINED STRAIGHT LINES AND THEIR EXPANDED UNCERTAINTIES (FOR $k = 2$ AND $p = 95\%$) AND AVERAGE RELATIVE ESTIMATION ERRORS FOR CIRCUITS WITH TWO METAL STRAIN GAUGES (THE RANGE OF DEFLECTION $X_{max} = 10$ mm, $\epsilon_{Wmax} = 0.083545$).

Two-current-source bridge 2J+2R	a_d	b_d	$U(a_d)$	$U(b_d)$	s_{ew} [%]
0.5 % dispersion R_0	0.00840671	-0.10963994	0.00000073	0.00000441	0.12
without dispersion R_0	0.00831815	-0.10960964	0.00000012	0.00000065	0.12
Wheatstone's bridge	a_w	b_w	$U(a_w)$	$U(b_w)$	s_{ew} [%]
0.5 % dispersion R_0	0.00882729	0.00260378	0.00000012	0.00000040	0.92
without dispersion R_0	0.00882690	0.00260405	0.00000011	0.00000040	0.92
Anderson's loop	a_p	b_p	$U(a_p)$	$U(b_p)$	s_{ew} [%]
	0.00837743	-0.01357607	0.00000006	0.00000038	0.26

Note: parameter of the reference (Keithley) model $\hat{\epsilon}_W = a_K 2^X$ ($a_{K2} = 0.00835456$) and average relative estimation error $s_{ew} = 3.13\%$ for $L = 100$, $K = 1$.

VIII. MEASUREMENT RESULTS AND ANALYSIS

Estimated parameters a_u and b_u of linear regression models, their expanded uncertainties $U(a_u)$ and $U(b_u)$, as well as average relative estimation errors s_{ew} are given in Table III and Table IV.

Figure 9–Fig. 12 was made on the basis of (12), (13) and Table II, Table III. The differences between particular tested circuits are visible. Except for Wheatstone's half-bridge, offset errors (Fig. 9(b) and Fig. 10(b)) for models without dispersion R_0 are quite big (over 10 %).

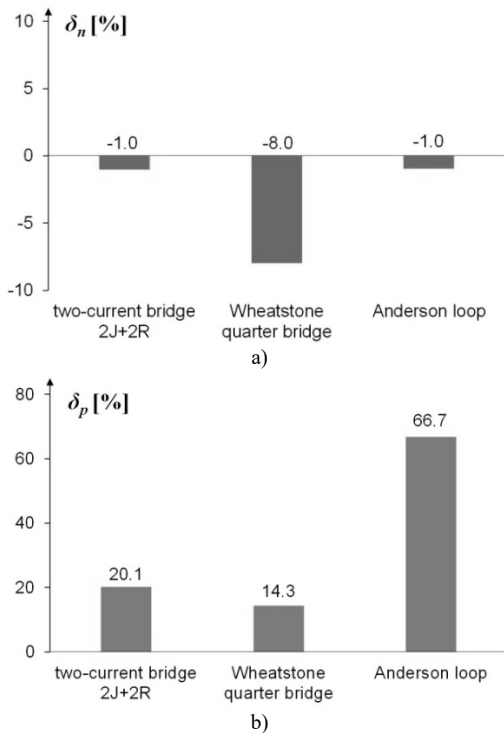

Fig. 9. Gain errors (a) and offset errors (b) for three tested circuits with one semiconductor strain gauge (models without dispersion R_0).

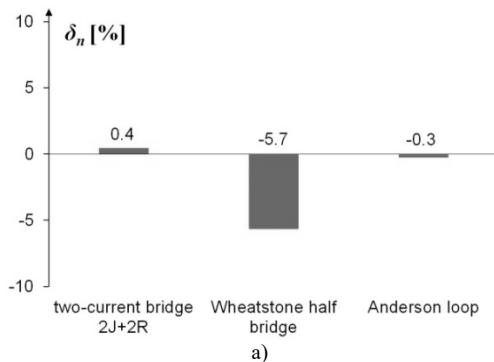

Fig. 10. Gain errors (a) and offset errors (b) for three tested circuits with two metal strain gauges (models without dispersion R_0).

Low resistance increment measurement (up to 1 Ω) is one reason of this situation. It is also worth stressing that in both experiments gain errors for a two-current-source bridge appeared significantly smaller (Fig. 9(a), Fig. 10(a)).

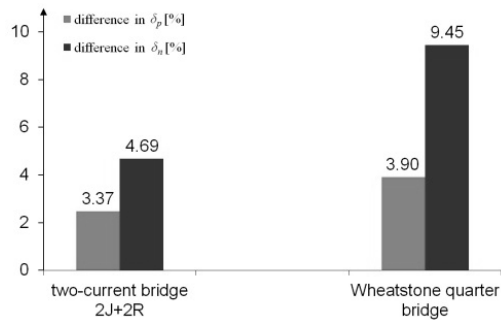

Fig. 11. Offset/gain error change for a two-current-source bridge 2J+2R and a Wheatstone's bridge (with one semiconductor strain gauge) after considering dispersion R_0 as an input quantity affecting the coefficients uncertainty a_u and b_u .

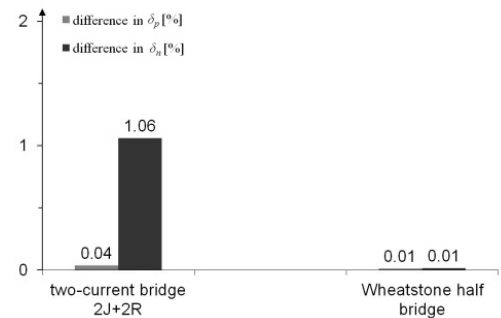

Fig. 12. Offset/gain error change for a two-current-source bridge 2J+2R and a Wheatstone's bridge (with two metal strain gauges) after considering dispersion R_0 as an input quantity affecting the coefficients uncertainty a_u and b_u .

As it can be observed in Fig. 11 and Fig. 12, accepting resistance dispersion R_0 of $\pm 0.5\%$ value affects the change

in both gain and offset errors. Wheatstone's half-bridge with two metal strain gauges appeared to be the least sensitive to the circuits initial resistances dispersion (Fig. 11, Fig. 12).

IX. CONCLUSIONS

The following conclusions and remarks can be formed on the basis of the research results:

For a two-current-source bridge 2J+2R with two metal sensors (Table III), the uncertainty of linear models parameters $\hat{\epsilon}_W = a_u X + b_u$ reach the greatest values. In the case of cooperation with semiconductor sensors (Table II), those parameters reach the greatest values for the Wheatstone's quarter-bridge (model with dispersion R_0).

In the case of circuits with one semiconducting strain gauge (Fig. 9(a)), smaller values of gain error were obtained for the Anderson's loop and 2J+2R bridge than for the Wheatstone's quarter-bridge. The two-current-source bridge 2J+2R appeared to be less sensitive to resistance dispersion R_0 than the classic quarter-bridge (Fig. 11). Moreover, a better adjustment (smaller average estimation error s_{ew}) of the linear model to empirical data from the 2J+2R bridge in relation to data from the Wheatstone's bridge (Table III) was obtained.

In the other experiment (with two metal strain gauges), smaller values of gain error were also obtained for the Anderson's loop and the two-current-source circuit, whereas greater values – for the Wheatstone's half-bridge (Fig. 10(a)). The Wheatstone's half-bridge appeared to be significantly more sensitive to resistance dispersion R_0 than the 2J+2R bridge (Fig. 12).

Resistance R_0 occurrence in measurement equations (5), (6), (8), (9) is a drawback of bridges in relation to Anderson's loop. If the R_0 value is defined imprecisely in a two-current-source bridge, it affects both the gain and the offset error (Fig. 11, Fig. 12).

The interpretation of the results was done without considering the influence of parameters of operational amplifiers on the measurement uncertainty. Identical amplifiers were applied in all three tested circuits. It was accepted that they have the same influence on the circuits input-output characteristics.

The unconventional circuit 2J+2R allows to measure two parameters simultaneously. It can be utile in industry where there is a need to measure mechanical strain and the change of temperature of strain gauges in a specific localization. A

disadvantage is that two current sources in the circuit should provide equal currents.

In the research presented above, the influence of one parameter (mechanical deflection) on the resistance increment of sensors was analysed. Further work will concern a two-current-source bridge application in simultaneous measurements of two parameters, e.g. deflection and temperature.

REFERENCES

- [1] W. Walendziuk, A. Idzkowski, Z. Machacek, Z. Slanina, "Evaluation of Pt100 sensor deflection effect during strain measurements", *Elektronika ir Elektrotechnika*, vol. 21, no. 4, pp. 23–26, 2015. [Online]. Available: <https://doi.org/10.5755/j01.eee.21.4.12776>
- [2] B. Maundy, S. J. G. Gift, "Strain gauge amplifier circuits", *IEEE Trans. Instrumentation and Measurement*, vol. 62, no. 4, pp. 693–700, 2013. [Online]. Available: <http://dx.doi.org/10.1109/TIM.2013.2246904>
- [3] T. Islam, S. A. Khan, S. S. Islam, Harsh, "Sensitivity enhancement of wheatstone bridge circuit for resistance measurement", *Sensors & Transducers Journal*, vol. 6, pp. 96–102, 2009.
- [4] N. A. Gilda, S. Nag, S. Patil, M. S. Baghini, D. K. Sharma, V. R. Rao, "Current excitation method for delta r measurement in piezo-resistive sensors with a 0.3-ppm resolution", *IEEE Trans. Instrumentation and Measurement*, vol. 61, no. 3, pp. 767–774, 2012. [Online]. Available: <http://dx.doi.org/10.1109/TIM.2011.2172118>
- [5] L. Cvitas, Z. Hocenski, "Increasing accuracy of temperature measurement based on adaptive algorithm for microcontroller transmitter", *Tehnicki Vjesnik-Technical Gazette*, vol. 17, no. 4, pp. 445–452, 2010.
- [6] C. Pedersen, S. T. Jespersen, J. P. Krog, C. Christensen, E. V. Thomsen, "Combined differential and static pressure sensor based on a double-bridged structure", *IEEE Sensors Journal*, vol. 5, no. 3, pp. 446–454, 2005. [Online]. Available: <https://doi.org/10.1109/JSEN.2005.845199>
- [7] M. M. S. Anands, *Electronic Instruments and Instrumentation Technology*. Prentice-Hall of India: New Delhi, 2006.
- [8] M. Kreuzer, "Linearity and sensitivity error in the use of single strain gages with voltage-fed and current-fed circuits", Technical literature of Hottinger Baldwin Messtechnik, [Online]. Available: www.hbm.com
- [9] M. Kreuzer, "Wheatstone bridge circuits shows almost no nonlinearity and sensitivity errors when used for single strain gage measurements", Technical literature of Hottinger Baldwin Messtechnik, [Online]. Available: www.hbm.com
- [10] A. D. Cuenca, L. O. Beltran, J. P. Talledo Vilela, J. C. Miranda, "Comparison of microstrain indicators measurements based on Anderson's Loop and Wheatstone Bridge", in *Proc. 16th Int. Conf. Electronics, Communications and Computers (CONIELECOMP 2006)*, 2006.
- [11] T. P. Ryan, *Modern Regression Methods*. Wiley: New York, 1997.
- [12] B. Heimann, W. Gerth, K. Popp, *Mechatronik, Hanser Fachbuchverlag*. Leipzig, 2007. (in German)
- [13] Evaluation of measurement data - Guide to the expression of uncertainty in measurement, First edition, JCGM 100:2008, [Online]. Available: www.bipm.org