

Position Measurement of Oscillating Linear Movement of Mechatronic Device

V. Jankūnas

*Department of Electronics Engineering, Kaunas University of Technology,
Studentų str. 50, LT-51368 Kaunas, Lithuania,
Department of Electrical Engineering, University of Klaipėda,
Bijūnų str. 17, LT-91225 Klaipėda, Lithuania e-mail: zmogas@hotmail.com*

D. Eidukas

*Department of Electronics Engineering, Kaunas University of Technology,
Studentų str. 50, LT-51368 Kaunas, Lithuania, e-mail: danielius.eidukas@ktu.lt*

E. Guseinoviėnė

*Department of Electrical Engineering, University of Klaipėda,
Bijūnų str. 17, LT-91225 Klaipėda, Lithuania, e-mail: guseinoviene@gmail.com*

Introduction

The most important parameters, while researching linear oscillating synchronous electrical mechatronic devices [1], are the curve (curves) of movement of the mover (movers). It is not hard to obtain such curve, while modelling mathematically but it is complicated to measure by doing physical experiment. In this paper the device to measure the curve of movement is proposed and analyzed.

Problem

The object of investigation is the drive of linear oscillating synchronous motor (Fig. 1).

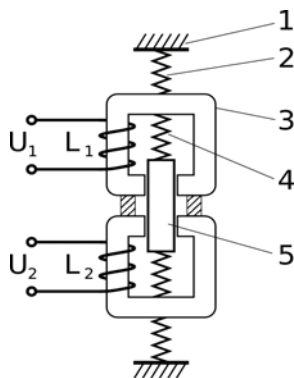

Fig. 1. The drive of oscillating synchronous motor

Mechanic part of the motor is oscillating two-mass system: the stator is mounted to the base with infinite mass by the springs 2 (Fig. 1); by the springs 4 the mover 5 is

attached to the stator which consists from the windings $L1$, $L2$ and cores 3. Stator and mover may move only to the straight (according Fig. 1 – by vertical stroke).

Working principle: if supply voltages U_1 and U_2 are connected respectively to the windings $L1$ and $L2$ alternately, magnetic field is created in cores (Fig. 1, 3) alternately. Under the influence of this field, the mover (Fig.1, 5) is forced to oscillate. At the same time the stator oscillates as well.

While analyzing oscillating mechatronic device, we need to measure curves of movement of both the mover and the stator. To measure it, we need special measure device to be designed since the amplitudes of the mover and the stator are very small.

Method of solving of the problem

On purpose to avoid influence of measurement to the work of the drive, it needs to use contactless position sensors. Induction or Hall-effect sensors cannot be applied since magnetic part of mechatronic system may pervert results of measurement. The best solution is to use optical system of measurement [2] which is used in presented in this article measurement device for measure the curve of movement.

Principle of operation of optical measurement system is presented in Fig. 2. System consists of light source 1 connected with the part of mechatronic device which movement (according axis of abscissas x) is measured and registration camera. It consists of slit 2 and linear image sensor 3 which is a device that converts an optical image to an electric signal. It is worth while slit to use in this system

because registering a few light sources is not necessary to place them in line with direction of movement what is required in optical system using spherical lenses. Besides, imaging system with slit does not require focusing in comparison system with cylindrical or spherical lenses.

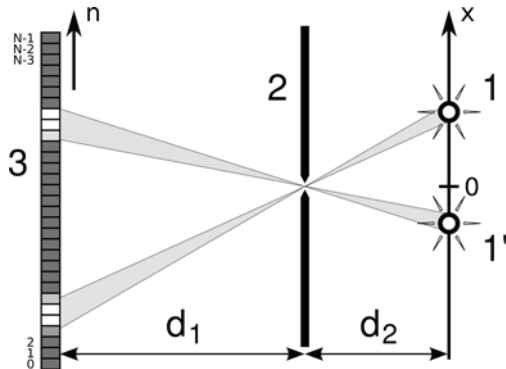

Fig. 2. Operation principle of optical measurement system

View from the light source (Fig. 2, 1) through slit is projected to the optical sensor therefore particular elements of optical sensor register light beam; light source is related with mechatronic device and when it moves also moves light source (Fig. 2, 1') – light beam from this source will be registered by the other elements of optical sensor. So the strip of the illuminated elements of optical sensor may be linked with the position of the light source, and the coordinate of moving part of the mechatronic device may be measured.

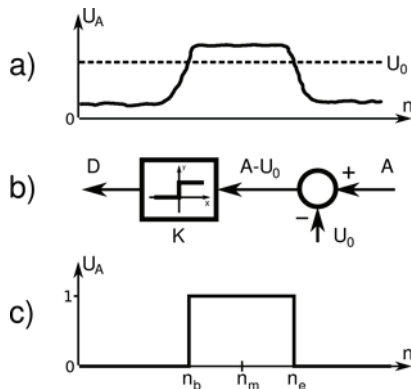

Fig. 3. Process of finding of the coordinate centre of light source projection

In Fig. 3, it may be seen the process of finding of the coordinate of the centre of light source which is projected in the optical sensor. Analogical signal from optical sensor makes a curve, Fig. 3, a): since real light source is not ideal dotted so in the received signal “back” may be seen – it corresponds with the projection of light source. This “back” is separated from the noise by one bit (to aim to calculate faster [3,4]) analogical digital converter (Fig. 3, b): from the analogical signal A which comes from optical sensor the voltage U_0 is subtracted, the difference signal passes to the one bit converter K , where it is obtained a signal which is convenient for the further calculations of Fig. 3, b). The coordinate of the centre of light source,

projected in optical sensor, may be found out according values of coordinates of “back” front n_b and n_e as

$$n = \frac{n_b + n_e}{2}. \quad (1)$$

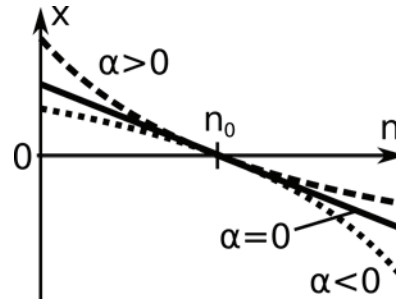

Fig. 4. Transfer functions of imaging system

Transfer characteristics of optical system are shown in Fig. 4. The form of characteristic depends on how parallel axes of movement of mechatronic device and optical sensor are, Fig. 2: if they are parallel, transfer characteristic is linear, otherwise (not a parallel case is definable by anticlockwise angle between axes mentioned above) function is nonlinear. In case of linear function, a coordinate of the point of the curve of movement may be calculated as being

$$x = k(n - n_0) \pm \Delta_x, \quad (2)$$

here n_0 – central coordinate which is found when moving part of measuring mechatronic device is in steady state; x – coordinate of mover; k – scale coefficient calculated according to the ratio of the distance from light source to slit d_2 (Fig. 2) with the distance between slit and optical sensor d_1 ; or according proportion between displacement of mover x_k and corresponding displacement of the projection of the light source in optical sensor $n_0 - n_k$, by

$$k = -\frac{d_2}{d_1} = \frac{x_k}{n_0 - n_k}, \quad (3)$$

$$\Delta_x = k \frac{\rho}{2}, \quad (4)$$

here Δ_x – error which is proportional to the length ρ of one element of optical sensor.

In case of not a parallel axes, coordinate is calculated by

$$x = \frac{d_2 \cos \alpha}{d_1 - \sin \alpha} + \Delta_x, \quad (5)$$

here Δ_x – error which depends on the height of the light source h and maximum deviation x_{max} of measuring point (for positive and negative values separately):

$$\Delta_x = \frac{d_2 \cos \alpha}{-\frac{d_1}{n_m - n_0} - \sin \alpha}, \quad (6)$$

$$n_m = \frac{1}{2} \left(\frac{d_1}{\frac{d_2}{x_{max} - \frac{h}{2}} \cos \alpha + \sin \alpha} - \frac{d_1}{\frac{d_2}{x_{max} + \frac{h}{2}} \cos \alpha + \sin \alpha} \right) \pm \frac{\rho}{2}. \quad (7)$$

Duration of image fixation (exposition) is important for accuracy of measurement of the coordinate. It has to be as little as possible and image of the light source has to be as little blurred as possible as well. Certainly, if exposition term will be the same as duration of oscillating period of the mover of the mechatronic device, it is possible to measure the amplitude of oscillations. Exposition may be realized when in optical way of measurement system a mechanical shutter is to be set. Nevertheless, the simplest and easiest way is to modulate the duration and moment of the light source.

To measure the curve of movement at the transient process a measurement device of coordinate has to be able to measure enough coordinates N of swing of mover by the time grid step t_g , to form the curve of movement of Fig. 5, a).

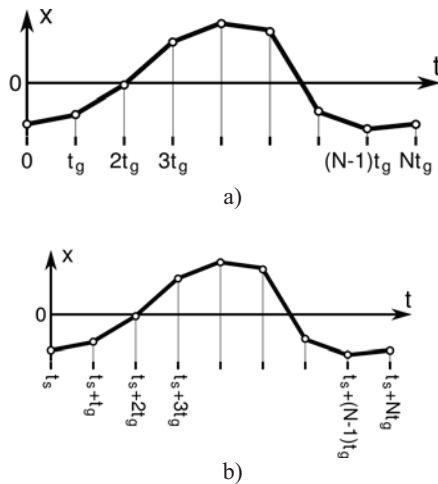

Fig. 5. Formation of the curve of movement

If device is slower, it has to measure coordinates of mover at the moments oriented to the moment when synchronization signal is received, Fig. 5, b). Synchronization signal is received from energy source supplying analyzing mechatronic device. In that case when synchronization is performed according to the beginning of the period of supply voltage of one of the windings, the curve of the movement may be measured only at steady state.

To measure the curves of movement of the two points of analyzing device, coordinate measuring device has to be constructed. In that case, it is recommended to use linear optical sensor which has a few lines of elements sensitive to the different part of light spectrum. In such a device every line could register only coordinate of marked color of mechatronic device of Fig. 6.

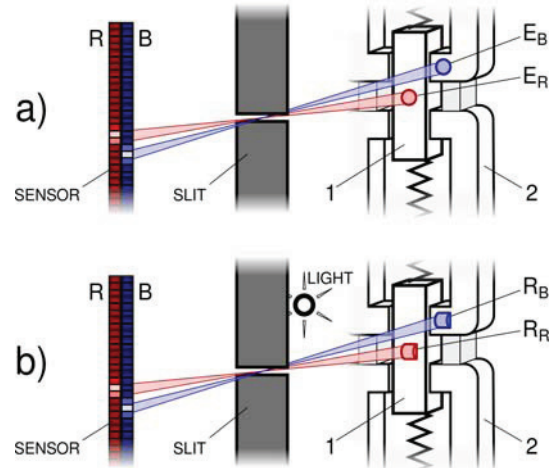

Fig. 6. Measurement of coordinates of several points

Let us look to the moving part of mechatronic device with red color LED, E_R of Fig. 6, a) attached as well as of blue color LED, E_B of Fig. 6, b) attached. Attached LED of red color will be registered in optical sensor only by line sensitive to the red color. The blue LED, Fig. 6, E_B will be registered only by line sensitive to the blue color. This decision allows to attach LEDs to the parts of mechatronic device instead of LEDs of corresponding color of reflected surface and to illuminate them by light source of white color of Fig. 6, b).

Practical implementation

Fig. 7 gives a principal scheme of the real device capable to measure the curves of movement.

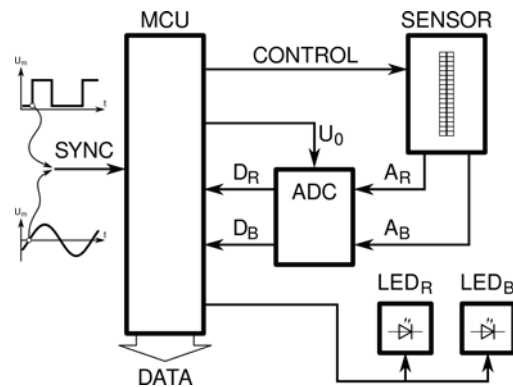

Fig. 7. Principal scheme of the device to measure the curves of movement

A microcontroller MCU registers synchronosignal SYNC which passes from energy source supplying mechatronic device. At the certain moment for particular time, a red

LED_R and blue LED_B are switched on (they are attached to the mover of analyzing mechatronic device and to the stator respectively). After that, at the sending moment of the control command, CONTROL RGB LEDs, analogical signals A_R and A_G are obtained in the sensor (they correspond an image stated by LEDs). These signals are converted by analogical-digital converters, ADC are analyzed by microcontroller to detecting of coordinates of LEDs, and calculating of coordinates of the moving parts of mechatronic device. Data of measured curves of movement are being sent to the personal computer for storage and analyzing.

Such data of measured curves of movement may be transmitted to the supply source of mechatronic device, and may be used to producing closed automatic control system.

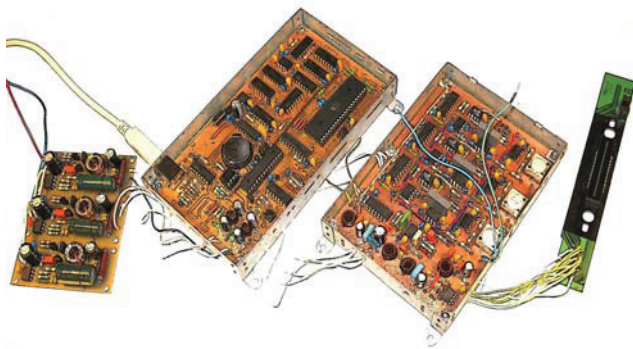

Fig. 8. Photo of real measurement system

Photo of prototype device is shown in Fig. 8. From the left to the right we see: supply source, digital block (microcontroller for the curve of movement, block of interchangeable memory, and microcontroller for the link with personal computer), block of analogical-digital converters, and optical sensor without slit.

Conclusions

1. For analyzing of movement of the parts of mechatronic device, it is recommended to use optical sensors. Such an approach may reduce of mechanical influence to the work of mechatronic device also influence of magnetic circuit to the results of measurement may be eliminated.

2. For realizing of exposition of picture, it is recommended to control radiance of the registered LEDs. It allows obtaining higher-speed in comparison with mechanical shutter and higher accuracy of measurement.

3. It is advisable to use slit in optical system. This allows not using focusing of optical system, and light sources may be situated without limits.

4. Presented measurement system is applied only in linear oscillating mechatronic devices of linear oscillations.

References

1. **Jankūnas V., Guseinoviėnė E., Urmonienė L.** Adequacy of Mathematical and Physical Model of Oscillating Mechatronic Device // *Electronics and Electrical Engineering*. – Kaunas: Technologija, 2008. – No. 7(87). – P. 69–72.
2. **Prosevičius T., Raudonis V., Kairys A., Lipnickas A., Simutis R.** Autoassociative Gaze Tracking System based on Artificial Intelligence // *Electronics and Electrical Engineering*. – Kaunas: Technologija, 2010. – No. 5(101). – P. 67–72.
3. **Brazaitis A., Guseinoviėnė E.** Control of Activators of Mechatronic Devices by Real Time Information Transfer // *Kaunas Technologija*, 2009. – No. 2(90). – P. 89–94.
4. **Brazaitis A., Guseinoviėnė E., Jankūnas V.** Control of Oscillation Amplitude of Oscillating Motors // *Electronics and Electrical Engineering*. – Kaunas: Technologija, 2010. – No. 3(99). – P. 77–82.

Received 2011 01 17

V. Jankūnas, D. Eidukas, E. Guseinoviėnė. Position Measurement of Oscillating Linear Movement of Mechatronic Device // *Electronics and Electrical Engineering*. – Kaunas: Technologija, 2011. – No. 3(109). – P. 7–10.

The problem of measurement of the curve of movement of oscillating synchronous electric devices is discussed. To achieve the purpose system, the light emitting diode (LED) – slit – linear optical sensor is used. Different color LEDs are linked with different moving parts and optical sensor with the lines of the elements sensitive to different colors, are used to simplify measurement system. Practical implementation of measurement system is presented. Ill. 8, bibl. 4 (in English; abstracts in English and Lithuanian).

V. Jankūnas, D. Eidukas, E. Guseinoviėnė. Tiesiaėigio švytuojamojo mechatroninio įtaiso koordinatės matavimas // *Elektronika ir elektrotechnika*. – Kaunas: Technologija, 2011. – Nr. 3(109). – P. 7–10.

Sprendžiama mechatroninių švytuojamųjų sinchroninių elektros įtaisų judančiųjų dalių judesio kreivės matavimo problema. Tikslui pasiekti naudojama šviestuko – plyšinės blendos – tiesinio optinio jutiklio sistema. Matavimo sistemai supaprastinti naudojami skirtingų spalvų šviestukai, susieti su skirtingomis judančiomis dalimis, bei optinis jutiklis su skirtingoms spalvoms jautrių elementų eilėmis. Parodoma, kaip matavimo sistema įgyvendinama praktikoje. Il. 8, bibl. 4 (anglų kalba; santraukos anglų ir lietuvių k.).