

Electronic Plant Leaf Testing System

E. Keras, P. Balaišis, N. Dzingus, D. Eidukas, A. Valinevičius

*Department of Electronics Engineering, Kaunas University of Technology,
 Studentų st. 50, LT-51368, Kaunas, Lithuania, phone: +370 37 300520, e-mail: eugkera@stud.ktu.lt*

Introduction

Many biotronic systems (BTS) [1], including phytotronic systems (FTS) [2] are being improved and become integrated ones [3], for example IFTS that consists of a few biological and electronic systems (BS and ES). The example of such system is showed in the Fig. 1.

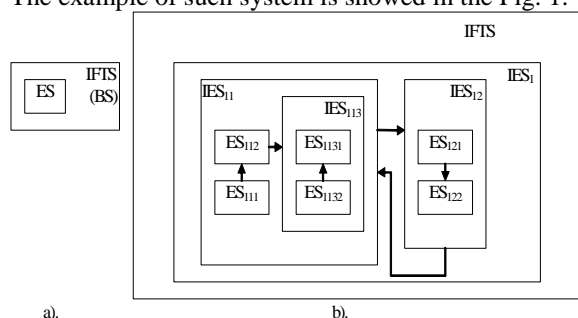

Fig. 1 IFTS structure

By creating IFTS, attempts are made to form an accurate priority of BS (for example phytosystem (FS)) [4–9], so (Fig. 1, a) is dependent on BS and together they form IFTS. This is shown in details in Fig. 1, b. Here ES becomes an integrated system (IES)-IES₁, consisting of two integrated (analysis and decisions) systems (IES₁₁ or IES₁₂). Analysis system consists of detection management system (IES₁₁₁), data analysis system (IES₁₁₂) and integrated evaluation system (IES₁₁₃). IES₁₁₃ consists of evaluation of procedures management system (IES₁₁₃₁) and normative base management system (IES₁₁₃₂). Integrated decision management system IES₁₂ consists of management technologies formation systems (IES₁₂₁) and decisions implementation procedures management system (IES₁₂₂). IES₁₂ is influencing the management of biological object (BO), through the IES₁₁ it is managing IES₁₁₁, IES₁₁₂ and IES₁₁₃ as well. When the phytotron management system is integrated in such way, IES₁₁₁ could become electronic plant leaf testing system (ELTS). In such situation the structure of ES₁₂₂, that became an integrated system (IES₁₂₂), could be similar to the one presented in Fig. 2.

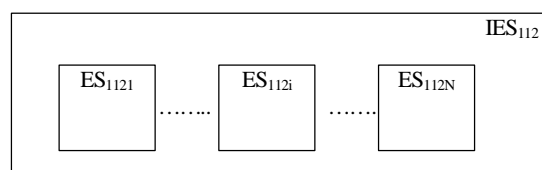

Fig. 2 Possible IES₁₂₂ structure

Here, for example, IES₁₂₂₁ is an electronic artificial vapour level management system, and IES_{122i} – electronic fertilization management system, IES_{122N} – phytotron temperature management system.

Let's analyze the ELTS formation possibilities.

ELTS operation algorithm

The main task of ELTS is to define the condition of BO, the additional tasks are: to collect information and to use it (as supplementary) in the future, to gain experience and to improve the management of IES₁₁₁, IES₁₁₂ or IES₁₁₃. ELTS operation algorithm is presented in the Fig. 3.

In the algorithm scheme the dotted line shows what systems (defined in the Fig. 1) (IES₁₁₁, IES₁₁₂, IES₁₁₃₁, IES₁₁₃₂ and IES₁₁₃ (integrating its parts)) involve the procedures. The rest of the systems that are not incorporated by dotted line are attributed to IES₁₁.

This algorithm shows that one of the first IES₁₁₁ formation procedures is BO condition features search, investigation and choice. The features group consists of forward (formed before the condition) and existing condition features descriptions. They all match ELTS, but the first ones create the possibilities to forecast future conditions and, if there is a need, to avoid them.

When the features are known it is possible to choose their indicator values. To make it easier to understand how it works let's examine one (of some possible) generalised ELTS structure together with this algorithm (Fig. 4). BO (for example plant leaf) is chosen for testing. It is scanned with scanning system (see Fig. 4) that is managed from IES₁₂ through IES₁₁ (Fig. 1) and additionally from IES₁₁₃ (Fig. 4).

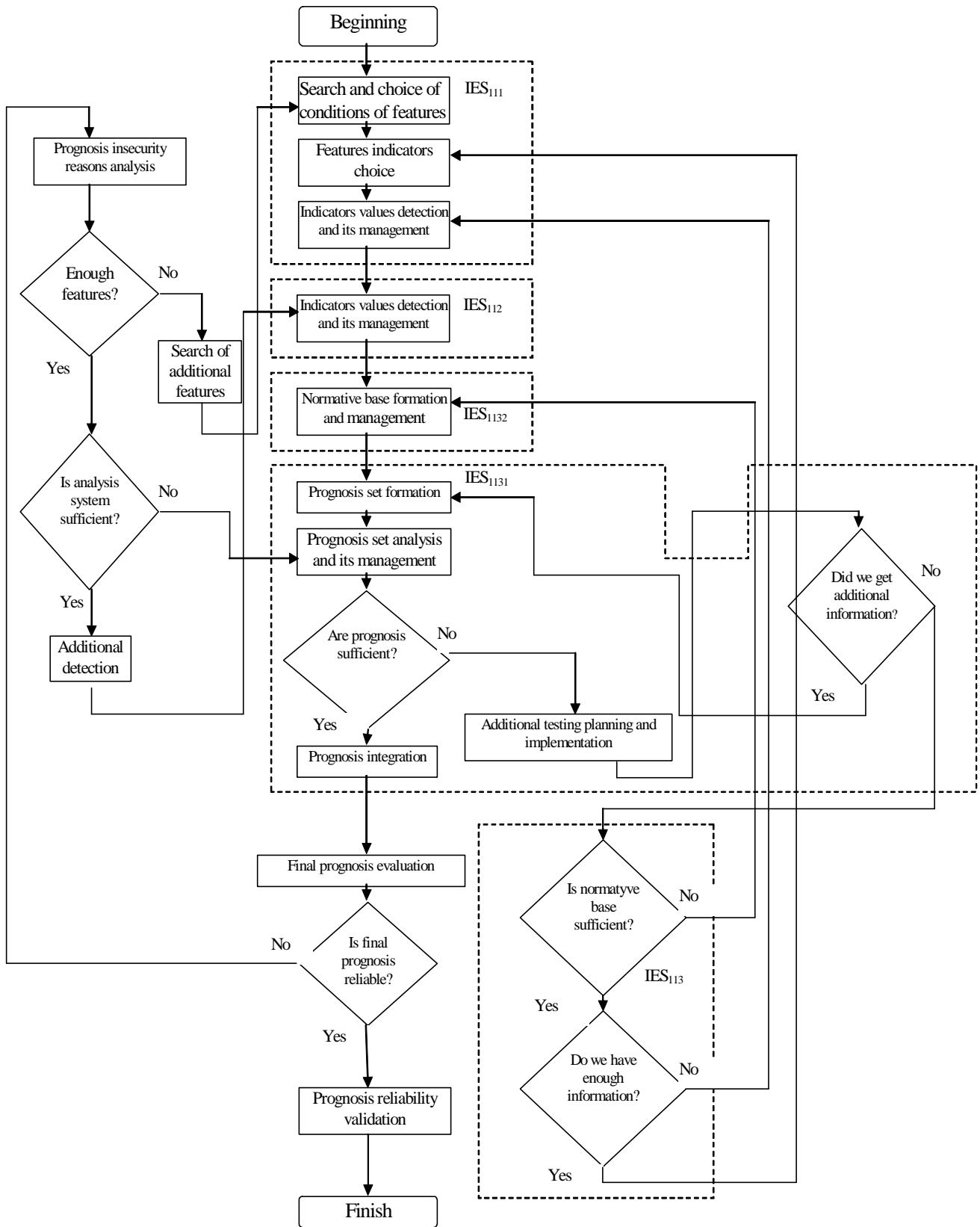

Fig. 3. ELTS operation algorithm

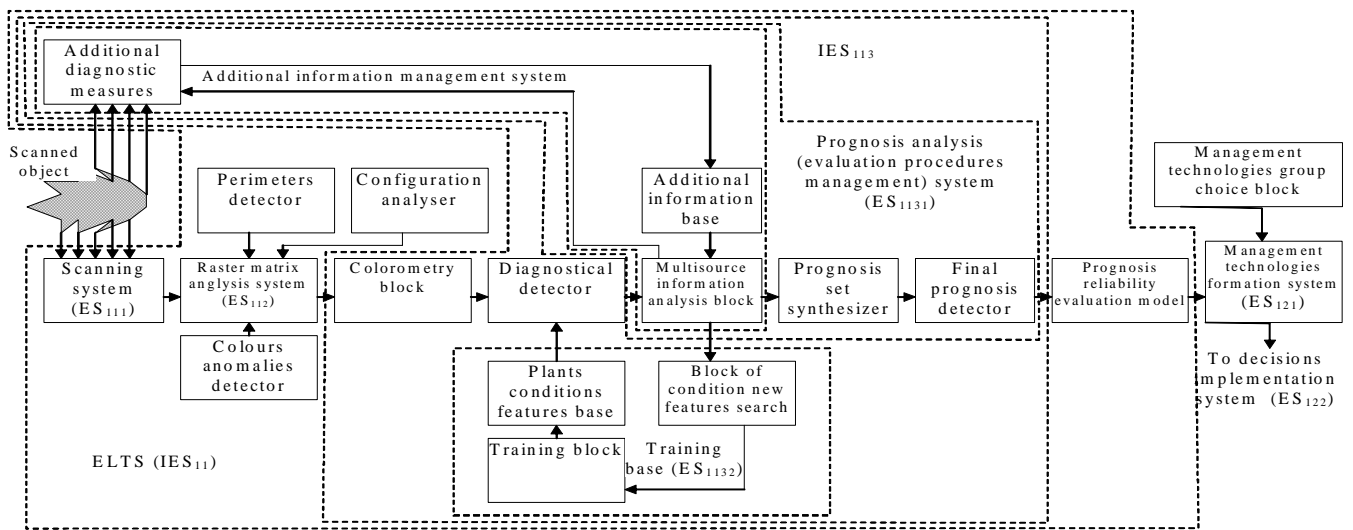

Fig. 4 ELTS structure and interfaces with environment

The results of scanning are systemized and one or a few raster matrixes are created, they become the objects of indicators' values initial analysis. IES₁₁₂ does it. In this stage the detection of leaf and its separate areas parameters is performed, the configuration analysis is done, colour anomalies are detected and other raster matrix data tests are performed. The tests data are forwarded to IES₁₁₃, where the colorimetric measurements are done first (the separate raster matrix elements colours wave lengths are measured and calculated). The common leaf colour scale is formed and the waves' length differential capacity is calculated, the anomaly zones parameters are found out. All these tests can be repeated for many analogical scanning objects and finally are passed to the diagnostic detector which task is using raster analysis results and plant conditions' features bases data to prepare possible interim and (or) forecasted existing conditions alternatives by defining their possible reliability. These data are passed to IES₁₁₃₁ (Fig. 4) to the multisource information analysis block. The purpose of this block: finally accept or decline the presented prognosis.

The prognoses that are not reliable enough are tested additionally by using supplementary diagnostic measurements and forming the additional information base (see the additional information management system in Fig. 4). By working with prognoses and additional information together the BO conditions' new features search is performed and the results are presented to the training block (See ES₁₁₃₂ in Fig. 4). That helps to improve conditions' features base. The new features are introduced to the diagnostic detector through this interface and they go to the multisource information analysis block and finally to the additional diagnostic measures. In the testing results the reliable prognosis set is formed, and the next stage is final prognosis detection. In this stage of the process the reliability of all prognoses is considered and one final (most demonstrative) prognosis is distinguished, or a few reliable prognoses set. After this process IES₁₁ performs final prognosis evaluation (see Figure 3) and if it is reliable it is confirmed by transferring the data to the management technologies formation system (ES₁₂₁ in Fig. 4), which considering the chosen management technologies group

(directive, prioritized or freely synthesized) and use them or create. When there is no possibility to confirm final appreciated prognosis reliability the additional features search and analysis are being improved. Prognosis confirming or declining reasons describing data are transferred to the training block and finally to the diagnostic detector and multisource information analysis block.

Technical measures and their technologies

The main technical ELTS measures are presented in the Fig. 5.

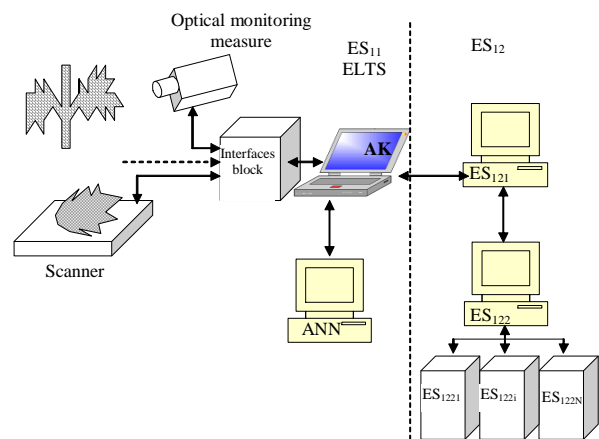

Fig. 5 Main technical ELTS measures (AK – personal computer, ANN – artificial neurons nets)

This is a general ELTS structure. Further creating this system it is necessary to design the operation technologies for every component. These component technologies are among the most important ones:

- Leaf perimeter detector;
- Configurations analyser;
- Colour anomalies detector;
- Colorimetric block;
- Diagnostic detector;

- Multisource information analysis block;
- Additional information management systems;
- Training bases;
- Final prognosis detector and others.

These are the further ELTS modeling directions [5–9].

Conclusions

By testing BO conditions in a complex way it is possible to create an integral prognoses system. One of the main information sources (for this system) in phytotronics could be the plant leaf. After performing a many sided plant size, form, perimeter, colour scale and other tests it is possible to form the prognoses set, to evaluate the reliability of these prognoses and to detect the final prognosis that will be used in organising FTS management and stand as priority in FS objectives choice. That would separate FTS from every other FS and ES interaction (interface).

ELTS efficiency depends on its usage intensity, automation level, prognoses reliability and some other factors. Therefore it is very important to form the operation technologies for single ELTS components.

References

1. **Bagdanavičius N., Balaišis P., Eidukas D., Keras E., Valinevičius A.** Features of Biotronics systems // *Electronics and Electrical Engineering*. – Kaunas, 2006. – No. 8(72). – P. 55–60.
2. **Valinevičius A., Balaišis P., Eidukas D., Bagdanavičius N., Keras E.** Biotronic System Network Efficiency Investigation // *Electronics and Electrical Engineering*. – Kaunas, 2006. – No. 3(67). – P. 13–18.
3. **Eidukas D., Balaišis P., Valinevičius A., Žilyš M.** Reliability and Efficiency of Electronics Systems. – Kaunas: Technologija, 2006. – 316 p.
4. **Balaišis P., Keras E., Valinevičius A.** Control efficiency of Persistence of Biotronics Networks // *Electronics and Electrical Engineering*. – Kaunas, 2008. – No. 7(87). – P. 31–36.
5. **Balaišis P., Valinevičius A., Keras E.** Analysis of BTS Research Directions // *Biosystems Engineering and Processes in Agriculture*: Kaunas: Academia Scientiarum Lithuaniae. – 2008. – No. 13. – P. 130–134.
6. **Choi S. K., Grandhi R. V., Canfield R. A.** Reliability-based Structural Design. ISBN-10: 1-84628-444-9. Springer, 2006. – 306 p.
7. **Dekeris B., Gudonavičius R., Narbutaitė L.** Telekomunikacijų tinklo būklės įvertinimo modelis // *Elektronika ir elektrotechnika*. ISSN 1392-1215. Kaunas: Technologija, 1997. – Nr.2(11). – P.18-21.
8. **Gečys S.** Elektros įrenginių patikimumas ir eksploatacija. – Kaunas: Technologija, 2005. – 137 p.
9. **Eidukas D., Kalnius R., Vaišvila A.** Probability Distribution Transformation in Continuous Information Systems Control // ITI 2007: proceedings of the 29th international conference on Information Technology Interfaces, June 25-28, 2007, Dubrovnik, Croatia / University of Zagreb. University Computing Centre. Zagreb : University of Zagreb, 2007. ISBN 978-953-7138-09-7. p. 609-614.

Received 2008 10 10

E. Keras, P. Balaišis, N. Dzingus, D. Eidukas, A. Valinevičius. Electronic Plant Leaf Testing System // Electronics and Electrical Engineering. – Kaunas: Technologija, 2008. – No. 8(88). – P. 99–102.

The integrated phytotronic system (IFTS) structure is formed of biological system (BS) (in this case phytosystem (FS)) and electronic systems. The main peculiarity of these systems integration is that the main goal is chosen (BS) (FS) goal, and ES functions in such way that the most optimal FS goal would be achieved. There is the IFTS used integrated ES (IES) structure proposed, a part of it consists of electronic plant leaf testing system (ELTS), involving the peculiarities detection and reliability evaluation. There is the ELTS operation algorithm proposed. The block ELTS structure is presented. One of possible ELTS technical composition variant is proposed. Technologies testing directions used in ELTS components are highlighted and presented. III. 5, bibl. 9 (English, summaries in English, Russian and Lithuanian).

Е. Керас, П. Балайшис, Н. Дзингус, Д. Эйдукас, А. Валинявичюс. Электронная система для исследования листьев растений // Электроника и электротехника. – Каунас: Технология, 2008. – № 8(88). – С. 99–102.

Из биологической системы (БС) (в данном случае фитосистемы (ФС)) и электронных систем (ЭС) составлена структура интегрированной системы фитотроники (ИСФТ). Основная особенность этих систем заключается в том, что главной целью выбирается цель БС (ФС), а ЭС функционирует так, чтобы была достигнута цель ФС. Предложена структура в ИСФТ применяемой интегрированной ЭС (ИЭС), часть которой составляет электронная система исследования листа (ЭСИЛ) растения, охватывающая детекцию его особенностей, составление растровой матрицы, ее анализ, синтезирование множества прогнозов, детекцию окончательного прогноза, а также оценку надежности этого прогноза. Предложен алгоритм функционирования ЭСИЛ. Предлагается один из возможных вариантов технического состава ЭСИЛ. Акцентируются и приводятся направления исследований технологий, используемых в компонентах ЭСИЛ. Ил. 5, библи. 9 (на английском языке; рефераты на английском, русском и литовском яз.).

E. Keras, P. Balaišis, N. Dzingus, D. Eidukas, A. Valinevičius. Elektroninė augalo lapo tyrimo sistema // Elektronika ir elektrotechnika. – Kaunas: Technologija, 2008. – Nr. 8(88). – P. 99–102.

Iš biologinės sistemos (BS) (šiuo atveju – fitosistemos (FS)) ir elektroninių sistemų (ES) sudaryta integruotos fitotronikos sistemos (IFTS) struktūra. Pagrindinis šių sistemų integravimo ypatumas yra tai, kad svarbiausiu tikslu laikomas BS (FS) tikslas, o ES veikia taip, kad būtų pasiektas kuo optimaliausias FS tikslas. Pasiūlyta IFTS naudojamos integruotos ES (IES) struktūra, kurios dalį sudaro elektroninė augalo lapo tyrimo sistema (ELTS), apimanti jo ypatumų detekciją ir jos patikimumo įvertinimą. Pasiūlytas ELTS veikimo algoritmas. Pateikta blokinė ELTS struktūra. Siūlomas vienas iš galimų ELTS techninės sudėties variantų. Akcentuojamos ir pateikiamos ELTS komponentuose naudojamų technologijų tyrimų kryptys. II. 5, bibl. 9 (anglų kalba; santraukos anglų, rusų ir lietuvių k.).

DOI: 10.5755/j02.eie.11362