

Control of Wind Turbine's Load in order to maximize the Energy Output

V. Adomavičius

*The Centre for Renewables Energy Technologies, Kaunas University of Technology,
Studentų str. 48-329, LT-51367 Kaunas, Lithuania, phone: +370 37 351181; e-mail: vytautas.adomavicius@ktu.lt*

Č. Ramonas, V. Kepalas

*Department of Control Technology, Kaunas University of Technology,
Studentų str. 48, LT-51367 Kaunas, Lithuania, phone: +370 37 300274, e-mail: ceslovas.ramonas@ktu.lt,
vytautas.kepalas@ktu.lt*

Introduction

Large amounts of heat energy are being used in industry and households for heating of premises and domestic hot water preparation as well as for implementation of various technological processes.

Presently the most advanced renewable energy technologies for water heating are based on usage of solar heat, wind, biomass (mostly firewood and wood residues) and heat pumps. Usage of wind energy for this purpose meanwhile is extremely rare exception but in case of skyrocketing crude oil and natural gas prices this technology is becoming economically competitive in windy localities on comparison with traditional technologies based on oil products, natural gas, electricity and centralized heat energy supply from CHP plants.

Wind-based water or space heating systems have two significant advantages:

- 1) heat production does not require any fuel,
- 2) heat energy is being produced without any pollution of the environment.

The main imperfection of this technology is the instability of the wind velocity. Usually the wind velocity is constantly alternating in the wide range, especially in the regions remoted from the sea. Sometimes the wind is too weak for the rotation of wind turbine (WT) or the wind even does not exist. Therefore production of electricity and its conversion into the heat energy is restricted in these cases. However, this problem can be solved by the choosing and installation of the heat energy storage tanks of sufficient volume. The heat energy accumulated in the storage tank can be used when the wind velocity is not sufficient for electricity production by the WT.

Water heating system based on the wind energy is described in this paper. Wind energy there is converted

into the heat energy by means of wind turbine and electrical element for water heating.

It is shown that in order to utilize maximum amount of wind energy available for the choosed WT the load of generator should be automatically controlled depending on the wind velocity. The scheme of the wind-based water heating system is presented and described.

Reasoning of the WT's output control

When the electric power produced by wind turbine is used for water heating, generator of WT is loaded by the heating element. If capacity of the heating element is chosen accordingly to rated capacity of the WT and is being kept constant, rotor of the wind turbine does not rotate when wind velocity is significantly lower on comparison to the rated value for the installed WT. In this case the torque developed by the wind rotor is less than the torque created by WT's generator, which is loaded by the rated resistance. The wind rotor can not rotate and therefore a wide range of wind velocity, which has a high probability of appearance, can not be utilized for the electricity (and heat) production.

If the load resistance of WT's generator is adjusted to the winds of lower velocities and is being kept constant, then the rotational speed of wind rotor at strong winds becomes very high because it is underloaded. Therefore the generator does not develop its maximal capacity at this wind velocity due to the unadjusted load resistance.

As it is shown in Fig. 1, for the every wind velocity v_i the wind turbine has a particular power dependence on the wind rotor's rotational speed $P_i = f(n)$.

When the wind velocity v_i is constant, the position of the WT's operating point on the power curve $P = f(n)$ depends on the torque of the wind rotor's (generator's) load. If the torque of load is minimal, the wind rotor will rotate with maximal speed n_{max} . This operating regime is

inadmissible on purpose to avoid damages of the wind rotor. When the torque of load (load resistance of the WT's generator) is optimal, the WT will take over the maximum of the wind power P_{\max} at this wind velocity v_i . If the torque of load will be increased further, the rotational speed of the wind rotor will decrease and at a certain value of the torque the WT will be stopped.

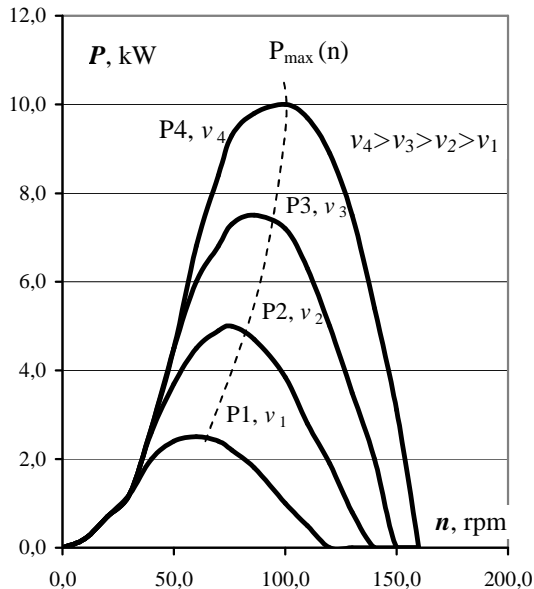

Fig. 1. Dependences of the WT power on the rotational speed of wind rotor (generator) $P = f(n)$ at different wind velocities

Therefore the load resistance of generator must be automatically controlled dependently on the wind velocity on purpose to harvest the power, which is maximum available for the chosen wind turbine.

Some methods for the adjustment of wind turbine's load dependently on the wind velocity are known. For example, in a number of cases Danish-made WTs have installed in the nacelle two generators of different capacity: the smaller one is used at the low wind velocities and the large one – at the sufficiently strong winds [1].

Load control in the wind-based water or air heating systems dependently on the wind velocity can be also realised by means of a simple measure: a number of electric heating elements (for example, 2, 3 or 4) can be commutated using well-known circuitry with contactors. However this way of WT's load control has some imperfections:

- the load control is stepped and therefore is not accurate,
- more electric heating elements (or one specially manufactured element with derivations) are necessary,
- some losses of energy are inevitable due to the stepped nature of the load control,
- no possibility to utilize the surplus of electricity when the heat storage tank is fully charged.

All these imperfections allow solving the described problem only partially. Therefore more advanced and

efficient ways should be found and researched in order to maximize the energy output of WT.

Concept of the WT's power output control

One of the possible ways for implantation of the automatic WT's load control can be realized by using equipment of power electronics. The main load for the WT in the wind-based water heating system is one heating element of rated capacity, which is used in the heat storage tank. On purpose to make the system more cost-efficient, it would be reasonable to have a possibility of supplying the surplus of electricity into the electric grid in cases when the heat storage tank is fully charged. Similar wind-based energy systems for the water and space heating are described in papers [2, 3].

Concept of the proposed wind-based water heating system can be explained by means of the functional electrical scheme of this system, which is presented in Fig. 2. The system consist of the wind turbine WT with generator G, the rectifier AC/DC, the electronic pulse-width modulator of the rectified voltage P-WM, the load control unit LC, the heating element HE, the heat storage tank for the hot water, anemometer A, tachogenerator TG and sensor of temperature T.

Heat storage tanks usually are characterized as having considerable inertia. Therefore the two-step controllers can be applied for them. When the heat storage tank is fully charged, the controller must to switch out the power supply into the heat element and to switch on the WT's power supply to the electric grid over the inverter.

The control unit LC controls the load according to the signals, which are proportional to the wind velocity v_w and rotational speed of WT's generator ω_g . Sensor of temperature T gives for the controller a signal, which is proportional to the water temperature.

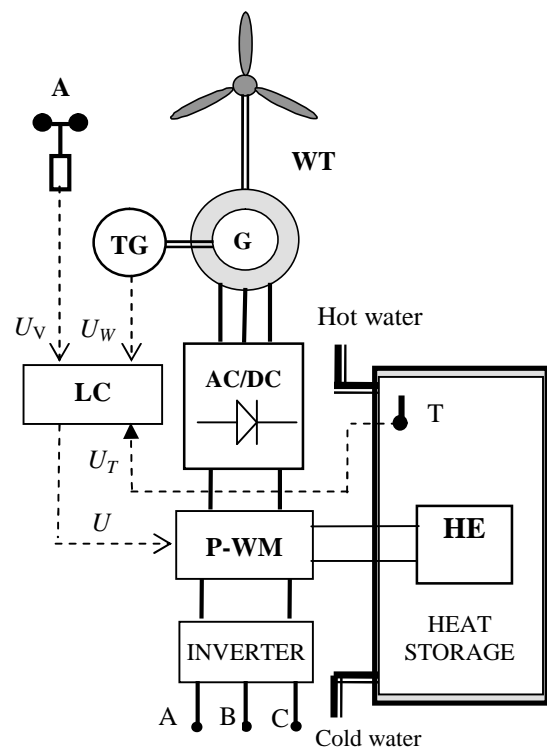

Fig. 2. Wind-based water heating system

The two-step controller of the water temperature in heat storage tank can also be used to switch the WT's generator for power supplying into the electric grid and in contrary – for power supplying into the heat element when it will be necessary.

Mathematical description and model of the WT's load control system

The pulse-width modulator (P-WM) is used for the load control of permanent magnet synchronous generator (PMSG) installed in the WT. Exact description of the electromagnetic processes of the converter's power circuits is rather sophisticated task. Therefore some simplifications [4, 5] used in theory of converters' circuits and facilitating the derivation of mathematical dependences will be applied. The n -phase circuits of converter will be substituted by one-phase reciprocal schemes. Power valves will be considered as ideal.

Intensity of PMSG electromagnetic processes depends on the stator circuit's constant of time (T), which mostly has value more than 0.1 s. In this case the transient processes are going rather slowly, therefore the average values of currents and voltages can be used for the description of these processes and non-stationary processes of the electromagnetic field alternations can be neglected [6, 7, 8]. When the processes are more fast-moving ($T \leq 0.01s$), instantaneous values of current and voltage must be used.

Principle electrical scheme of the PMSG power circuit is presented below in Fig. 3.

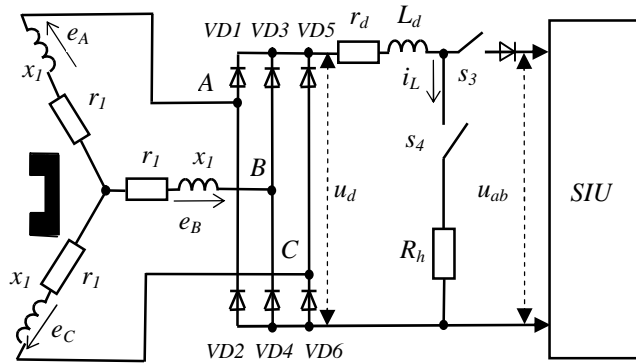

Fig. 3. Principle electrical scheme of the PMSG power circuit

The following lettering is used in Fig. 3: e_a, e_b, e_c – electromotive forces of the generator in the phases A, B and C; u_d – the rectified voltage of the generator; r_1 – the active resistance of the generator's stator winding; x_L – the inductive reactance of generator's stator winding; r_d and L_d – the active resistance and inductance of the rectifying choke; R_h – the active resistance of the heating unit.

The electromagnetic processes taking place in the electrical circuits showed in Fig. 3 when load of the rectifier is the active resistance and inductance are well researched. The rectified electromotive force of the generator can be expressed by using the formula given in source [9]:

$$e_{g0} = \frac{2\sqrt{2} \cdot m}{\pi} U_{f0} \cdot \sin \frac{2 \cdot \pi}{m} \cdot \sin \frac{\pi}{m}. \quad (1)$$

Generator's voltage of one phase can be expressed by means of this dependence:

$$U_{f0} = \frac{k_e \cdot \omega_g}{\sqrt{3}}. \quad (2)$$

Alternative current of the generator's phase depends on the rectified current and the angle of commutation

$$I_f = i_L \cdot \sqrt{\frac{2}{3} - \frac{\gamma}{3 \cdot \pi}}. \quad (3)$$

The angle of the diodes' commutation γ can be calculated by using this formula:

$$\gamma = \arccos \left(1 - \frac{\sqrt{2} \cdot x_K \cdot i_L}{U_l} \right). \quad (4)$$

Voltage drop due to the commutation of rectifier's diodes can be described by the following expression:

$$u_K = \frac{m}{2 \cdot \pi} \cdot x_K \cdot i_L. \quad (5)$$

The following symbols are used in formulas (1–5): U_{f0} – open circuit effective phase voltage of the generator; m – the number of pulsations of the rectified voltage; U_l – the effective linear voltage of the generator; k_e – factor of the generator's electromotive force; ω_g – the rotational speed of the generator; i_L – the rectified current; γ – the angle of the diodes' commutation.

For the evaluating calculations it can be admitted that $x_K \approx x_L$ (x_L – the inductive reactance of generator's stator winding).

One-line scheme of wind turbine's circuitry is shown in Fig. 4.

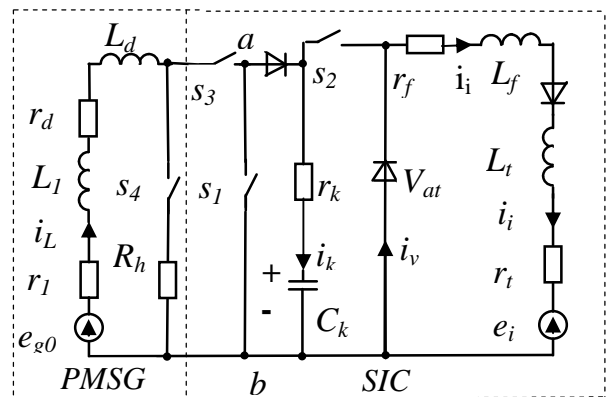

Fig. 4. Equivalent scheme of the system

Mathematical description of the system's power storage and inverting circuits (SIC) is developed well

enough in the previous papers published by authors [7, 10], therefore it will be skipped in this paper. Synchronous generator with permanent magnets (PMSG) can be loaded in two ways depending on state of the switches s_3 and s_4 :

- to supply the generated electric power into the heating element (HE, R_h) when s_3 is switched off and s_4 is switched on,
- to supply the power into the electric grid over the inverter, when s_3 is switched on and s_4 is switched off.

Therefore mathematical description of the wind-based water heating system must evaluate both ways of PMSG loading.

Permanent magnet synchronous generator (PMSG) can be described by means of the system of differential and algebraic equations as follows:

$$(6) \quad \left\{ \begin{array}{l} \frac{di_L}{dt} = \frac{1}{L_d} \cdot (u_d - r_d \cdot i_L - u_{ab}); \\ \frac{d\omega_g}{dt} = \frac{1}{J} \cdot (M_t - M_g - M_f); \\ u_d = e_{g0} - u_r - u_K - R_h \cdot i_L; \\ e_{g0} = \frac{2\sqrt{2} \cdot m}{\pi} \cdot U_{f0} \cdot \sin \frac{2\pi}{m} \cdot \sin \frac{\pi}{m}; \\ u_r = 2 \cdot r_1 \cdot i_L + 2 \cdot L_1 \cdot \frac{di_L}{dt}; \\ u_K = \frac{m \cdot x_K}{2 \cdot \pi} \cdot i_L; \\ M_t = \frac{P_t}{\omega_g \cdot i}; \\ M_f = k_f \cdot \omega_g; \\ M_g = k_m \cdot I_f; \\ I_f = i_L \cdot \sqrt{\frac{2}{3} - \frac{\gamma}{3 \cdot \pi}}; \\ \gamma = \arccos \left(1 - \frac{\sqrt{2} \cdot x_K \cdot i_L}{U_l} \right); \\ U_f = U_{f0} \cdot \sqrt{1 - \frac{\gamma}{\pi} + \frac{\sin 2\gamma}{2\pi}}; \end{array} \right.$$

where M_g – the torque of generator; M_t – the torque of wind rotor; M_f – the combined torque of viscous friction of rotor and load; J – the combined inertia of rotor and load; i – reduction (multiplication) factor of the gear; ω_g – the angular velocity of the generator’s rotor; k_m – torque factor; k_f – friction factor; P_t – the power produced by wind turbine; L_1 – the inductance of the generator’s winding.

System of equations (6) is valid for both modes of WT’s operation. When the generator is loaded by the heating element, the voltage $u_{ab} = 0$ and when the power from generator is supplied into the electric grid, the drop of voltage $R_h \cdot i_L = 0$.

Generator is rotated by the rotor of vertical wind turbine. Mathematical description of this WT is based on its power curve, which is given in wind turbine’s technical documentation. Polynomial of the sixthly order is used for the approximation of the power curve on purpose to have a sufficient adequacy the mathematical description. So, the

power curve of vertical wind turbine mathematically can be described by this equation

$$P_t = -0.0461 \cdot v_w^6 + 2.1317 \cdot v_w^5 - 36.5307 \cdot v_w^4 + 271.5777 \cdot v_w^3 - 731.0533 \cdot v_w^2 + 531.6232 \cdot v_w + 8.5174. \quad (7)$$

Mathematical model (Fig. 5) for the PMSG can be making up using the systems of equations (6) as well as equations (1÷5) and (7). Mathematical model (Fig. 5) of the storage and inverting circuits (SIC) is created by applied the previously works of an authors [7, 10].

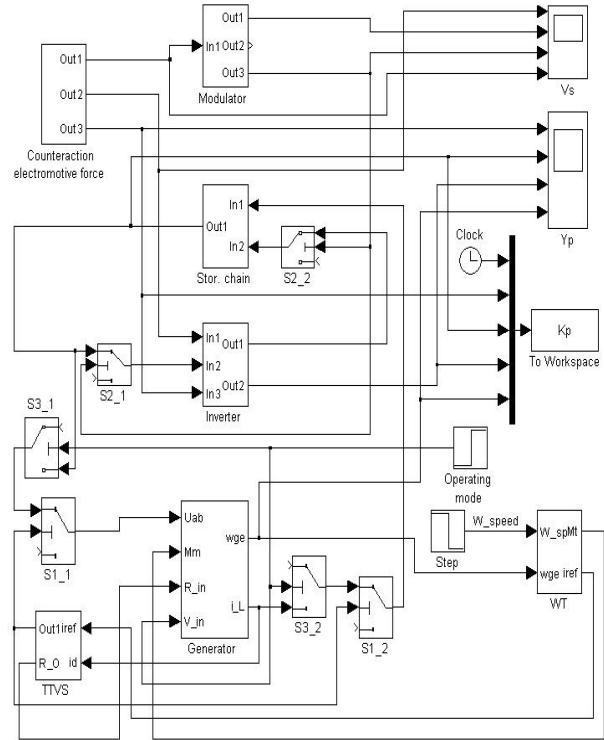

Fig. 5. Mathematical model for the WT’s power system

Mathematical model for the WT’s power system consist of three functional parts: the converter, which includes inverter, power storage circuit and control pulse former, witch includes counteraction electromotive force and modulator blocks, the generator and the wind turbine. Operating mode block is used to switch the system into the water heating mode or into the power inverting mode. TTVS block performs the control of generator’s load. The load of generator is controlled by means of varying the value of stator’s rectified current. The reference rectified current is calculated in the model’s block WT according to the following formula:

$$i_{LR} = \frac{P_t}{k_{is} \cdot k_m \cdot \omega_g}, \quad (8)$$

where k_{is} – coefficient of rectifier’s scheme (for three-phase six-pulse rectifier $k_{is}=0.78$).

The given current i_{LR} reaches the TTVS block through the inlet “iref” and the measured rectified current – through

the inlet “id”. The signal formed by the controller TTVS on its output “R_O” is sent to the generator of model.

Results of the WT’s load control system research

As it was mentioned above, WT can supply the converted wind energy to the water heating system or into the electric grid when the heat storage tank is fully charged. The load of WT must be properly (effectively) controlled in both cases. Quality of the load control in the proposed wind-based water heating system was researched by means of mathematical simulation. Results of simulation are presented below in form of experimental curves.

Results of research for the case when WT charges the heat storage tank are presented in Fig. 6. There is shown the process of control when the wind velocity suddenly drops from 9 m/s down to 5 m/s.

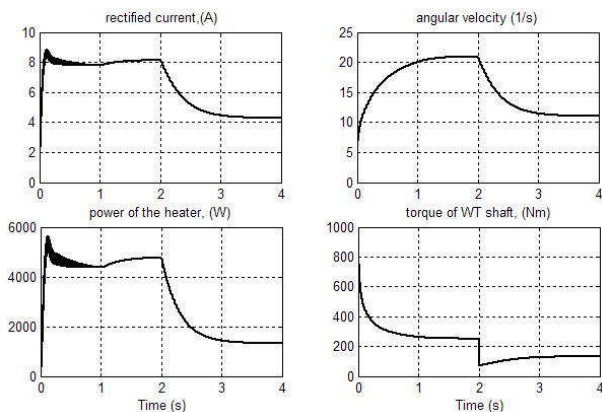

Fig. 6. Curves of the WT’s power system parameters at the jump of wind velocity v_w when system is working in heating mode (v_w jump from 9 to 5 m/s, at $t=2$ s)

As it can be seen from the curves, the WT’s load control process is sufficiently qualitative.

Similar curves were received at the same conditions for the case when the power from WT is supplied into the electric grid (Fig. 7).

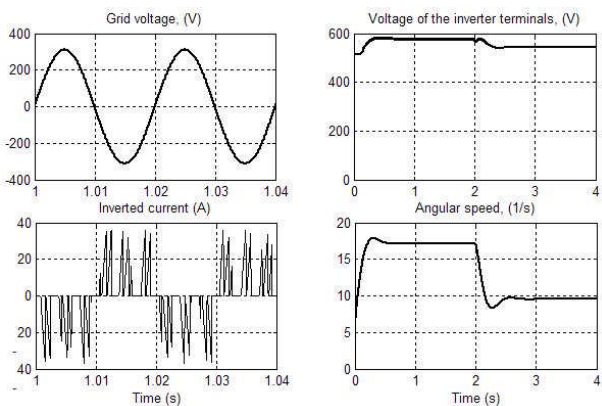

Fig. 7. Curves of the WT’s power system parameters at the jump of wind velocity v_w when system is working in energy conversion mode (v_w jump from 9 to 5 m/s, at $t=2$ s)

Analysis of the presented curves shows that process of the load control is fairly qualitative as well. The overregulation of the angular speed is not considerable. However the form of the inverted current is not sinusoidal. Therefore the filters for the inverted current must be installed on output of the inverter.

As we can see from Fig. 6 and Fig. 7, WT after the jump moves to another point of operation. After this the angular speed and torque of the WT, the rectified current and power of the generator’s stator decreases. Consequently, the power supplied as into heating unit, so into electric grid decreases as well.

Conclusions

1. Wind-based water heating systems already are becoming competitive in windy regions due to the skyrocketing prices of oil and natural gas.
2. Load of the wind turbine’s generator must be controlled dependently on the wind velocity in order to maximize the energy output.
3. The scheme of wind-based water heating system with WT’s load control and temperature of heated water control is suggested in this paper.
4. Temperature of water in the heat storage tank is controlled by means of the two-step controller.
5. The suggested scheme allows supplying the surplus of electric power from WT into electric grid when the heat storage tank is fully charged.
6. Control of the water heating process and the power supplying into electric grid process in the suggested scheme is realised by using the pulse-width modulator.
7. Mathematic model for the presented water heating system was worked out and researched.
8. Research of the mathematical model disclosed that using of the pulse-width modulator allows controlling the water heating process (Fig. 6) and the power supplying into electric grid process (Fig. 7) rather efficiently.

References

1. Danish Wind Power Association. Accessed at: <http://www.windpower.org/en/tour/htm>. – Accessed on December 28, 2007.
2. **Adomavičius V.** Sizing of wind-based energy system for homestead’s power and heat // Proceedings of International Conference “Electrical and Control Technologies – 2007”. – Kaunas University of Technology, Kaunas. – 2007. – P. 157–162.
3. **Adomavičius V.** Domestic heat and power from one renewable energy source // Lietuvos taikomųjų mokslų akademijos mokslo darbai. Tarptautinis inovacinis taikomųjų mokslų darbų žurnalas. – Klaipėda: KU leidykla, ISSN 1822-0754, 2007. – Nr. 5. – P. 15.
4. **Rolf Grünbaum.** Voltage and power quality control in Wind Power applications by means of dynamic compensation. – ABB Power systems AB, AC Power Division Vasteras. Sweden. Accessed at: [http://library.abb.com/GLOBAL/SCOT//scot221.nsf/VerityDisplay/B7EE91B76F899B80C1256FDA003B4D20/\\$File/PQ2000_Boston.pdf](http://library.abb.com/GLOBAL/SCOT//scot221.nsf/VerityDisplay/B7EE91B76F899B80C1256FDA003B4D20/$File/PQ2000_Boston.pdf). – Accessed on 10 02 2007.

5. **Erlich I., Winter W., Dietrich A.** Advanced Grid Requirements for the Integration of Wind Turbines into the German Transmission System // Power Engineering Society General Meeting, IEEE. – June 18–22, 2006. – 7 p.
6. **Ramonas Č., Kepalas V., Adomavičius V.** Iš atsinaujinančių šaltinių gautos energijos konversijos procesų tyrimas // Elektronika ir elektrotechnika. – Kaunas: Technologija, 2006. – Nr. 2(66). – P. 78–83.
7. **Paulauskas M., Kepalas V., Ramonas Č.** Platuminio asinchroninio ventulinio kaskado dinamika // ISSN 1392 – 1215. – Elektronika ir elektrotechnika, 1996. – Nr. 4(8). – P. 56–58.
8. **Ion Boldea.** Variable speed generators. – London, New York: CRC Taylor & Francis, 2006. – 546 p.
9. **Осин И. Л., Шакарян Ю. Г.** Электрические машины. Синхронные машины. – Москва: «Высшая школа». – 1990. – 304 с.
10. **Ramonas Č., Kepalas V., Adomavičius V.** Connection of the RES-based Power Plants into the Electric Grid // Electronics and Electrical Engineering. – Kaunas: Technologija, 2007. – No. 8(80). – P. 67–72.

Received 2008 03 12

V. Adomavičius, Č. Ramonas, V. Kepalas. Control of Wind Turbine's Load in order to maximize the Energy Output // Electronics and Electrical Engineering. – Kaunas: Technologija, 2008. – No. 8(88). – P. 71–76.

Small-scale wind-based water heating system is proposed and researched. System has a small wind turbine with permanent magnet synchronous generator loaded by the heating element, which is placed in the heat storage tank. The pulse-width modulator is used for the load control. The suggested scheme allows supplying the surplus of electric power from the WT into electric grid in cases when the heat storage tank is fully charged. Control of the water heating process and the power supplying into electric grid process in the researched scheme is realised by using the load control unit, two-step controller and the pulse-width modulator. Mathematic model for the presented water heating system was worked out and researched. Research of the mathematical model disclosed that using of the pulse-width modulator allows controlling the water heating process and the power supplying into electric grid rather efficiently. The possibility to maximize the wind turbines power by adjusting the load to every value of the wind velocity was checked. Results of the simulation also allowed estimating that the form of the inverted current is not sinusoidal. Therefore the filters for the inverted current must be installed on output of the inverter. Ill. 7, bibl. 10 (in English, summaries in English, Russian and Lithuanian).

В. Б. Адомавичюс, Ч. С. Рамонас, В. П. Кепалас. Регулирование нагрузки ветроэлектростанции с целью получения максимальной отдачи // Электроника и электротехника. – Каunas: Технология, 2008. – No. 8(88). – P. 71–76.

Рассматриваются вопросы использования ветроэлектростанций малой мощности для производства тепловой энергии и передачи неиспользуемой энергии в электросеть. Рассматривается ветроэлектростанция с синхронным генератором с постоянными магнитами. Чтобы получить максимальное использование энергии ветра и электростанции, при изменении скорости ветра приходится регулировать величину нагрузки. В статье рассматривается широтно-импульсное регулирование нагрузки для случаев, когда ветроэлектростанция соединена с электрической сетью и когда к ней присоединен тепловой элемент нагрева. Создана математическая модель ветроэлектростанции с широтно-импульсным регулированием нагрузки для обоих случаев. Результаты моделирования показывают, что при использовании широтно-импульсного регулирования нагрузки генератора для обоих случаев, т.е. когда вся энергия передаётся в теплонакопитель или в электросеть, возможно максимально достигаемое использование мощности ветра для данной ветроэлектростанции. Исследования показали, что в случае работы ветроэлектростанции в режиме инвертирования энергии, передаваемая в сеть энергия несинусоидальна. По этому при соединении ветроэлектростанции с электросетью нужно использовать электрические фильтры. Ил. 7, библи. 10 (на английском языке; рефераты на английском, русском и литовском яз.).

V. Adomavičius, Č. Ramonas, V. Kepalas. Vėjo elektrinės apkrovos valdymas siekiant maksimizuoti jos energijos gamybą // Elektronika ir elektrotechnika. – Kaunas: Technologija, 2008. – Nr. 8(88). – P. 71–76.

Nagrinėjamos nedidelės galios vėjo elektrinių generuojamos elektros energijos naudojimo galimybės vandeniui šildyti bei atliekamos elektros energijos tiekimo į elektros tinklą klausimai. Nagrinėjamoje schemoje naudojamas sinchroninis generatorius su nuolatinais žadinimo magnetais. Nurodyta, kad, norint maksimaliai panaudoti vėjo turbino kuriamą galią, būtina reguliuoti generatoriaus apkrovos dydį. Darbe siūlomas platuminis-impulsinis apkrovos reguliavimo būdas tiek vėjo elektrinei tiekiant energiją vandens šildymo elementui, tiek invertuojant jos pagamintą energiją į tinklą. Sudarytas tokios vėjo elektrinės matematinis aprašymas. Sistemos kaupimo invertavimo dalies matematiniam aprašymui sudaryti panaudoti ankstesni autorių darbai. Sudarytas tokios vėjo elektrinės, dirbančios su kaitinimo elementu, arba invertuojančios energiją į tinklą, apkrovos valdymo matematinis modelis. Modeliavimo rezultatai rodo, kad naudojant platuminį šių dviejų VE darbo režimų valdymą – kai visa energija atiduodama šilumos kaupikliui arba perduodama į elektros tinklą, galima maksimaliai išnaudoti vėjo turbino galią. Tyrimai parodė, kad vėjo elektrinei dirbant energijos invertavimo į tinklą režimu, invertuojama srovė yra nesinusinė. Todėl inverteriui sujungti su tinklu būtina naudoti filtrus. Il.7, bibl. 10 (anglų kalba, santraukos anglų, rusų ir lietuvių k.).

DOI: 10.5755/j02.eie.11347