

Two-step Pulse Mode Control of the Discrete Material Dosing

Č. Ramonas

Department of Control Technology, Kaunas University of Technology,
Studentų str. 48, LT-51367 Kaunas, Lithuania, phone: +370 37 300274, e-mail: ceslovas.ramonas@ktu.lt

Introduction

Dosage of the discrete material is used in various branches of industry – chemical, food, building and other on purpose to manufacture products with various characteristics. Efficiency of the technological line and quality of production substantially depends on rapidness of operation of discrete material dosage mechanisms and on dosage precision.

The research is devoted to the elaboration of more efficient discrete materials dosage control system used in concrete production. Research of the proposed system's accuracy depending on some system parameters is made.

Functional diagram of discrete materials dosage automation

Weighing is mostly used dosage method [2] because it is more precise in comparison with flow rate measuring method [3]. The discrete material from feed-tank flows out to weighing tank through valve V as functional diagram in Fig. 1 shows. Discrete material (DM) weight is measured up by transducer WT . Weight signal from WT is sent to the weight controller WC . The controller compares this signal with the reference signal received from the reference unit HW and generates the control signal to the actuator (A), which uncloses or closes the valve V . Simple two-step mode electro-pneumatic actuators are usually used in such systems. Valves with such actuators have two positions: unclosed or closed. The two-step controllers are used to control them. The electro-pneumatic actuators are quick-acting devices.

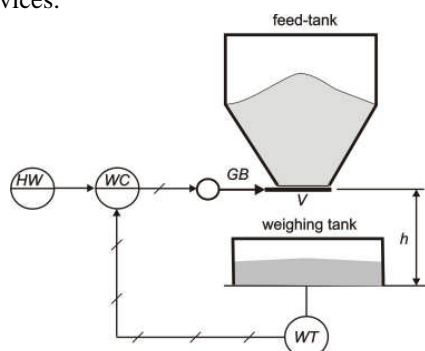

Fig. 1. Function diagram of dosage automation

Some amount of discrete material flows into weighing tank during the time that is needed to close the valve. So, the close valve switching advance is used to get the desirable accuracy of dosing. It is very hard to determine precise of the switching advance due to the physical and chemical properties of the discrete material (material dampness, stratification, granulanness, etc.) and construction peculiarities of the tanks. The switching advance is mostly determined by set of experiments. Its approximate (average) value must be adjusted to the changing physical and chemical properties of the discrete material technological process. It increases complexity and cost of the dosage control system.

Algorithm for controller operation of the two-step pulse mode control system

The two-step pulse mode automatic dosage system is researched in this work. The system operates as follows. The valve V is unclosed at the start of dosage (Fig. 1) and material flows into weighing tank with rated stream speed. When the weight of material achieves a value close to the rated one, the controller is switched to periodical pulse mode operation. So, the discrete material starts to flow into the weighing tank periodically in small portions. This process will continue as long as it will be necessary to achieve the rated value of weight of the discrete material. Algorithm presented in Fig. 2 shows the operation of the controller of the DM automatic dosage system. Primary data such as DM weight reference value, controller switching to pulse mode value, dosage accuracy value, pulse width and period of dosage are set to controller at the initialization (2). Signal at the controller output depends on condition presented in block (3). If true is "NOT", then controller will form the signal for actuator switching (block 4) to unclosed the valve. This will result into the discrete material flows to weighing tank with rated speed. If true is "YES", then controller forms pulse signal at the output that will switch the actuator to pulse mode (block 5). The discrete material will flow into the weighing tank periodically in small portions as long as error decreases to the value that will satisfy an accuracy condition (block 8).

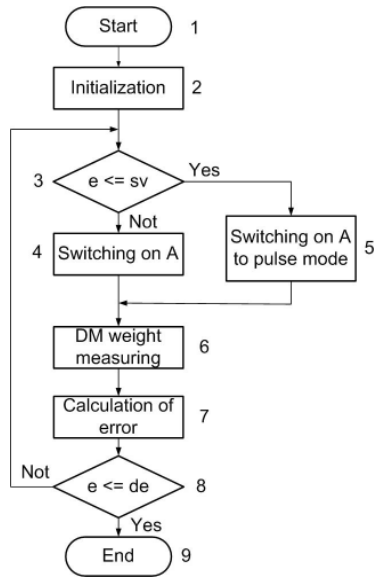

Fig. 2. Algorithm of the controller of DM automatic dosage system

Weight of the weighing tank is measured and weighing error is calculated constantly (block 7). The weighing is stopped when condition $e \leq de$ is satisfied.

Block diagram of automatic dosage of the discrete materials

The block diagram of the two-step pulse mode dosage control system (Fig. 3) consist of the controller W_c , the actuator W_a , the plant W_p and the transducer of feedback W_f .

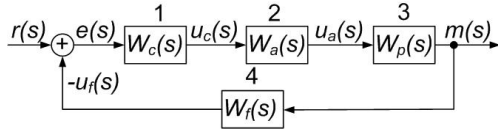

Fig. 3. Block diagram of DM automatic dosage control system

The steady-state characteristic of two-step pulse mode controller can be described as follows:

$$u_c(t) = \begin{cases} U_{cm}, & kai \quad e \geq sv, \\ U_p(t), & kai \quad de \leq e \leq sv, \\ 0, & kai \quad e \leq de. \end{cases} \quad (1)$$

$$U_p(t) = U_{cm} \sum_{k=0}^{\infty} (1(t - kT_c) - 1(t - (kT_c + \tau))), \quad (2)$$

where $U_p(t)$ – the pulse function; e – the error; sv – the value of controller switching to pulse mode; de – the permissible error value; U_{cm} – the value of controller output signal; τ – the pulse width; T_c – the pulse repetition period.

The variables named above are the controller tuning parameters. The controller is nonlinear and has changeable structure.

Actuators (A) in general have some inertia, so they can be described by transfer function as follows:

$$W_a(s) = \frac{u_a(s)}{u_c(s)} = \frac{k_a}{T_a \cdot s + 1}, \quad (3)$$

where u_a – the output of actuator, [%]; u_c – the output of controller, [V]; k_a – the constant of actuator; T_a – the time constant of actuator.

The weighing tank (WT) is filled up with discrete material by only gravitational force. The method of such WT filling is low-priced. Some factors named above have big influence on the speed of DM flows to the WT. So, it is very hard to get fairly correct expressions for the calculation of the flow speed of DM [3, 4]. Maximal speed of flow of DM depends on throughput of tank. So, with accuracy sufficient for practical purposes it can be calculated as follows [4]:

$$Q = 3600 \cdot A \cdot \gamma \cdot F \cdot \sqrt{R_h}, \quad (4)$$

where A – the coefficient depending from material characteristics; γ – the density of filling of the weighing tank, [kg/m³]; F – the cross-section of the tank outlet, [m²]; R_h – the hydraulic radius of the outlet, [m].

The hydraulic radius of the outlet depending on form of vent can be calculated as follows:

a) for rectangular with sides a and b

$$R_{hr} = \frac{a \cdot b}{2 \cdot (a + b)}; \quad (5)$$

b) for circle with diameter a

$$R_{hc} = \frac{a}{4}; \quad (6)$$

c) for square with side a

$$R_{hs} = \frac{a}{4}. \quad (7)$$

Weight of mass of the DM in the weighing tank can be calculated as follows:

$$m = \int_0^{t_w} Q(t) dt, \quad (8)$$

Transfer function of the plant then will be as this:

$$W_p(s) = \frac{m(s)}{u_a(s)} = \frac{10 \cdot A \cdot \gamma \cdot F \cdot \sqrt{R_h}}{s}, \quad (9)$$

where $m(s)$ – mass of the DM in weighing tank, [kg].

Transducers in common case also have some inertia so they can be described by transfer function as follows:

$$W_f(s) = \frac{u_f(s)}{m(s)} = \frac{k_f}{T_f \cdot s + 1}, \quad (10)$$

where u_f – feedback signal of weight, [V]; k_f – feedback coefficient of weight, [V/kg]; T_f – time constant of weight transducer, [s].

The system of dosage is nonlinear because of nonlinear blocks (controller, actuator). Methods of mathematical modeling are most common for research of this kind of system.

Mathematical model of automatic dosage of the discrete materials

Mathematical model of two-step pulse mode control of dosage of the discrete material (Fig. 4) is designed in accordance with block diagram of control system (Fig. 3) and control algorithm (Fig. 2).

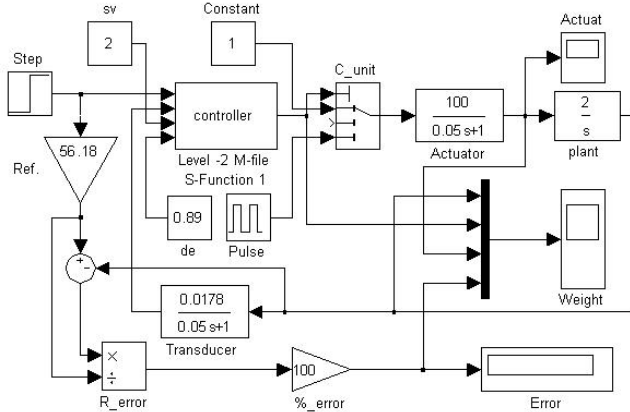

Fig. 4. Mathematical model of two-step pulse mode control of dosage of the discrete material's

Package of program MATLAB/SIMULINK is used for mathematical modeling. Mathematical model (Fig. 4) consist of four functional part's: tuning, performance, plant and feedback. Tuning part consist from controller, commutation unit "C_unit", generator "Pulse" and block's which are set control mode for controller (Constant, sv and de).

The program of controller operation is designed according to the algorithm (Fig. 2). The parameters of its switching condition are calculated as follows:

$$de = 0.01 \cdot \Delta \cdot k_f \cdot m, \quad (11)$$

$$sv \cong (0.2 \div 0.25) \cdot k_f \cdot m, \quad (12)$$

where Δ – dosing accuracy of the discrete material, [%].

Pulse width τ and repetition period T_c are defined after mathematical modeling.

The mathematical models of the actuator, plant and transducer are used to define the equivalent parts of dosage automation system (Fig. 4).

The block "Step" refers to the requested weight of the dosed material. The other blocks are used for dosage accuracy calculating and for some signal's indicating.

Research of the discrete material's dosage system

Researches of dosage system of the discrete materials have been performed by using derived mathematical model. The model with applying experimental data is adopted for discrete materials used for producing concrete compounds. So for the model of plant block is used with discrete material where the flow speed from the feed-tank is obtained experimentally and equals to 200 kg/s. The rated amount of dosing material is 500 kg. High requirements for dosage by weighing are raised. The process of dosage must be monotonous, can't be any

overshoots because eliminating of material excess from weighing tank is not projected.

The results of the system dynamics are presented in Fig. 5 and Fig. 6. Four time dependencies such as mass of dosage material, controller output signal, actuator output signal and error is presented in Fig. 5. The controller forms at output conditional signals with values 1, 2 and 3. If at controller output is 1 then the actuator is switched to operating in permanent mode (valve unclosed). When at controller output is 3 the actuator is switched on to pulse mode (the valve periodically unclosed for short time). So material to weighing tank is feeding in small portions. Such process is run until the mass of material achieves the desirable value with permissible accuracy. The quantity Δ is permissible accuracy while quantity Δ_c is current accuracy calculated by mathematical model.

When material mass achieves desirable value the controller forms signal 2 at the output and the commutation unit switches off the actuator (valve is closed).

The dosage dynamics results are presented at Fig. 5. It shows that dosage quality is good enough. At the same time current dosage accuracy is higher than permissible accuracy (Δ).

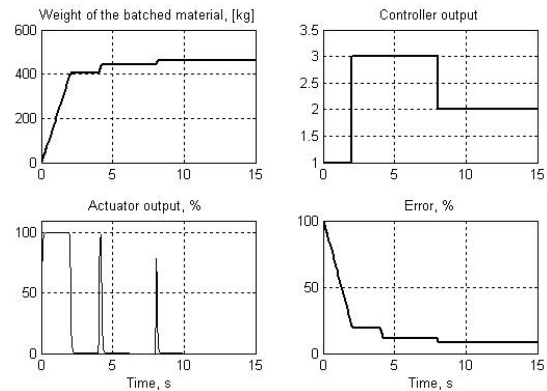

Fig. 5. Dosage curves, when $T_p=0.5$ s; $k_a=100$; $T_a=0.05$ s; $k_f=0.0178$ V/kg; $T_f=0.02$ s; $de=0.89$ V; $sv=2$ V ($\Delta=10$ % $\Delta_c=7.9$ %); (the parameters of generator: $A=1$ V; $T_c=4$ s; $\tau_p=0.2$)

The influence of actuator inertness for dosage accuracy research is presented in Fig. 6.

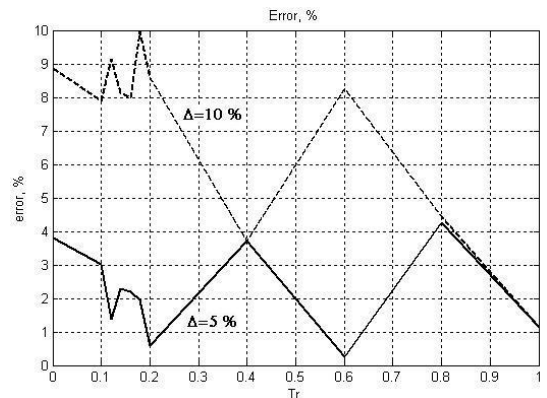

Fig. 6. Dosage accuracy dependency on relational time constant of actuator, when $T_p=0.5$ s; $k_a=100$; $k_f=0.0178$ V/kg; $T_f=0.02$ s; (the parameters of generator: $A=1$ V; $T_c=4$ s; $\tau_p=0.2$ s)

Here presented accuracy dependencies from relational time constant of actuator for two cases: with the permissible accuracy error equal to 5 and to 10 percent's. The relational time constant of actuator is calculated as follows:

$$T_r = \frac{T_a}{T_p}, \quad (13)$$

where T_p – plant time constant.

From the Fig. 6 it is seen that there is no functional relation between dosage accuracy and actuator inertness. The dosage error value is distributed randomly within limits of permissible accuracy.

Conclusions

1. The dynamics of the discrete material dosage with two-step pulse mode controller meets the monotony requirement. The required dosage accuracy has been received.
2. The mathematical dependencies established here let to calculate the tuning parameters of two-step pulse

mode controller with accuracy sufficient for practical purposes.

3. The dosage error depends from the time constant of actuator and its value is random quantity, which stays within the limits of permissible accuracy.

References

1. **Yanlin Li and E. B. Lee.** Two-step High Performance Nonlinear Control System Design // Proceedings of the 31st Conference on Decision and Control. – Tucson, Arizona, December 1992. – P. 3013–3018.
2. **Gasiūnas T., Daunoras J.** Betono mišinio gamybos valdymo analizė // Automatika ir valdymo technologijos – 2002, konferencijos pranešimų medžiaga. – Kaunas: Technologija, 2002. – P. 165–167.
3. **Катальмов А. В., Любартович В. А.** Дозирование сыпучих и вязких материалов. – Ленинград: Химия, Ленинградское отделение, 1990. – 240 с.
4. **Рогинский Г. А.** Дозирование сыпучих материалов. – Москва: Химия, 1978. – 174 с.

Received 2008 04 28

Č. Ramonas. Two-step Pulse Mode Control of the Discrete Material Dosing // Electronics and Electrical Engineering. – Kaunas: Technologija, 2008. – No. 7(87). – P. 73–76.

The two-step pulse mode control of dosing of the discrete material is analyzed in this article. The controller at first of dosage operates in two-step mode. When dosage is coming to an end the controller is commutated to operate in pulse mode with constant pulse width and period. Such method of control lets get more precise dosing of the discrete material. The functional diagram, operating algorithm of two-step pulse mode controller, structural diagram and mathematical description of dosage system of the discrete material are developed in this article. The dosage control system essentially is non-linear. That is because the method of mathematical modelling is used for research of dosage. Mathematical model is created by using MATLAB/SIMULINK program package. Researches show that quality of control system mainly depends from the parameters of controller: from controller commutation to the pulse mode point, pulse width and period of cycle. It is determined the time constant of actuator has main influence to commutation point of controller. Recommendations to determine of tuning parameters of the controller are presented in this work. Ill. 6, bibl. 4 (in English, summaries in English, Russian and Lithuanian).

Ч. С. Рамонас. Позиционно-импульсное управление дозирования сыпучих материалов // Электроника и электротехника. – Каунас: Технология, 2008. – № 7(87). – С. 73–76.

Рассматривается позиционно-импульсная система управления дозирования сыпучих материалов (СМ). В начале дозировки регулятор работает в двухпозиционном режиме, а в конце он переключается в режим импульсного управления с импульсами управления, обладающими постоянной шириной и периодом. В работе представлены функциональная схема автоматизации системы дозирования СМ, алгоритм функционирования позиционно-импульсного регулятора, структурная схема системы управления и математическое описание звеньев структурной схемы. Система управления дозирования СМ является по существу нелинейной, поэтому для исследования системы был применен метод математического моделирования. Разработана математическая модель системы управления с применением программного пакета „MATLAB/SIMULINK“. Исследования показали, что в основном качество системы управления дозирования СМ зависит от параметров регулятора: от момента переключения регулятора в импульсный режим работы, а также от ширины и периода повторения импульсов управления. Установлено, что в основном на момент переключения регулятора влияет инерционность управляющего механизма. В работе даны рекомендации для определения параметров настройки регулятора. Ил. 6, библи. 4 (на английском языке; рефераты на английском, русском и литовском яз.).

Č. Ramonas. Pozicinis-impulsinis birių medžiagų dozavimo valdymas // Elektronika ir elektrotechnika. – Kaunas: Technologija, 2008. – Nr. 7(87). – P. 73–76.

Straipsnyje nagrinėjama birių medžiagų dozavimo pozicinė-impulsinė valdymo sistema. Dozavimo pradžioje regulatorius veikia dviejų pozicijų režimu, o pabaigoje jis perjungiamas į impulsinį režimą su vienodo pločio impulsais ir pastoviu impulsų pasikartojimo periodu. Darbe pateikiama dozavimo sistemos funkcinė automatizavimo schema, pozicinio-impulsinio regulatoriaus funkcionavimo algoritmas, dozavimo sistemos struktūrinė schema ir struktūrinės schemos grandžių matematinis aprašymas. Birių medžiagų dozavimo valdymo sistema yra iš esmės netiesinė, todėl jai tirti buvo taikomas matematinio modeliavimo metodas. Naudojant „MATLAB/SIMULINK“ programavimo paketą sudarytas valdymo sistemos matematinis modelis. Atlikti tyrimai parodė, kad dozavimo valdymo sistemos kokybė priklauso nuo sistemos grandžių parametrų ir ypač nuo regulatoriaus parametrų: nuo regulatoriaus perjungimo į impulsinį darbo režimą momento, nuo valdymo impulso pločio bei impulsų pasikartojimo periodo. Nustatyta, kad didžiausią įtaką regulatoriaus perjungimo momentui turi vykdomo mechanizmo laiko pastovioji. Darbe pateiktos rekomendacijos, kaip nustatyti regulatoriaus suderinimo parametrus. Il.6, bibl. 4 (anglų kalba, santraukos anglų, rusų ir lietuvių k.).

DOI: 10.5755/j02.eie.11218