

Variable Speed Drive Supplied by the Voltage Formed using Special-purpose Algorithm

A. Petrovas, S. Lisauskas, V. Batkauskas

*Automation Department, Vilnius Gediminas Technical University,
Naugarduko str. 41, LT-03227, Vilnius, Lithuania; e-mail: vygintas.batkauskas@el.vtu.lt*

A. Baškys

Semiconductor Physics Institute A. Gostauto str. 11, LT-01108, Vilnius, Lithuania, e-mail: mel@pfi.lt

Introduction

The paper discusses modeling and simulation of the AC induction motor drive supplied by the frequency converter with output voltage formed using special-purpose algorithm called SVPFM (Space Vector Pulse Frequency Modulation) [1]. Using this algorithm motor rotation speed is controlled by a scalar control method where ratio U/f_p (output voltage/phase frequency) is kept constant. Set of differential equations of the AC induction motor for development of the model is derived. The motor model is developed in a stationary reference frame. The obtained simulation results of motor speed and currents are presented and analyzed. The experimental investigation results of current spectrum of AC induction motor supplied by the frequency converter, which generates output voltage using the SVPFM method, are presented as well.

Space vector pulse frequency modulation

The output voltage of frequency converter, which supplies AC induction motor, must be changed within wide ranges. The best form of output voltage would be sinus but output switches of converter are able to provide the series of pulses with constant amplitude U_{DC} only. The proper choice of pulse parameters eliminates or minimizes amplitudes of harmonics in initial part of the spectrum. The frequency of fundamental harmonic is named as phase frequency f_p and frequency of pulses - as carrier frequency f_c .

The usage of different zero vectors in space vector modulation methods gives different algorithms of inverter switches commutation [1]. In those definitions modulation index m may changes from 0 up to $2/\sqrt{3}$. Interval $1 < m < 2/\sqrt{3}$ means the over modulation mode. In interval $0 \leq m \leq 1$ the modulation index provides the variation of length of frequency converter output voltage vector V_{ref} in regions from zero ($m=0$) to nominal value ($m=1$).

$$m = f_p / f_{nom}, \quad (1)$$

where f_{nom} – nominal phase frequency (usually $f_{nom} = 50\text{Hz}$).

The carrier frequency in the SVPFM method is proportional with phase frequency $f_c / f_p = M$. The algorithms of switches commutation and maximum value of first harmonic amplitude using SVPFM method are the same as in case of widely used Space Vector Pulse Width Modulation (SVPWM) method. The voltage of SVPFM method with ratio M and voltage of SVPWM method with $f_c = M f_{nom}$ coincide at the point $f_p = f_{nom}$. Voltage generated by SVPFM method has discrete spectrum and enough stable level of high harmonics in wide range of frequency f_p , but spectrum characteristics are worse than ones of SVPWM for $f_p < f_{nom}$ [1].

Simple and easy generation of signals and consequently, low requirements for units of converter is the main advantage of SVPFM method over the SVPWM method. The pulses are generated for V_{ref} at fixed values of angle φ : $\varphi_j = 2 \pi j / M$, $j = 1, 2, \dots, M$, therefore isn't necessary to calculate trigonometric functions using SVPFM method. In situation when M is divisible by 6 the angles φ are situated equally in all sectors, therefore only $M/6$ values of sinus must be stored in the data memory of microcontroller [1].

Model of the induction motor drive in stationary reference frame

Dynamic performance of an AC induction motor is complex problem taking into account three-phase rotor windings moving with respect to three-phase stator windings. The coupling coefficient changes continuously with the change of rotor position θ_r and motor model is described by differential equations with time varying mutual inductances. To simplify the problem solution, any three phase induction motor can be represented by an

equivalent two phase motor, where $d^s - q^s$ – stator direct and quadrature axes as well as $d^r - q^r$ – rotor direct and quadrature axes. The problem becomes simple, but problem of time varying parameters still remains. Park transformation refers the stator variables to a synchronous reference frame, fixed on the rotor. It results to all time varying inductances being eliminated. The other kind of transformation widely used is G. Kron transformation, relating both stator and rotor variables to a synchronously rotating reference frame that moves with the rotating magnetic field. Time-varying inductances in the voltage equations of an induction motor also can be eliminated by transforming rotor variables to variables associated with fictitious stationary windings. In this case, the rotor variables are transformed to a stationary reference frame fixed on the stator. This method was proposed by H. S. Stanley [2].

The paper presents a mathematical model of the induction motor in a stationary reference frame. A mathematical model of the linear induction motor in stationary reference frame α, β developed for the linear motor is presented in [3]. For revolving induction motor it can be written as [4]:

$$\begin{cases} u_{ds}^s = \left[\left(\frac{1}{L_s} + \frac{L_m k_1}{L_s L_r} \right) \cdot \psi_{ds}^s - \frac{L_m}{L_s L_r} \cdot \psi_{ds}^r \right] \cdot R_s + \frac{d\psi_{ds}^s}{dt}; \\ u_{qs}^s = \left[\left(\frac{1}{L_s} + \frac{L_m k_1}{L_s L_r} \right) \cdot \psi_{qs}^s - \frac{L_m}{L_s L_r} \cdot \psi_{qs}^r \right] \cdot R_s + \frac{d\psi_{qs}^s}{dt}; \\ u_{ds}^r = \left[\frac{1}{L_r} (\psi_{ds}^r - k_1 \cdot \psi_{ds}^s) \right] \cdot R_r + \frac{d\psi_{ds}^r}{dt} + \omega_r \cdot \psi_{qs}^r; \\ u_{qs}^r = \left[\frac{1}{L_r} (\psi_{qs}^r - k_1 \cdot \psi_{qs}^s) \right] \cdot R_r + \frac{d\psi_{qs}^r}{dt} + \omega_r \cdot \psi_{ds}^r, \end{cases} \quad (2)$$

where $\psi_{ds}^s, \psi_{qs}^s, i_{ds}^s$ and i_{qs}^s – stator flux linkages and currents aligned with the direct axis; $\psi_{ds}^r, \psi_{qs}^r, i_{ds}^r, i_{qs}^r$ – stator flux linkages and currents aligned with quadrature axis; R_s – stator phase resistance, R_r – rotor phase resistance, referred to stator; $u_{ds}^s, u_{qs}^s, u_{ds}^r, u_{qs}^r$ – stator and

rotor voltages. In the stationary reference frame $u_{ds}^s = U_{1\max} \cos \omega_0 t$, $u_{qs}^s = U_{1\max} \sin \omega_0 t$ where $U_{1\max}$ – amplitude of voltage and $\omega_0 = 2\pi f$ – angular frequency. L_m – magnetizing inductance, $L_s = L_{1s} + L_m$ – stator inductance, L_{1s} – stator leakage inductance; $L_r = L_{1r} + L_m$, L_{1r} – rotor leakage inductance referred to stator and $k_1 = L_m / L_s$.

Torque delivered by motor is calculated as:

$$T = \frac{3}{2} p \cdot (\psi_{ds}^s \cdot i_{qs}^s - \psi_{qs}^s \cdot i_{ds}^s), \quad (3)$$

where p – number of pole pairs.

The simulation model of the induction motor is presented in Fig. 1. The model consists of models for power supply, PWM inverter, induction motor drive in the stationary reference frame and space vector pulse frequency modulation block.

The motor model has been realized using the actual parameters of the induction motor presented in the Table 1.

Table 1. Parameters of the induction motor

Parameter	U	P	n	R_s	L_s	R_r	L_r
Units	[V]	[kW]	[rpm]	[Ω]	[mH]	[Ω]	[mH]
Value	380	4	2890	1,55	5,2	1,04	9,3

The developed model of the induction motor can be used with various motor parameters in order to analyze different transients in the motor with desired load on the shaft [4].

The simulation and experimental investigation were performed for the carrier and phase frequencies listed in the Table 2.

Table 2. Values of carrier frequency f_c and phase frequency f_p

f_c	960	960	960	1920	2880	3840
f_p	5	7	10	20	30	40

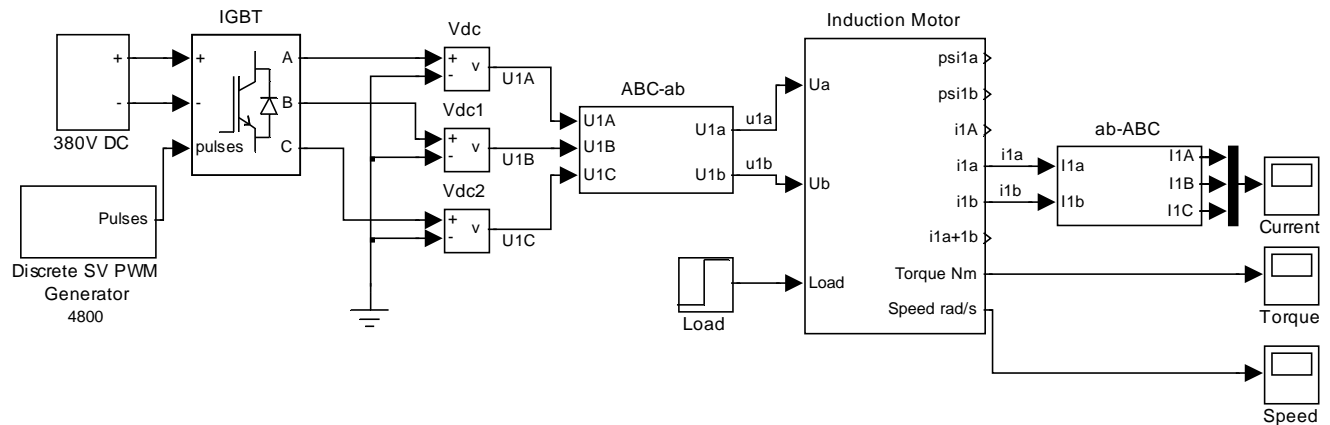

Fig. 1. The Simulink model of the induction motor supplied by the frequency converter

Experimental investigation results of motor steady-state speed at no-load at different f_p are presented in Fig. 2. Fig. 3 presents simulated currents of motor at starting.

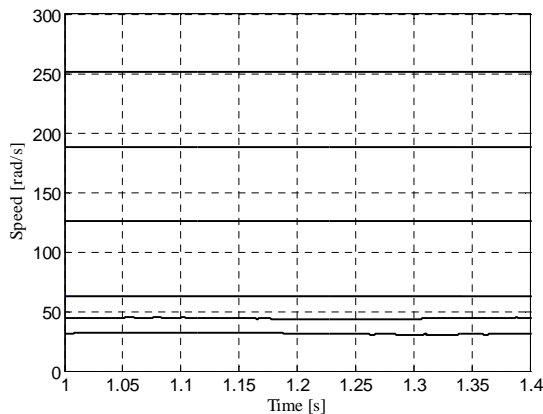

Fig. 2. Experimental results of motor steady-state speed at no-load at different f_p given in Table 2

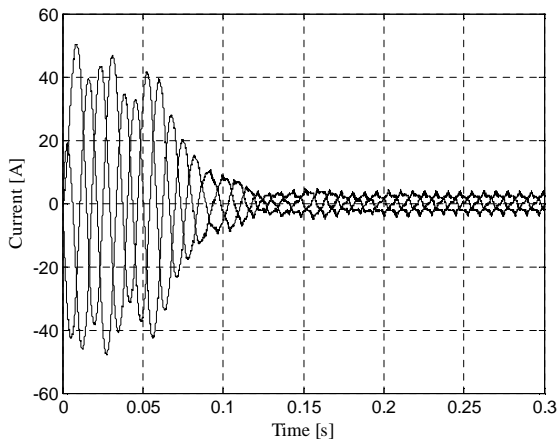

Fig. 3. Starting transients of motor current at no load at $f_c = 4320$ Hz, $f_p = 45$ Hz

The experimental investigation of the motor current spectrum

The experimental investigation was carried out in order to obtain the current spectrum of the motor supplied by the voltage formed using SVPFM method discussed in this paper.

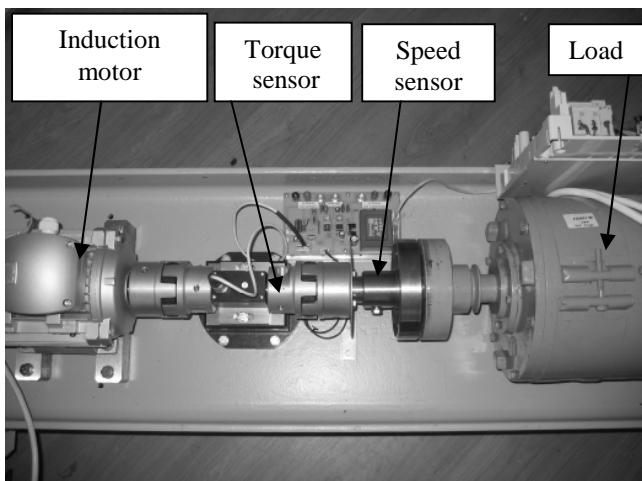

Fig. 4. The laboratory setup for experimental investigation

The following instruments were used for the experimental investigation: Tektronix TPS2024B oscilloscope; current clamps; torque sensor DR-2212-R produced by the Lorenz Messtechnik GMBH; optical sensor for motor rotation speed measurement; PC with Open Choice Desktop software installed. The picture of the laboratory setup for investigation is presented in Fig. 4.

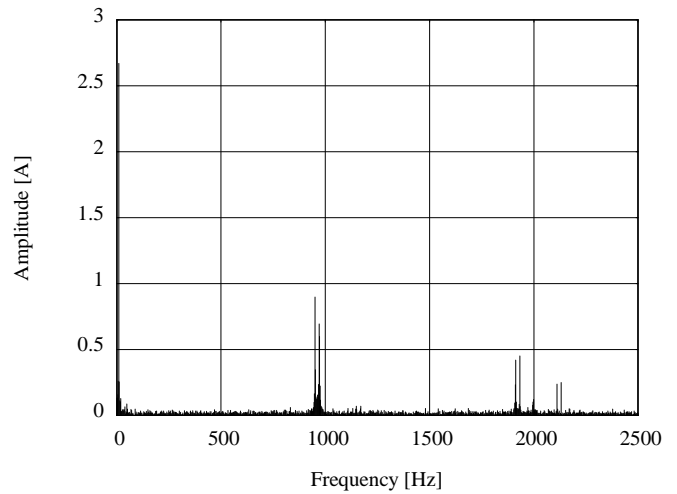

Fig. 5. Motor current spectrum at $f_p = 10$ Hz

The frequency converter developed in the Microelectronics Laboratory has been used for investigation. Main specifications of frequency converter listed below:

- Supply voltage: 3 phase 380 V, 50 Hz;
- Output voltage: 5 to 380 V;
- Phase frequency of output voltage 0 – 50 Hz;
- Output power: 4 kW.

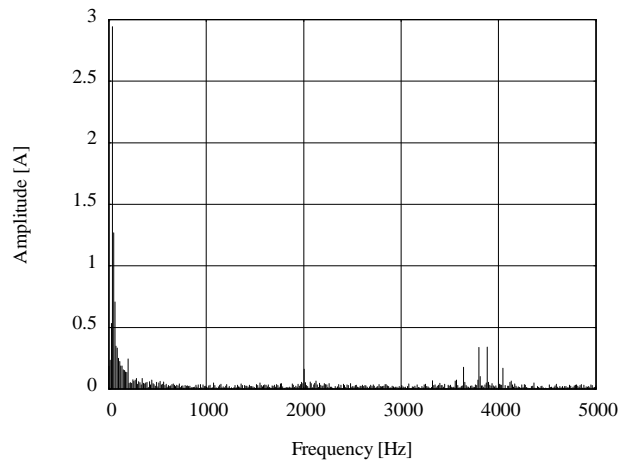

Fig. 6. Motor current spectrum at $f_p = 40$ Hz

The transient and steady-state values of current of AC induction motor supplied by the frequency converter were recorded at f_c and f_p listed in table 2. Fast Fourier transform was applied for current to analyze spectrum of phase current. The current spectrum at $f_p = 10$ Hz is presented in Fig. 5. Two dominant groups of higher harmonics can be seen in the graph at 960 Hz and in surrounding of 2 kHz. The fundamental harmonic has frequency 10 Hz and it develops rotating magnetic field.

Harmonics with 960 Hz frequency matches the carrier frequency. Their amplitude reaches about 30% as compared to the fundamental harmonic. Harmonics with appear at the range of 2 kHz have amplitude approximately 20% of the fundamental and their frequency is repeatable to carrier frequency.

The spectrum of phase current in case when $f_p = 40$ Hz is presented in Fig. 6. Analysis of spectrum indicates the increase of spectrum components at frequencies close to fundamental harmonic frequency and at 4 kHz, which coincides with the carrier frequency.

Conclusions

Experimental investigation of variable speed drive with Space Vector Pulse Frequency Modulation and processing of steady state current curve with fast Fourier transform indicates that harmonics at inverter output of 40 Hz appear in the frequency range of 4,000 Hz with amplitude not exceeding 20% of fundamental. At inverter output 10 Hz, harmonics, repeatable to carrier frequency take place and their amplitude reduces with frequency.

Acknowledgement

The Lithuanian State Science and Studies Foundation supported this work under High-tech development program project B – 13/2007.

References

1. **Baskys A., Gobis V.** Generation of 3-phase voltage using space vector modulation method // Proc. of 9th European Conf. on Power Electronics and Applications. – Graz, Austria, Aug. 27-29, 2001.
2. **Bimal K. Bose.** Modern Power Electronics and AC Drives // New Jersey: Prentice Hall PTR, 2002. – P. 738.
3. **Rinkevičienė R., Lisauskas S.** Models of mechatronic systems with linear motors // Electronics and electrical engineering. – Kaunas: Technologija, 2003. – No. 4(46). – P. 69–73.
4. **Rinkevičienė R., Batkauskas V.** Modeling and investigation of vector controlled induction drive // Electronics and Electrical Engineering. ISSN 1392-1215. – Kaunas: Technologija, 2008. – No.1(81). – P. 53–56.

Received 2008 03 05

A. Petrovas, S. Lisauskas, V. Batkauskas, A. Baškys. Variable Speed Drive Supplied by the Voltage Formed using Special-purpose Algorithm // Electronics and Electrical Engineering. – Kaunas: Technologija, 2008. – No. 7(87). – P. 53–56.

Results of modeling and simulation of the AC induction motor drive supplied by the frequency converter with output voltage formed using special-purpose algorithm called SVPFM (Space Vector Pulse Frequency Modulation) are presented, where the carrier frequency in this method is proportional to the phase frequency. Simple and easy generation of the signals and consequently, the possibility to employ in frequency converter relatively simple and cheap microcontrollers is the main advantage of the SVPFM method over the commonly used SVPWM (Space Vector Pulse Width Modulation) method. Set of differential equations of the induction motor for simulation of AC motor – frequency converter interaction is derived. The motor model is developed in a stationary reference frame. Simulation results of motor speed and current transient are obtained and analyzed. The results of experimental investigation of the motor current spectrum are presented. Ill. 6, bibl. 4 (in English; summaries in English, Russian and Lithuanian).

A. Петровас, С. Лисаускас, В. Баткаускас, А. Башкис. Электропривод с переменной скоростью, питаемый напряжением сформированным при помощи специального алгоритма // Электроника и электротехника. – Каунас: Технология, 2008. – № 7(87). – С. 53–56.

Представлены результаты моделирования асинхронного электродвигателя, питаемого преобразователем частоты. Для формирования выходного напряжения в преобразователе использован специальный метод, назван SVPFM (метод модуляции частоты импульсов пространственного вектора), согласно которому несущая частота меняется пропорционально фазовой. Преимущество SVPFM метода по сравнению с широко распространённым SWPWM (метод модуляции ширины импульсов пространственного вектора) в том, что его реализация является менее сложной, поэтому в преобразователе частоты могут быть применены более простые микроконтроллеры. Выведена система дифференциальных уравнений асинхронного электродвигателя для неподвижной системы координат, при помощи которой построена математическая модель мотора для исследования взаимодействия мотора с преобразователем частоты. Приводятся и обсуждаются результаты моделирования переходных процессов скорости вращения и тока мотора. Также приводятся результаты экспериментального исследования спектра тока мотора. Ил. 6, библи. 4 (на английском языке; рефераты на английском, русском и литовском яз.)

A. Petrovas, S. Lisauskas, V. Batkauskas, A. Baškys. Kintamojo greičio elektros pavara maitinama įtampa suformuota specialiuoju algoritmu // Elektronika ir elektrotechnika. – Kaunas: Technologija, 2008. – Nr. 7(87). – P. 53–56.

Pateikti dažnio keitikliu maitinamo asinchroninio variklio modeliavimo rezultatai. Modeliuojant panaudotas specialusis išėjimo įtampos formavimo metodas, vadinamas SVPFM (erdvinio vektoriaus impulsų dažnio moduliavimo metodas), kurį taikant kartu su faziniu dažniu keičiasi ir nešlio dažnis. SWPFM metodas palyginti su visuotinai taikomu SWPWM (erdvinio vektoriaus impulsų trukmės moduliavimo metodu), yra pranašesnis tuo, kad jį paprasčiau realizuoti, todėl reikalavimai dažnio keitiklyje naudojamiems mikrovaldikliams yra mažesni. Sudaryta asinchroninį variklį aprašanti diferencialinių lygčių sistema, kuria sukurtas variklio Simulink modelis, skirtas variklio sąveikai su dažnio keitikliu tirti. Variklio modelis sudarytas nejudančioje koordinatinių sistemoje. Pateikiami ir analizuojami variklio greičio ir srovės pereinamųjų procesų modeliavimo rezultatai. Atliktas eksperimentinis variklio srovės spektro tyrimas. Il. 6, bibl. 4 (anglų kalba; santraukos anglų, rusų ir lietuvių k.).

DOI: 10.5755/j02.eie.11213