

High Speed C-V Converter

S. Sakalauskas

Department of Semiconductor Physics, Vilnius University,

Saulėtekio ave. 9-III, LT-10222, Vilnius, Lithuania, phone: +370 5 2366026, e-mail: stanislavas.sakalauskas@ff.vu.lt

Z. Vaitonis, R. Puras

Institute of Material Science and Applied Research, Vilnius University,

Saulėtekio ave. 9-III, LT-10222, Vilnius, Lithuania, phone: +370 5 2366033,

e-mail: zenonas.vaitonis@ff.vu.lt, romualdas.puras@ff.vu.lt

V. Bulbenkiene

Department of Informatics Engineering, Klaipėda University

Herkaus Manto str. 84, LT - 92294, Klaipėda, Lithuania, phone +370 46 398986, e-mail: violeta.bulbenkiene@ik.ku.lt

Introduction

A necessity to guaranty the high quality of the electronic components and devices, particularly those operating in the environment of ionizing radiation, requires from the manufacturers to put their best efforts into optimization of technological processes and increasing the effectiveness of its control. Depending on the properties and purpose of a device the control methods between the manufacturing operations may be various but the nondestructive and contactless ones are preferred. In particular, an electric capacitance and its dependence on the applied voltage, frequency, and temperature can provide plenty of information on electric, photoelectric, and other properties of semiconductor p-n junctions, metal-dielectric (silicon oxide)-semiconductor (MOS) structures, dielectric layers and coatings [1, 2, 3]. Well-established capacitance measurement methods and available measuring equipment ensure the high accuracy, however, it lacks speed, which limits its usability for measurement of capacitance-voltage characteristics.

Capacitance measurement with linearly varying voltage is used both in scientific laboratories and industrial instruments. The method, though it provides high speed of measurements, is scarcely discussed in literature and only a few papers are available on its applications for the measurement of capacitance-voltage characteristics in nonlinear elements [4, 5].

In this paper the theoretical and experimental results on electric circuit for the capacitance measurements with linearly varying voltage are presented. Also, the technique of elimination of parasitic capacitance, which allows increasing the measurement speed and reducing the dynamic errors, is discussed.

Theoretical results

Equivalent electric circuit of capacitance measuring device with linearly varying voltage is shown in Fig. 1. Here $U(t)=at$ is a source of linearly varying voltage, the internal resistance R of the device is connected series to measured capacitance C and resistor R_1 , which is shunted by parasitic capacitance C_1 . Useful signal – voltage $U_1(t)$ at follower output is expressed as [6]:

$$U_1(t)=aR_1C \left\{ 1 - \exp \left[- \frac{t}{(R+R_1)(C+C_1)} \right] \right\}. \quad (1)$$

The output voltage is directly proportional to the measured capacitance C (after transient process is over), i. e. the inner resistance of voltage source and parasitic capacitance has no influence on the value of voltage. R and C_1 have an influence during the transient period only. This perhaps is the biggest advantage of this method.

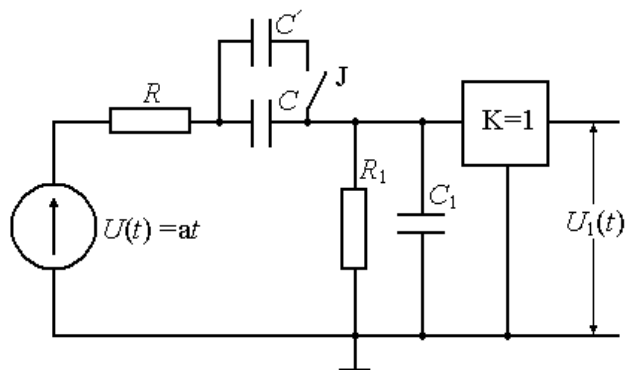

Fig. 1. Electric circuit corresponding to capacitance measuring device with linear varying voltage source

Peculiarities of such an electric circuit (Fig. 1) are only little explored for the case when a capacitor is replaced by a semiconductor p-n junction or MOS structure. Such a circuit is described by the nonlinear differential equation, which is difficult to solve analytically. That is why we chose to analyze the dependence of output voltage $U_1(t)$ on the measured capacitance when capacitance jumps at voltage $U(t) \neq 0$, i. e. when the capacitance is electrified by the electric charge Q_C , while the another capacitance C' with no electric charge is connected to it by switch J. We assume that at time instant $t = t_1$ the voltage of capacitance will be $U_C(t_1) \gg U_1(t_1)$ or $U_C(t_1) \approx at_1$ when the capacitance C' is connected parallel (we neglect R and C_1). For very short time interval the electric charge remains almost constant

$$Q_c = CU_c(t_1) = (C + C') \cdot U'_c(t_1) \quad (2)$$

and overall voltage on the parallel connected capacitances (due to the instantaneous recharging) will be:

$$U'_c(t_1) = \frac{C}{C + C'} U_c(t_1) = \frac{C}{C + C'} at_1. \quad (3)$$

According to (3) the voltage on parallel-connected capacitances will decrease at the moment $t = t_1 + \Delta t$ ($\Delta t \rightarrow 0$), while the output voltage will jump by a step (according to Kirchhoff rule). For further analysis we will use (1) expression.

Then the output voltage at time interval from zero to t_1 (influence of elements R and C_1 is omitted) will be:

$$U_1(t) = aR_1C \left[1 - \exp\left(-\frac{t}{R_1C}\right) \right]. \quad (4)$$

If capacitance C' is connected parallel at moment $t_1 \geq 5R_1C$ the output voltage will be:

$$U_1(t)_{t \geq t_1} = aR_1(C + C') + at_1 \frac{C'}{C + C'} \exp\left[-\frac{t}{R_1(C + C')}\right]. \quad (5)$$

Such voltage jump will occur always when additional capacitance is connected parallel, no matter if linear voltage source is increasing or decreasing. If the value of measured capacitance will decrease by step then the duration of transient output voltage will be determined by the remaining capacitance multiplied by R_1 , but no change in voltage will be present Fig. 2.

Such converter's output voltage jumps complicate the measuring process and reduce the measurement accuracy. However, these voltage jumps can be eliminated and the measurement accuracy can be increased by applying the numerical analysis methods.

Experiments with MOS structures show that the steep increase of output voltage are registered when the semiconductor depletion layer changes to inversion state (it is analogous to a very fast capacitance increasing). The amplitude and the area of the steep increase depend on velocity of linear voltage increase [5]. The areas related to physical phenomena in semiconductor structure are

considerably larger than those originating from the method's dynamic errors.

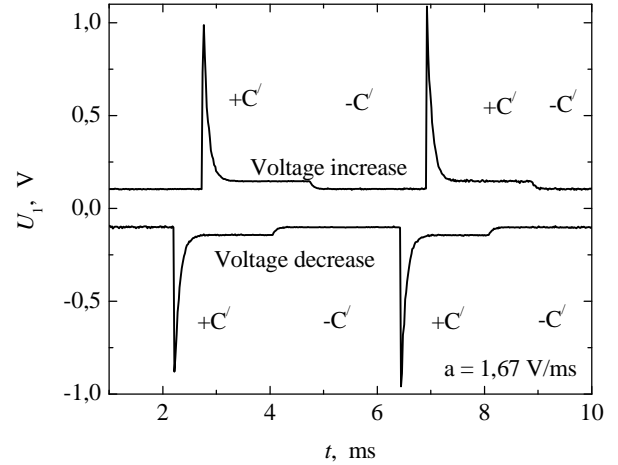

Fig. 2. Experimentally measured regularities of output voltage changes due to jump increase (+ C') or jump decrease $-C'$ of the measured capacitance

So with an aim to reduce the area due to method to δ -like function and to reduce transient time we will use known capacitance compensating method [7]. In Fig. 3 the electric diagram of such a capacitance-voltage converter is shown. It can be described by following equation system (we will use the Laplace transformation method):

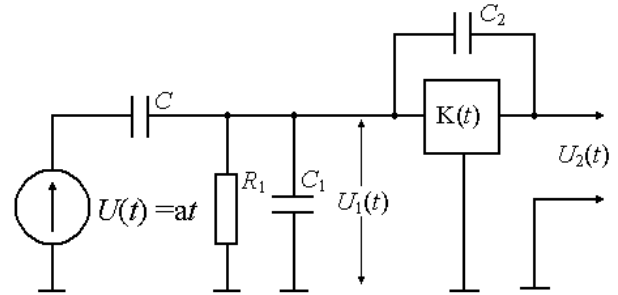

Fig. 3. Principal electric diagram of the capacitance-voltage converter

$$\begin{cases} [U(p) - U_1(p)]pC = \frac{U_1(p)(1 + R_1C_1p)}{R_1} \\ + [U_1(p) - U_2(p)]pC_2; \\ U_1(p) = \frac{U_2(p)}{K(p)}; \\ K(p) = \frac{K_0}{1 + \tau_0 p}. \end{cases} \quad (6)$$

The solution of the equation set with respect to the image of output voltage is (we use definitions $\tau = R_1(C + C_1 + C_2)$ and $\tau' = R_1C_2$):

$$U_2(p) = \frac{aR_1CK_0}{\tau_0\tau} \cdot \frac{1}{p^2 + p \frac{\tau_0 + \tau - \tau K_0}{\tau_0\tau} + \frac{1}{\tau_0\tau}}. \quad (7)$$

Second order differential equations have been thoroughly analyzed in the electric circuits' theory, thus it may be assumed that the shortest duration of non-periodical transient will be in the case when

$$\frac{\tau_0 + \tau - \tau'K_0}{2\sqrt{\tau_0\tau}} = 1 \quad (8)$$

or (assuming $\tau_0 \ll \tau$)

$$K_0 = 1 + \frac{C}{C_2} + \frac{C_1}{C_2}, \quad (9)$$

The output voltage will be

$$U_2(t) = aR_1CK_0 \left[1 - \left(1 + \frac{t}{\sqrt{\tau_0\tau}} \right) e^{-\left(t/\sqrt{\tau_0\tau} \right)} \right], \quad (10)$$

and after the transient process is over

$$U_2(t) = aR_1CK_0. \quad (11)$$

According to equations (10) and (11) the output voltage of capacitance-voltage converter is proportional to the measured capacitance and is independent on capacitance compensation ratio. The time of the transient, however, depends on the capacitance compensation ratio and it can be very short, but then the frequency passband of the amplifier must be as wide as possible, i.e. time constant τ_0 must be as short as possible. Thus, the transient time constant (expression (10)) may be lowered by factor of ten or even hundred, while the value of measured capacitance is not affected by compensation process. The latter is very important characteristic of discussed capacitance-voltage converter.

Experimental results

Theoretic conclusions were examined experimentally. C-V converter's prototype has been assembled using the operational amplifier TL071CP. The electric diagram is shown in Fig. 3 and obtained experimental results – in Fig. 4. Experimental results obtained on different capacitors matched very well the theoretical predictions. In the case of semiconductor p-n junction, the measurements were more complicated due to the capacitance decrease when the reverse voltage is applied. It complicates the process of capacitance compensation. The reason behind this is that the shortest transient is obtained for optimal compensation of the largest p-n junction capacitance. However, the overcompensation occurs (expression (9)) and self-excitation starts (see Fig.4, graphs 3) when voltage increases and capacitance decreases. Therefore, the optimal compensation is matched for the lower value of p-n structure's capacitance, in spite that it led to longer transients (see Fig.4, graph 2). Nevertheless, we note that the optimal compensation for the largest value of p-n structure's capacitance must be sought for the measurement of p-n junction's capacitance, and the transient feedback must be switched off at the end of the transient by disconnecting the capacitor C_2 by electronic

key. It would enable more precise measurement of the values of p-n junction's capacitance in low reverse voltage region as well as more precise estimation of distribution of dopants in the junction basis. These suggestions were supported by primary experiments, but it is necessary carry out further theoretical and experimental investigations for more precise results interpretation.

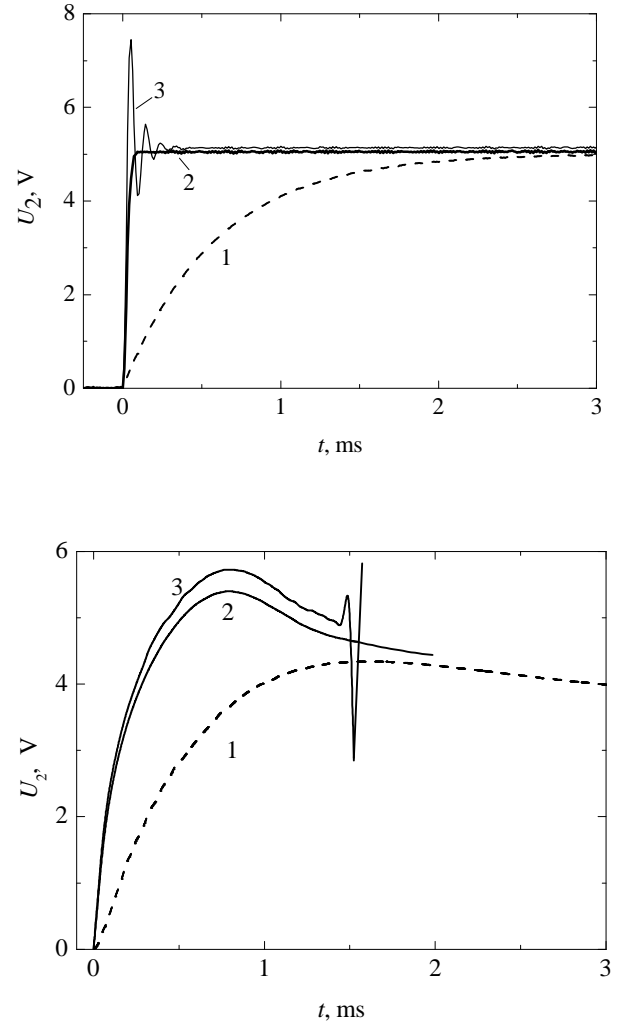

Fig. 4. Regularities of C-V converter's output voltage at measurement capacitance of capacitor (abovefigure) and capacitance of semiconductor p-n junction (below figure): 1- without compensation, 2- optimal compensation, 3- overcompensation

Conclusions

Theoretical analysis and experiments were carried out using a prototype of converter for electrical capacitance measurements by linearly varying voltage method allowed to make the following conclusions:

- converter's output voltage is proportional to the measured capacitance when the transient is over;
- output voltage is independent on parasitic capacitance and on linearly varying voltage source internal resistance;
- output voltage has high amplitude peak when the measured capacitance increases by jump no matter wether voltage increases or decreases (there is no output voltage amplitude jump when capacitance decreases);

-capacitance compensation enables to reduce transient process by factor of ten or more if measured capacitance is constant, and by several times if the latter varies (e.g. as in the case of p-n junction).

References

1. **Yaremchuk A. F.** A Contribution to the Theory of the C–V Technique for the Evaluation of Carrier–Concentration Profiles in Semiconductors // *Appl. Phys.*– 2005. – Vol. A80. – P. 881–883.
2. **McPherson M.** Capacitive Effects in Neutron–Irradiated Silicon Diodes // *Nucl. Instrum. and Meth. in Phys. Res.*– 2002.– Vol. A488.– P. 100–109.
3. **Campbell D., Chilingarov A., Sloan T.** Frequency and Temperature Dependence of the Depletion Voltage from CV

- Measurements for Irradiated Si Detectors // *Nucl. Instrum. and Meth. in Phys. Res.*– 2002.– Vol. A492.– P. 402–410.
4. **Zhang X., Ding K.** Field–Enhanced nonequilibrium C/V and I/V Characteristics of MOC Capacitor Under Linear Voltage Ramp Bias // *IEE Proc.–Circuits Devices Syst.*– 1996. – Vol. 143, No. 6. – P. 343–347.
 5. **Sakalauskas S., Vaitonis Z.** Dynamic C–V Characteristics of MOS Structures // *Lithuanian Journal of Physics.*– 2007. – Vol. 47, No. 4. – P. 451–456.
 6. **Sakalauskas S., Pūras R., Vaitonis Z.** Quasielektrostatic Converters in Materials’ Quality Control // *Ultragarsas.*– 2006. – No. 2 (59). – P. 55–58.
 7. **Sakalauskas S., Vaitonis Z., Pūras R.** Mikroelektroninio krūvio ketiklio jautrio didinimo būdas // *Elektronika ir elektrotechnika.* – 2005. – Nr. 1 (57). – P. 71–73.

Submitted for publication 2008 02 02

S. Sakalauskas, Z. Vaitonis, R. Pūras, V. Bulbenkiene. High Speed C-V Converter // Electronics and Electrical Engineering. – Kaunas: Technologija, 2008. – No. 6(86). – P. 73–76.

Theoretical analysis and experimental investigation of the method to measure capacitance and structure’s capacitance-voltage characteristics by means of linearly varying voltage showed a linear dependence between the output voltage and capacitance (when transient process is over). Whereas the duration of transient process is determined mainly by the value of measured capacitance multiplied by resistance, the transient duration may be reduced by lowering resistor’s value, though it decreases signal to noise ratio. We choose another solution – the compensation of electric capacitance, which very effectively reduces (by a factor of several tens) the transient duration and does not affect the relationship measured capacitance – output voltage. It increases the operation speed of capacitance-voltage converter. Ill. 4, bibl. 7 (in English; summaries in English, Russian and Lithuanian).

С. Сакалаускас, З. Вайтонис, Р. Пурас, В. Бульбенкене. Высокоскоростной преобразователь емкость-напряжение // Электроника и электротехника. – Каунас: Технология, 2008. – № 6(86). – С. 73–76.

Проведены теоретические и экспериментальные исследования показали, что метод с источником линейно изменяющегося напряжения для измерения электрической емкости компонентов и вольтфарадных характеристик структур обеспечивает, при завершении переходного процесса, прямую зависимость между емкостью и выходным напряжением. Так как длительность переходного процесса в основном определяется произведением величины измеряемой емкости на величину резистора, с которого снимается выходное напряжение, то уменьшение длительности переходного процесса может быть связано со снижением величины резистора, но это приводит к снижению соотношения сигнал–шум. Мы выбрали другой путь – компенсацию электрической емкости, которая очень эффективно (до несколько десятков раз) снижает длительность переходного процесса, однако не меняет характера зависимости между измеряемой емкостью и выходным напряжением, и очень увеличивает скорость действия преобразователя емкость–напряжение. Ил. 4, библи. 7 (на английском языке; рефераты на английском, русском и литовском).

S. Sakalauskas, Z. Vaitonis, R. Pūras, V. Bulbenkienė. Didelės spartos talpos ir įtampos keitiklis // Elektronika ir elektrotechnika. – Kaunas: Technologija, 2008. – Nr. 6(86). – P. 73–76.

Atlikti teoriniai ir eksperimentiniai tyrimai parodė, kad komponentų elektrinės talpos ir darinių voltfaradinių charakteristikų matavimo metodas su tiesiškai kintančios įtampos šaltiniu užtikrina, tiesioginį talpos ir išėjimo įtampos sąryšį pasibaigus pereinamajam procesui. Kadangi pereinamojo proceso trukmę daugiausiai lemia matuojamosios talpos ir rezistoriaus, kuriame gaunama išėjimo įtampa, verčių sandauga, tai trukmės mažinimas gali būti siejamas tik su rezistoriaus vertės mažinimu, tačiau tada mažėja signalo–triukšmo santykis. Pasirinktas kitas būdas – elektrinės talpos kompensavimas, kuris labai efektyviai (iki keliasdešimt kartų) sumažina pereinamojo proceso trukmę, tačiau nekeičia matuojamosios talpos ir išėjimo įtampos sąryšio pobūdžio, o tai labai padidina talpos ir įtampos keitiklio matavimo spartą. Il. 4, bibl. 7 (anglų kalba; santraukos anglų, rusų ir lietuvių k.).

