

Examination of Different Spread Spectrum Techniques for EMI Suppression in dc/dc Converters

J. Jankovskis, D. Stepins, S. Tjukovs, D. Pikulins

*Faculty of Electronics and Telecommunications, Riga Technical University,
 Azenes str. 12 – 407, Riga, LV-1048, Latvia, tel. +371 7 089 213; e-mail: jankovsk@rsf.rtu.lv*

Introduction

Within a few last decades power supply almost in all areas of electronics has evolved on a substantial scale from linear power regulators (being essentially bulky and heavy, with low power efficiency) to switch mode ones (considerably smaller and lighter, with high power efficiency). Unfortunately this transfer is accompanied by high increase of conducted and radiated electromagnetic noise as a consequence of power regulation method in itself – sharp switching process of current inherently is resulting in large amount of harmonics of fundamental switching frequency f_{sw} (even the use of lowest typical values, e.g. as low as several tens kHz for f_{sw} may initiate harmonics well in MHz region). Consequently the widespread use of switch mode power supply (SMPS) makes substantial contribution to energy saving but simultaneously considerably increases noises and thus intensifies electromagnetic interference (EMI) and electromagnetic compatibility (EMC) problems. Measures intended to match the noise to the allowed levels of EMI and EMC usually include the application of appropriate design of SMPS [1, 2] (e.g., the use of input and output filters, correct design of printed circuit boards, grounding, shielding, etc.) and proper organization of switching process (matching best wherever possible with soft-switching process versus hard-one incorporating rapid changes both of current i and voltage V on time t and thus resulting in high di/dt , dV/dt , and EMI noise [3]). Another successful concept along this line involves manipulations with f_{sw} – its value is changed by the action of low-frequency additional signal (periodic, random or chaotic). This in fact frequency modulation technique known as spread-spectrum, previously introduced and still developed for radio communications [4], currently broadens its scope in the field of SMPS as well but with different goal – reduction of EMI noise of power supply. Here used noise reduction principle is simple: highly annoying unmodulated switching process energy in the form of noise spikes concentrated mainly at fundamental frequency f_{sw} and its low-order harmonics versus less annoying same average noise energy in the shape of its more even

distribution – spreading around mentioned frequencies in the case of modulated switching (Fig.1). Despite the clearness of principle the details of modulated switching process are rather complex. Hence this approach now is an active area of research where fundamental investigations [5, 6] are accompanied by numerous examinations of specific important details.

In this study, the emphasis is on the experimental examination of the effectiveness of different modulation techniques used for switching frequency f_{sw} of dc/dc converters with the aim of EMI suppression in these SMPS but with combined concurrent control of possible undesirable effects of the modulation on quality of voltage on the load (namely, excess output voltage ripples).

Switching frequency modulation techniques

Switching frequency modulation techniques (SFMT) can basically be classified into 3 major types: periodic (PSFMT), randomized (RSFMT) and chaotic (CSFMT) [9]. All the methods have their advantages and disadvantages, the details of which we try to find out experimentally.

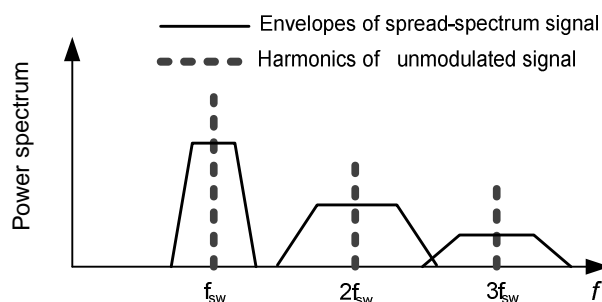

Fig.1. Comparison of switching signal as unmodulated and a spread-spectrum one

Although all the harmonics of a switching signal are affected by frequency modulation (FM) process (as it also shown in Fig.1), let us consider for simplicity the modulation only on fundamental harmonic of (switching) frequency f_{sw} . In general, frequency modulated sine signal can be described by formula:

$$s_m(t) = A_c \cos(2\pi f_c t + \theta(t)), \quad (1)$$

where A_c and f_c (here in fact as f_{sw}) is the amplitude and frequency of carrier signal respectively; $\theta(t)$ is time dependent phase angle, according to

$$\theta(t) = 2\pi \int_0^t k_f \cdot m(\tau) d\tau, \quad (2)$$

where $m(\tau)$ is a modulating signal; k_f is the scaling coefficient of the frequency deviation Δf_c at given amplitude of a modulating signal A_m , $k_f = \Delta f_c / A_m$.

For a sinusoidal switching frequency modulation technique (1) is as follows:

$$s_{ssfmi}(t) = A_c \cos(2\pi f_c t + \frac{k_f A_m}{f_m} \sin(2\pi f_m t)),$$

where f_m – frequency of the modulating signal.

In the case of PSFMT two useful parameters describing characteristics of $s_m(t)$ are: modulation index, β , and the rate of modulation, δ :

$$\beta = \frac{k_f A_m}{f_m} = \frac{\Delta f_c}{f_m} = \frac{\Delta f_{sw}}{f_m}, \quad (3)$$

$$\delta = \frac{\Delta f_{sw}}{f_{sw}}. \quad (4)$$

When rectangular pulses sequence is affected, for instance, by PSFMT, the bandwidth B_h where a certain harmonic is spread up increases with harmonic number h , and can be approximated as follows [8]:

$$B_h = 2(h\beta + 1) \cdot f_m.$$

That means that at higher harmonics the bands B_h of adjacent harmonics may overlap (as it is also shown in Fig. 1. for the second and the third harmonics), thus some undesirable effects may occur.

Suppression of f_{sw} and its harmonics increases, when β increases [10]. High-order harmonics attenuation effect is more pronounced than low-order ones, when no significant overlapping effect of side bands exists [10].

In this study $m(\tau)$ as random or chaotic signal is also used. For these signals randomness level is usually used instead of modulation index [12]:

$$R = \frac{T_2 - T_1}{T_{sw}}, \quad (5)$$

where T_2 is the maximum possible switching period; T_1 is the minimum possible switching period; T_{sw} is $1/f_{sw}$ – nominal switching period.

Experimental setup

In order to examine different FM techniques, the dsPICDEM™ SMPS Buck Development Board from Microchip is used. The Board allows rapid development of buck converters using dsPIC30F2020 Digital Signal

Controllers (DSC). The DSC is designed specially for application in SMPS, thus it provides the necessary memory and peripherals for A/D conversion, PWM generation and general purpose I/O, precluding the need to perform these functions in external circuitry. Although the board contains two independent buck converters, only one was used in experiments. The board allows easy and quickly reprogramming of the controller to evaluate different modulation techniques on the one test plant. The DSC contains the PWM module, which includes set of built in features that improve the process of software development [11].

Simplified schematic diagram of the experimental setup is shown in Fig.2. The buck converter operating in open-loop mode is tested with $R_{load}=6\Omega$, input voltage $V_{in}=6.5V$, $f_{sw}=300kHz$ and the duty cycle of 0.5. Calculated cut-off frequency of the output filter is approximately 550 Hz.

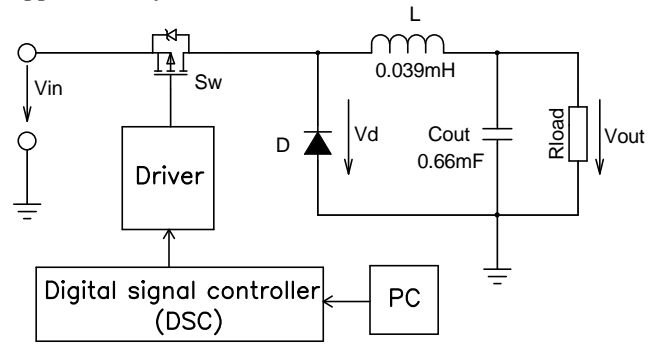

Fig. 2. Simplified schematic diagram of tested setup

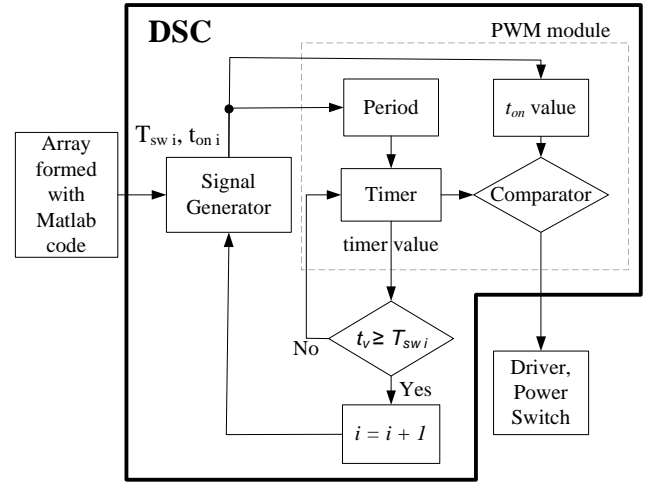

Fig. 3. PWM signal forming algorithm implemented in DSC

Block diagram of the algorithm implemented in DSC is shown in Fig. 3. PWM module contains build in timer/counter circuit and comparator. Timer counts from zero to period value $T_{sw(i)}$. When timer value reaches $T_{sw(i)}$ (the end of PWM period), new values of $T_{sw(i+1)}$ and $t_{on(i+1)} = T_{sw(i+1)}/2$ are generated by Signal Generator and fed into PWM block. Then timer resets. Timer value is constantly compared with t_{on} by comparator and while $t_{on} < \text{timer value}$ power switch is open, otherwise it is closed. The Buck converter thus operates at frequency $1/T_{sw}$ with Duty Cycle

$t_{on}/T_{sw}=0.5$. In this way PWM control signal's frequency is changed every PWM cycle.

with increasing δ . This means that there is trade-off between EMI attenuation and ripples of V_{out} .

Table 1. Main parameters of FM techniques under investigation

| Switching modulation techniques | Abbreviation | f_{sw} , kHz | Δf_{sw} , kHz | $\Delta f_{sw}/f_{sw}$, % | Additional characteristics | | |
|---------------------------------|--------------|----------------|-----------------------|----------------------------|---|--|--|
| Sinusoidal | SSFMT1 | 300 | 7.5;15;30;45;60 | 2.5;5;10;15;20 | $f_m=2\text{kHz}$ | | |
| | SSFMT2 | | | | $f_m=5\text{kHz}$ | | |
| Pseudo-random | PRSFMT1 | | | | uniform distribution of $m(\tau)$ | | |
| | PRSFMT2 | | | | normal distribution of $m(\tau)$ | | |
| Pseudo-chaotic | PCSFMT | | | | Voltage on LC energy storage elements from Chua's circuit [9] under double-scroll chaos operation mode with oscillation frequency of 4kHz | | |

As we see from Fig. 3 new values of T_{sw} and t_{on} , are determined by Signal Generator (Chua circuit, Uniform Random Number Generator, Normal Random Number Generator, Sine Wave generator), which in point of fact is a data array, which contains 2000 elements and is written into the DSC Flash memory.

Arrays for different experiments are formed with the help of Matlab code, where appropriate modulating signal $m(\tau)$ parameters (probability density function, randomness level for random signals and modulation index, modulating signal frequency for sine wave) can be set up.

Taking into account the fact that values of random and chaotic modulating signals are recorded to arrays and their pattern repeats after a certain number of PWM cycles, actually, pseudo-random and pseudo-chaotic SFMT are examined in this research.

Results and their discussions

For comparative examination of influence of different switching frequency f_{sw} modulation techniques on EMI reduction, power spectra of the freewheeling diode voltage V_d (Fig. 2) of the buck converter was measured by using spectrum analyser (Agilent N9320A) with RBW=300Hz. FM techniques examined and their parameters are tabulated in Table 1. The power spectra are analysed for different modulation rates δ ; Δf_{sw} is changed from 0 to 60 kHz.

The individual values of attenuation for the first harmonic of unmodulated V_d for different Δf_{sw} values are depicted in Fig. 4. The power spectra of the investigated FM techniques for the definite value of Δf_{sw} are shown in Fig. 6.

To investigate undesirable possible side effects in the form of excess output voltage ripple, V_{out} waveforms are recorded by using a digital oscilloscope. Measured peak-to-peak ripples (V_{p-p}) of V_{out} are shown in Fig. 5. (V_{p-p} of the output voltage for the unmodulated converter is 17.4 mV.)

As expected from the theory [8] attenuation of the first harmonic and higher-order ones of V_d increases with increasing δ , and consequently, R or β , for all the modulation techniques under investigation. Suppression of high-order harmonics is more effective than the low-order ones, as it can also be observed in Fig. 6, when comparing the third and the first harmonics attenuation with each other. Unfortunately, output voltage ripples also increase

However, there is no significant improvements in discrete harmonics suppression when $\beta > 20$ for SSFMT1 and SSFMT2, $R > 0.3$ for PRSFMT1 and PRSFMT2, and $R > 0.4$ for PCSFMT.

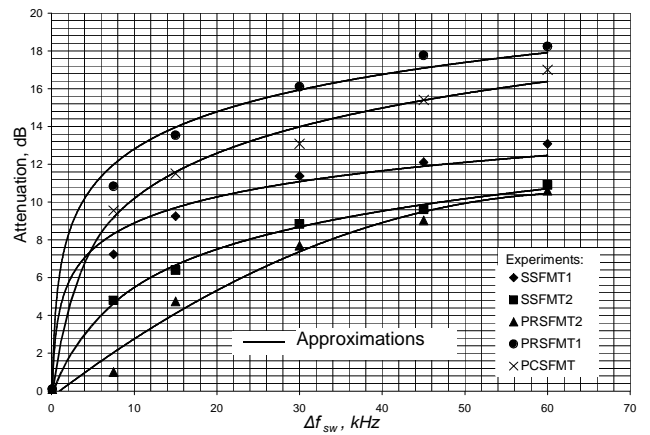

Fig. 4. Attenuation trends of the first harmonic of V_d with increasing Δf_{sw} , based on measured values

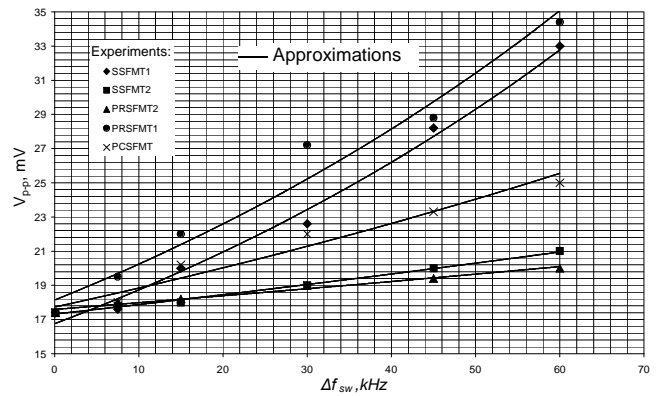

Fig. 5. Measured output voltage V_{p-p} versus Δf_{sw}

Analysis of the Fig. 4 and Fig. 5 reveals that PRSFMT1 and PCSFMT show better attenuation of the first harmonic, but PCSFMT gives smaller V_{p-p} (about 9.4 mV smaller than PRSFMT1, when $\Delta f_{sw}=60\text{kHz}$). This is due to the fact that chaotic modulation introduces less low-frequency spectral components at the output of the converter than random FM technique with uniform probability distribution of $m(\tau)$ [9].

SSFMT2 and PRSFMT2 give smaller V_{p-p} than the other techniques under the investigation, but SSFMT2 has

better suppression of the first harmonic than the PRSFMT2 when Δf_{sw} is in range 0...30 kHz.

Although SSFMT1 gives better suppression of the harmonics than the SSFMT2 and PRSFMT2, this method has rather large output voltage ripples when $\Delta f_{sw} > 30\text{kHz}$. Besides, output voltage ripples have distinct low-frequency spectral component of modulating frequency $f_m = 2\text{kHz}$ (in fact, an unwanted demodulation of frequency modulated signal takes place). Although V_d does not have this component at its spectrum, this is due to appearance of undesirable effects caused by the frequency modulation in the buck converter. Of course, this spectral component can be reduced by increasing the output filter capacitance (it would result in better attenuation) or increasing f_m . But the first will inevitably lead to increasing converter dimensions; the second one will lead to decreasing β and in its turn to less EMI attenuation.

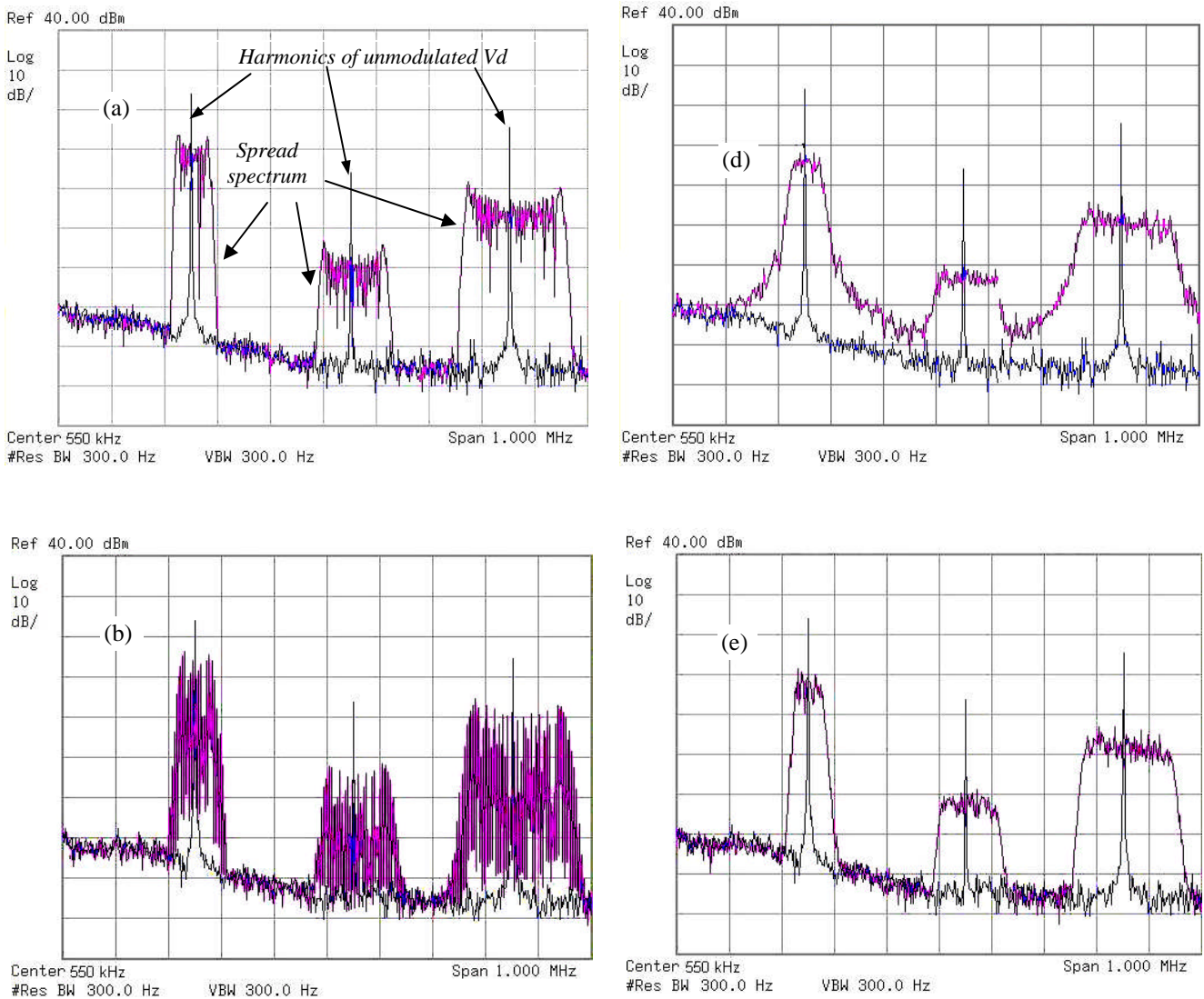

Fig. 6. Experimental power spectra of V_d for FM techniques examined with $\Delta f_{sw} = 30\text{ kHz}$. (a) SSFMT1. (b) SSFMT2. (c) PRSFMT2. (d) PRSFMT1. (e) PCSFMT. Comparison of Fig.6(a,b,e) with Fig.6(c,d) reveals that for pseudo-random SFMT EMI is spread along the whole frequency spectrum more evenly, while in the case of sinusoidal and pseudo-chaotic SFMT there are no distinct additional spectrum components between adjacent bands

Conclusion

Sinusoidal, pseudo-random and pseudo-chaotic switching frequency modulation techniques have been incorporated into the switching control of the digitally-controlled buck converter. All the techniques have been studied experimentally and compared with each other. The experiments prove that there is trade-off between discrete harmonics suppression and output voltage ripples. Pseudo-chaotic FM technique is most attractive spread-spectrum technique, when the trade-off is of significance. Pseudo-random FM technique with uniform probability distribution of modulating signal shows better attenuation of discrete harmonics than the other FM techniques examined but also has large output voltage ripples. That is why this technique can be used for applications, where high EMI attenuation with small switching frequency deviations is of importance. When small output voltage ripples are desirable, using sinusoidal FM technique with properly selected modulation frequency and switching frequency deviation should be considered.

References

1. **Wenston D.A.** Electromagnetic Compatibility: Principles and Application. 2nd Ed., Marcel Dekker, Inc. – 2001.
2. **Mardiguian M.** Controlling Radiated Emissions by Design. 2nd Ed., Kluwer Acad. Publ. – 2001.
3. **Redl R.** Electromagnetic Environmental Impact of Power Electronics Equipment // Proc. IEEE. – 2001. – Vol. 86, No.6. – P. 926–938.

4. **Schilling D.L., Pickholtz R.L., Milstein L.B.** Spread spectrum goes commercial // IEEE Spectrum. – 1990. – Vol. 27, No. 8. – P. 40–44.
5. **Banerjee S., Verghese G.C.** Nonlinear Phenomena in Power Electronics. – IEEE Press, 2001. – 441 p.
6. **Tse. C.K.** Complex Behavior of Switching Power Converters. – CRC Press LCC, 2004. – 262 p.
7. **Stanković A.M., Lev-Ari H.** Randomized Modulation in Power Electronic Converters // Proc. IEEE. – 2002. – Vol. 90, No. 5. – P. 782 – 799.
8. **Tse K.K., Chung H.S., Hui S.Y., So H.C.** Comparative Study of Carrier-Frequency Modulation Techniques for Conducted EMI Suppression in PWM Converters // IEEE Trans. on Industrial Electronics. – 2002. – Vol. 49, No. 3. – P. 618–627.
9. **Tse K.K., Chung H.S., Hui S.Y., So H.C.** An Evaluation of the Spectral Characteristics of Switching Converters with Chaotic Carrier-Frequency Modulation // IEEE Trans. on Industrial Electronics. – 2003. – Vol.50, No.1. – P. 171–181.
10. **Gonzalez D., Balcells J., Santolaria A., Bunetel J.C., Gago J., Magnon D., Brehaut S.** Conducted EMI Reduction in Power Converters by Means of Periodic Switching Frequency Modulation // IEEE Trans. on Power Electronics. – 2007. – Vol.22, No.6. – P. 2271–2281.
11. **dsPICDEM™ SMPS Buck Development Board User's Guide.** – Microchip Technology Inc., 2006. – P. 50.
12. **Stankovic A.M., Verghese G.C., Perreault D.J.** Analysis and Synthesis of Randomized Modulation Schemes for Power Converters // IEEE Trans. on Power Electronics. – 1995. – Vol.10, No.6, P. 680–693.

Submitted for publication 2008 03 12

J. Jankovskis, D. Stepins, S. Tjukovs, D. Pikulins. Examination of Different Spread Spectrum Techniques for EMI Suppression in dc/dc Converters // Electronics and Electrical Engineering. – Kaunas: Technologija, 2008. – No. 6(86). – P. 60–64.

Examination of different switching frequency modulation techniques (SFMT) for electromagnetic interference (EMI) suppression in dc/dc power converters is presented. The techniques under investigation are sinusoidal (with modulating frequencies 2 kHz and 5 kHz), pseudo-random (with uniform and normal probability distributions of modulating signal) and pseudo-chaotic SFMT. All the techniques are applied to digitally-controlled buck converter of Microchip dsPICDEM SMPS Buck Development Board. Free-wheeling diode voltage of the buck converter operating at switching frequency of 300 kHz and exposed to switching frequency deviation ranging from 0 to 60 kHz is analyzed in order to show effectiveness of such techniques in terms of EMI attenuation. Concerning with possible undesirable side effects in the form of excessive output voltage ripples, the experiments are accompanied by output voltage control of the converter. Analysis of the results obtained reveals that there is need for trade-off between EMI attenuation and output voltage ripples. The pseudo-chaotic SFMT shows the best results from the standpoint of this trade-off. Pseudo-random SFMT with uniform probability distribution of modulating signal gives better EMI attenuation than the other techniques, but output voltage ripples are also larger. That is why this technique can be used for applications, where high EMI attenuation by use of small switching frequency deviations is of primary importance. Ill. 6, bibl.12 (In English; summaries in English, Russian and Lithuanian).

Я. Янковский, Д. Степин, С. Тюков, Д. Пикюлин. Исследование методов расширенного спектра для ослабления электромагнитных помех в преобразователях постоянного тока // Электроника и электротехника. – Каунас: Технологія, 2008. – № 6(86). – С. 60–64.

Представлено исследование различных методов модуляции частоты коммутации (ММЧК) для ослабления электромагнитных помех (ЭП) в импульсных преобразователях постоянного тока. Исследуемыми методами являются синусоидальный (с частотами модуляции 2 кГц и 5 кГц), псевдослучайный (с равномерной и нормальной плотностью распределения вероятности модулирующего колебания), а также псевдохаотический. Все эти методы применены к понижающему преобразователю платы dsPICDEM SMPS Buck Development Board фирмы Microchip. С целью изучения эффективности применения данных методов модуляции, анализировалось напряжение на разрядном диоде преобразователя работающего на частоте коммутации 300 кГц с различными значениями ее девиации в диапазоне от 0 до 60 кГц. Одновременно измерялись пульсации выходного напряжения. Анализ результатов измерений для всех видов модуляции показал, что чем лучше ослабление ЭП, тем больше пульсации выходного напряжения. Псевдохаотический ММЧК даёт лучшие результаты с точки зрения обоих. Псевдослучайный ММЧК с равномерной плотностью распределения вероятности имеет как более высокие пульсации, так и ослабление. Поэтому данный метод можно использовать тогда, когда высокое ослабление ЭП должно быть достигнуто при малых девиациях частоты коммутации. Ил. 6, библи. 12 (на английском языке; рефераты на английском, русском и литовском яз.).

J. Jankovskis, D. Stepins, S. Tjukovs, D. Pikulins. Praplainto spekro elektromagnetinių triukšmų slopinimo nuolatinės srovės keitikliuose metodų tyrimas // Elektronika ir elektrotechnika. – Kaunas: Technologija, 2008. – Nr. 6(86). – P. 60–64.

Išnagrinėti moduliacijos dažnio komutacijos metodai: sinusoidinis (kai moduliacijos dažniai yra 2 kHz ir 5 kHz), pseudoatsitiktinis (esant vienodam ir normaliam tikimybės moduluotų signalų dalijimui) ir pseudochaotinis. Gauti rezultatai rodo, kad maitinimo įtampą reikia reguliuoti. Pseudochaotinio tyrimo rezultatai gaunami geriausi. Pseudoatsitiktiniu būdu, esant vienodam tikimybės dalijimui, signalas moduluojamas geriau. Il. 6, bibl. 12 (anglų kalba; santraukos anglų, rusų ir lietuvių k.).

DOI: 10.5755/j02.eie.11185