

Modelling of Intelligent Multi-Agent based E-health Care System for People with Movement Disabilities

A. A. Bielskis, V. Denisovas, D. Drungilas, G. Gričius, O. Ramašauskas

Department of Informatics, University of Klaipėda,

Manto str. 84, LT-92294 Klaipėda, Lithuania, phone: +370 46 398820;

e-mail: {bielskis, vitalij, gediminas, olegas}@ik.ku.lt

Introduction

In creating of adaptive user-friendly e-health care service for people with movement disabilities, human's affect sensing may be helpful. Being able both to provide an intelligent accident preventive robot-based support for people with movement disabilities and to include affect sensing in Human Computer Interaction (HCI), Human-Robot Interaction (HRI), and Computer Mediated Communication (CMC), such system depends upon the possibility of extracting emotion without interrupting the user during HCI, HRI, or CMC [1, and 2].

The features of continuous physiological activity of disabled person are becoming accessible by use of intelligent bio-sensors coupled with computers. Such sensors provide information about the wearer's physical state or behavior. They can gather data in a continuous way without having to interrupt the user and may include sensors of: Galvanic Skin Response (GSR) or Electrodermal Activity (EDA), Blood Volume Pulse (BVP), Electrocardiogram (ECG), Respiration, Electromyogram (EMG), Body temperature (BT), and Facial Image Comparison (FIC). Galvanic Skin Response, the GSR, is a measure of the skin's conductance between two electrodes that apply a safe, imperceptibly tiny voltage across the skin of subject's fingers or toes. An individual's baseline skin conductance will vary for many reasons, including gender, diet, skin type and situation. When a subject is startled or experiences anxiety, there will be a fast increase in the skin's conductance (a period of seconds) due to increased activity in the sweat glands (unless the glands are saturated with sweat). After a startle, the skin's conductance will decrease naturally due to reabsorption. Sweat gland activity increases the skin's capacity to conduct the current passing through it and changes in the skin conductance reflect changes in the level of arousal in the sympathetic nervous system. A number of wearable systems have been proposed with integrated wireless transmission, GPS (Global Positioning System) sensor, and local processing. Commercial systems

are also becoming available. For example, CardioNet provides a remote heart monitoring system where ECG signals are transmitted to a PDA (Personal Digital Assistant) and then routed to the central server by using the cellular network. Pentland [1] recently presented the wearable MIThril system where ECG data, GPS position, skin temperature and galvanic skin response can be captured by a PDA. Most this type hardware platforms are designed for network research, environment monitoring or tracking applications, such as Berkeley's Mica2 and Telos, ETH's BTnodes, Intel's iMote and UCC's DSYS25. Although there are a number of context aware sensing platforms such as the SmartITs and the MITes (see Tapia E. M., Marmasse N., Intille S. S., Larson K. MITes: Wireless Portable Sensors for Studying Behavior // Proceedings of the UbiComp, Sept. 2004), the incorporation of physiological sensors will require major redesign of the hardware platform.

To facilitate the research and development of BSN (Body Sensor Network), a BSN hardware platform has to be designed and developed. In this paper, we are describing some aspects of constructing of human-computer confluence by proposing a model of Intelligent Multi-Agent-Based E-Health and E-Social Care System for People with Movement Disabilities.

Computer mediated communication in the system

This paper presents some aspects of application of remote ECG, body temperature and EDA measurements used in providing multi-agent based e-health and e-social care assistance for people with movement disabilities by (see Drungilas D., Gričius G., Lotužis K., Šliamin A., Bielskis A. A. Modeling of Multi-Agent-Based E-Social Care System for People with Movement Disabilities: Course Group Project, 2007. http://e-laboratorija.lietuvoje.info/index.php?int_pageId=37, and [5]). In the proposed model of Fig. 1, two adaptive moving wheelchair-type robots are remotely communicating with two wearable human's affect sensing bio-robots. To capture towards e-social and e-health care context relevant episodes based on humans affect stages

[2], the context aware sensors are incorporated into the design of the Human's Arousal Recognition Module's (HARM- x) for every disabled individual, and the local Intelligent Decision Making Module's (IDMM- x) for every intelligent social care providing robot is used for multi-sensor data fusion before transmitting the data to the Remote Central Server (RCS) to minimize the TCP/IP (UDP) bandwidth usage.

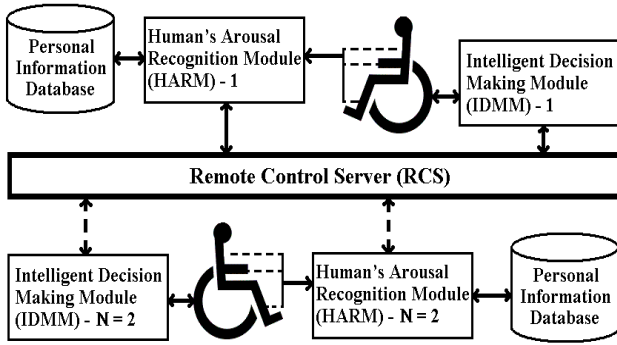

Fig. 1. Computer Mediated Communication model of the system

The healthy human's ECG graph on Fig. 2a is described by: 6 curves, the P, Q, R, S, T, and U, the amplitudes measured in mV of those curves, the Pa , Qa , Ra , Sa , Ta , and Ua , respectively, the durations of those curves measured in sec , the Pd , Qd , Rd , Sd , Td , and Ud , respectively, and a hearth rate interval between two adjacent P-waves measured in sec , the Hr .

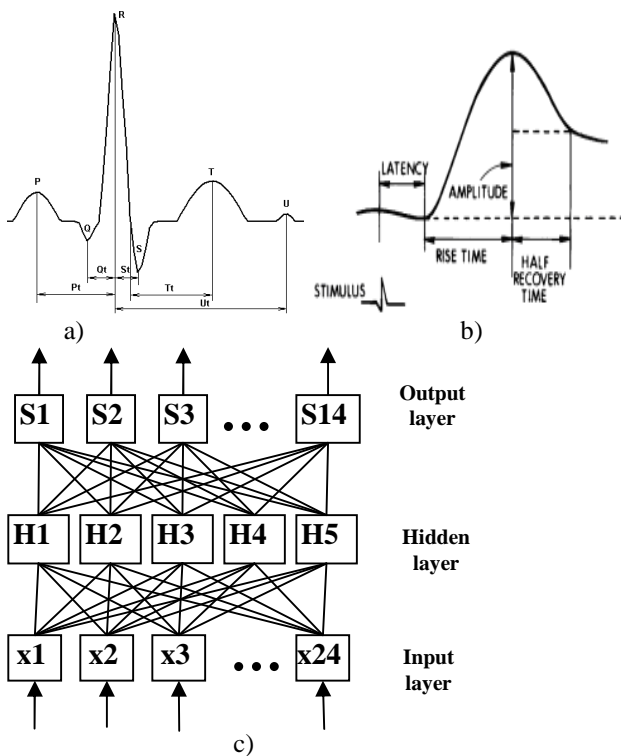

Fig. 2. Elements to recognizing given e-health aware state of individual who is waiting of an appropriate social care assistants in the system: a) Graphs to providing typical parameters of healthy human's ECG; b) EDA response; c) Artificial neural network (ANN) to recognizing given e-health aware state of an individual

Arousal Recognition Module (HARM) for every disabled individual, and the local Intelligent Decision Making Module (IDMM) for every intelligent social care providing robot is used for multi-sensor data fusion before transmitting the data to the Remote Central Server (RCS) to minimize the bandwidth usage.

There are shown typical parameters of healthy human's electrocardiogram (see the ECG graph on Fig. 2a), electro dermal activity (see the EDA graph on Fig. 2b), and artificial neural network (ANN) to recognizing given e-health aware state of individual (see block-diagram on Fig. 2c). The EDA parameters are as follows: the latency (Lat) which is the amount of time between the stimulus and the rise of the wave, the rise time (RT) which shows how long it takes for the skin conductance to shoot up to it's peak; the amplitude (A) which is the height of the skin conductance response (SCR), and the half recovery time (hrt) which is the amount of time it takes for the wave to fall back to half it's amplitude. Body temperature parameters are: t – temperature in *Degree Centigrade*, and dt – temperature change in *Degree Centigrade*. The artificial neural network (ANN) of Fig. 3 was used for recognition of state of an individual who may be taking part in the model. The database was created to describing the following 14 states of an individual represented by parameters: *Healthy, VeryGoodCondition, GoodCondition, NormalCondition, BadCondition, CriticalCondition, Happy, Sad, Angry, Fear, Surprised, Disgust, Sleepiness, and Calmness*. The multi-layer perceptron of Fig. 2c was used: with 24 neurons in an input layer to describing of parameters: 18 of ECG, 4 of EDA, and 2 of body temperature; with 5 neurons, the $H1, H2, \dots, H5$, of hidden layer, and with 14 neurons of output layer, the $S1, S2, \dots, S14$, to describing of human's states mentioned above. To examine the statistical significance of the mean value differences of the control sample, a multivariate analysis of variance (MANOVA) with repeated measures was used. Experimental data was generated for 15 cases of human e-health aware states each of which is expressed by 14th order vector to representing output data of 14 neurons of ANN shown on Fig. 2c. For each of 15 cases, there were generated the following number of 24th order data vectors: 100 vectors for learning and 100 vectors for training of ANN. By using R package, the user's state recognition neural network was constructed, learned, trained, and data was generated to representing of selected 15 independent states of given individual. Coordinates of each 14th order state vector are expressed by real numbers from 0 to 1 to representing each parameter of given state. Results of statistical multivariate analysis of variance of ANN prognoses in comparison with 15 typical user's state vectors are given in Table 1. Small values of deviation of each coordinate show good matching of prognoses with typical values.

Table 1. Standard deviation of user's state prognoses

S1	S2	S3	S4	S5	S6	S7
0.0216	0.0218	0.0048	0.0201	0.0061	0.0069	0.0038
S8	S9	S10	S11	S12	S13	S14
0.0163	0.0374	0.0149	0.0263	0.02	0.0138	0.0234

outputs the result of the product representing one fuzzy control rule. It takes two inputs, one from nodes $A1-A4$ and the other from nodes $B1-B3$ of layer 2. Nodes $A1-A4$ defines the membership values for the motor speed error and nodes $B1-B3$ define the membership values for the change in speed error. Accordingly, there are 12 nodes in layer 3 to form a fuzzy rule base for two input variables, with four linguistic variables for the input motor speed error $e(k)$ and three linguistic variables for the input change in motor speed change error $\delta e(k)$.

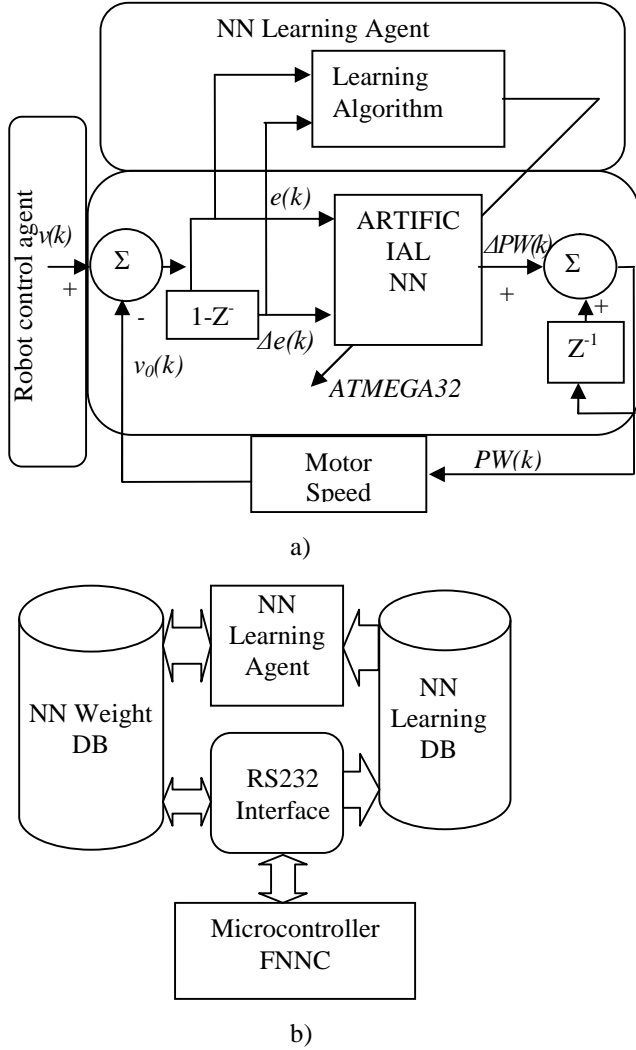

Fig. 4. Multi-agent based adaptive robot motor speed control system: a) Modified agent based adaptive FNNC-type DC motor speed controller [3], b) Agent-based NN learning system

The input/output links of layer 3 define the preconditions and the outcome of the rule nodes, respectively. The outcome is the strength applied to the evaluation of the effect defined for each particular rule. The output of neuron k in layer 3 is obtained as $O_{3k} = W_{3jk} * y_{3j}$, where y_{3j} represents the j^{th} input to the node of layer 3 and W_{3jk} is assumed to be unity. Neurons in the output membership Layer 4 represent fuzzy sets used in the consequent fuzzy rules. An output membership neuron receives inputs from corresponding fuzzy rule neurons and combines them by using the fuzzy operation union. This was implemented by the maximum function. Layer 4 acts

upon the output of layer 3 multiplied by the connecting weights. These link weights represent the output action of the rule nodes evaluated by layer 3, and the output is given $O_{4m} = \max(O_{3k} * W_{km})$, where the count of k depends on the links from layer 3 to the particular m^{th} output in layer 4 and the link weight W_{km} is the output action of the m^{th} output associated with the k^{th} rule. This level is essential in ensuring the system's stability and allowing a smooth control action. Layer 5 is the output layer and acts as a defuzzifier. The single node in this layer takes the output fuzzy sets clipped by the respective integrated firing strengths and combines them into a single fuzzy set.

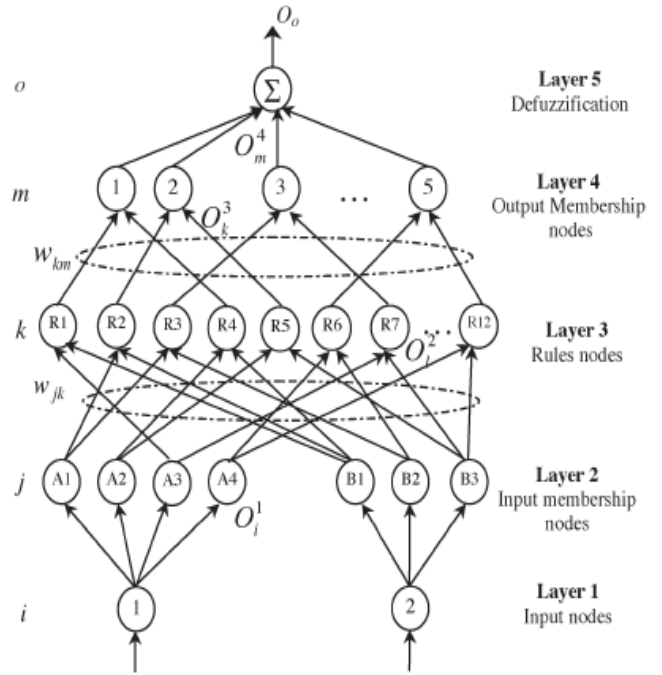

Fig. 5. Architecture of the neural-fuzzy controller [3]

The output of the neuro-fuzzy system is crisp, and thus a combined output fuzzy set must be defuzzified. The sum-product composition method was used. It calculates the crisp output as the weighted average of the cancroids of all output membership functions as $O_{5o} = \text{Sum}(O_{4m} * a_{cm} * b_{cm}) / \text{Sum}(O_{4m} * b_{cm})$, where a_{cm} and b_{cm} for $m = 1, \dots, 5$ are the centres and widths of the output fuzzy sets, respectively. The values for the b_{cm} 's were chosen to be unity. This scaled output corresponds to the control signal (percent duty cycle) to be applied to maintain the motor speed at a constant value. The only weights that are trained are those between layers 3 and layer 4 of Fig. 5. The back-propagation network is used to train the weights of this layer. The weights of the neural network were trained offline by using an open source type R -programming environment before they were used in the experimental by applying the learning algorithm from [7]:

Step (1): Calculate the error for the change in the control signal (duty cycle) for ATmega32-based microcontroller as $E_o = T_o - O_5$, where E_o , T_o , and O_5 are the output error, the target control signal, and the actual control signal;

Step (2): Calculate the error gradient $\delta_m = (T_o - O_{5o}) * (\text{Sum}(O_{4j}(a_{cm} - a_{cj})$ for $j = 1$ to $m-1$ and $j <> m) /$

$Sum(O_{aj} \text{ for } j = 1 \text{ to } m) * 2$, where a_{Ci} for $i = 1..5$ are the centres of the output fuzzy sets and O_{aj} is the firing strength from node j in layer 4;

Step (3): Calculate the weight correction $\Delta_{w_{km}} = \eta \delta_m O_{3k}$ to increasing the learning rate. Here Sejnowski – Rosenberg updating mechanism was used, which takes into account the effect of past weight, changes on the current direction of the movement in the weight space. This is given by $\Delta_{w_{km}}(t) = \eta(1 - \alpha)\delta_m O_{3m} + \alpha\Delta_{w_{km}}(t - 1)$, where α is a smoothing coefficient in the range of $0..1,0$ and η is the learning rate;

Step (4): Update the weights $w_{km}(t + 1) = w_{km}(t) + \Delta_{w_{km}}(t)$, where t is the iteration number. The weights linking the rule layer (layer 3) and the output membership layer (layer 4) are trained to capture the system dynamics and therefore minimize the ripples around the operating point.

Human computer interaction in the system

Human Computer Interaction (HCI) in the system realized in providing of necessary e-health care support actions for user1 and user2 discovered in the *Personal Information Databases* of Fig. 1. To proposing of precisely controllable social care aware movement actions by robot 1 and 2 for given user with movement disabilities, a real-time Off-Policy Agent Q-learning algorithm [4] was used:

$$Q(s,a) \leftarrow Q(s,a) + \alpha[r + \gamma \max_{a'} Q(s',a') - Q(s,a)]. \quad (2)$$

It was implemented by using multi-agent based human computer interaction system of Fig. 6. The system was constructed by using Java-based JACK agent oriented environment to laying-down an optimal path of robot in assisting a disabled person for a given his/her arousal context aware situation. The proposed multi-agent system of Fig. 6 permanently performs the following scenario: obtains data such as current position of robot and user's state information from intelligent robots; finds decision for given situation; sends signals for appropriate actions to objects of the system. Each time when new intelligent robot logs into the system, two dynamic agents, the *Dispatcher* and *RCS*, are created. The *Dispatcher* is responsible for TCP/IP-based communications between logged robot and system. When *Dispatcher* gets new message it creates an event *NewMessage*. The *NewMessage* has capability *IdentifyMessage* to recognizing what data obtained and where it was delivered. Then an event *NewCondition* is created for an agent *RCS*. The *RCS* (Remote Control System) controls an intelligent robot and sends data to the object which is found necessary to be updated in a given context aware situation. The *NewCondition* event has 4 plans: *GoodCondition*, *NormalCondition*, *BadCondition*, and *CriticalCondition*. By using new data as well as saved person's e-health history data obtained, one of 4 plans is performed. If plans *BadCondition* or *CriticalCondition* are being selected each plan creates 3 new events: *GoToBed*, *AskHelp*, and *InformDoctor*. The *GoToBed* event is responsible both for finding coordinates of a bed which is located at the nearest position to the logged into the system robot and for sending those coordinates to this robot. To performing that,

the *FindNearestBed* plan finds coordination of nearest bed, creates an event *MoveTo* and sends the address via agent *Dispatcher* to the robot for delivering the disabled person to this bed. An event *AskHelp* sends a message to the nearest dislocated of an appropriate help providing robot to approaching to the position of this bed for giving additional help for disabled person. An event *InformDoctor* informs doctor about situation of disabled person by using plans *viaSMS* or *viaInternet*. After creating each of these plans, for the agent *Dispatcher*, a plan *Respond* is now being created to delivering messages via TCP/IP to the intelligent robot. If situation of any individual in the system becomes critical a help message is sent to all of intelligent robots of the system. By given scenario, if such message is obtained a plan *InformationMessage* of the agent *Dispatcher* is performed. It then creates an event *HelpFriend*. If a necessity of providing such a help is discovered the plan *FinDirection* obtains coordinates where the disabled individual was being delivered, and another robot is directed to this place for providing social care aware help.

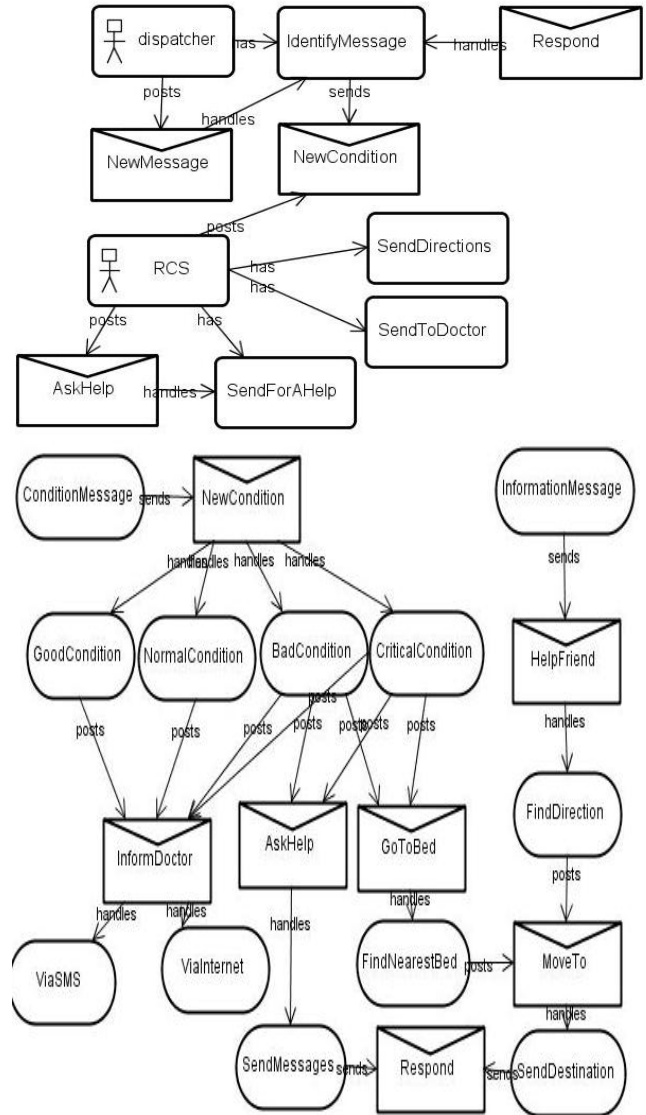

Fig. 6. Multi-agent based system: human-computer remote interaction block diagram

Conclusion

An approach proposed in creating of an intelligent e-health care environment by modelling of an adaptive multi-agent-based e-health and e-social care system for people with movement disabilities. Human's Arousal Recognition Module is described based on online recognition of human's ECG, EDA and Body temperature signals by using embedded Atmega32 type microcontrollers. Multi-agent based online motion control of two wheelchair-type robots realized on integration of real-time adaptive Fuzzy Neural Network Control algorithm into ATmega32 microcontroller. Human Computer Interaction in the system realized in providing of necessary e-health care support actions for users with some movement disabilities by using *Java*-based *JACK* agent oriented environment. To proposing of precisely controllable social care aware movement actions by social-care robots in the system for given user with movement disabilities, an *Off-Policy Agent Q-learning* algorithm has been implemented in real time. The dynamic multi-agent system is proposed to permanently realizing e-social care support actions for disabled by: gathering data such as current position of robot and user's state information from intelligent robots; finding decisions for given situation;

sending signals to performing appropriate actions of the objects in the system.

References

1. **Pentland A.** Healthwear: Medical Technology Becomes Wearable // *IEEE Computer*. – May 2004. – No. 37(5). – P. 42–49.
2. **Villon O., Lisett Ch.** A User-Modeling Approach to Build User's Psycho-Physiological Maps of Emotions using Bio-Sensors // *Proc. of IEEE Roman*. – 2006. – P. 269–276.
3. **Rubaii A., Ofoli A. R., Burge L., Garuba M.** Hardware Implementation of an Adaptive Network-Based Fuzzy Controller for DC–DC Converters // *IEEE Transactions on Industry Applications*. – 2005. – Vol. 41, No. 6. – P. 1557–1565.
4. **Watkins C. J.** Learning from Delayed Rewards / PhD thesis. – Cambridge University. – Cambridge, England. – 1989.
5. **Bielskis A. A., Denisov V., Kučinskis G., Ramašauskas O., Romas N.** Modeling of Human Physiological Parameters in an E-Laboratory by SOM Neural Networks // *Elektronika ir elektrotechnika*. – Kaunas: Technologija, 2007. – No. 3(75). – P. 77–82.

Submitted for publication 2008 02 27

A. A. Bielskis, V. Denisovas, D. Drungilas, G. Gričius, O. Ramašauskas. Modeling of Intelligent Multi-Agent based E-health Care System for People with Movement Disabilities // Electronics and Electrical Engineering. – Kaunas: Technologija, 2008. – No 6(86). – P. 37–42.

An approach is proposed in creating of an intelligent e-health care environment by modelling of an adaptive multi-agent-based e-health and e-social care system for people with movement disabilities. Human's Arousal Recognition Module (HARM) described based on online recognition of human's ECG, EDA and body temperature signals by using embedded Atmega32 type microcontrollers. Multi-agent based online motion control of multiple wheelchair-type robots is realized based on integration of an adaptive Fuzzy Neural Network Control algorithm into ATmega32 microcontroller. Human Computer Interaction in the system is realized in providing of necessary e-health care support actions for users with some movement disabilities by using *Java*-based *JACK* agent oriented environment. The dynamic multi-agent system is proposed to permanently realizing e-social care support actions for disabled by gathering data such as current position of robot and user's state information; finding decisions for given situation; sending signals to performing appropriate actions of the objects in the system. Ill. 6, bibl. 5 (in English; summaries in English, Russian and Lithuanian).

A. A. Бельскис, В. Денисовас, Д. Друнгилас, Г. Грицюс, О. Рамашаускас. Моделирование интеллектуальной системы э-здоровья для людей с недугом по подвижности // Электроника и электротехника. – Каунас: Технология, 2008 – № 6(86). – С. 37–42.

Предложена модель многоагентной системы по предоставлению э-услуг для людей с недугом по подвижности. Разработанная модель (HARM) базируется на автоматическом опознавании человеческих эмоций с применением EDA, ECG, температурных датчиков и ATmega32 микроконтроллеров, адаптивных, статистических инструментов и искусственной нейронной сети. Человеческо-компьютерное общение в системе реализовано через действующую на *Java-based JACK* оболочке многоагентную систему, которая собирает данные о деятельности системы, принимает решения в заданных ситуациях, ведет управление объектами по предоставлению адекватной в данной ситуации социальной помощи для людей с недугом по подвижности. Ил. 6, библи. 5 (на английском языке; рефераты на английском, русском и литовском яз.).

A. A. Bielskis, V. Denisovas, D. Drungilas, G. Gričius, O. Ramašauskas. Intelektualios daugiaagentės e.sveikatos paslaugų sistemoms judėjimo negalią turintiems asmenims modeliavimas // Elektronika ir elektrotechnika. – Kaunas: Technologija, 2008. – Nr. 6(86). – P. 37–42.

Pasiūlytas intelektualios agentinės sistemos modelis e.sveikatos ir e.socialinės rūpybos paslaugoms judėjimo negalią turintiems žmonėms teikti. Sukurtas modelis (HARM) paremtas nutolusiuoju žmogaus emocijų tyrimu per EDA, ECG ir temperatūros jutiklius bei ATmega32 valdiklius dirbtinių neuronų adaptyviame tinkle, naudojant miglotuosius algoritmus ir statistinius metodus. Žmogaus ir kompiuterio bendravimas sistemoje vyksta per sukurtąją *JACK* (Java programavimo kalbos dialektas) pagrindu veikiančią daugiaagentę sistemą, renkančią duomenis apie sistemos veiklą, priimančią sprendimus esamoje situacijoje, valdančią objektus pagal tą situaciją teikiančią e.sveikatos rūpybos paslaugas į sistemą įsijungusiems neįgaliesiems. Il. 6, bibl.5 (anglų kalba; santraukos anglų, rusų ir lietuvių k.).

