

Direct Current Drive with Observer

R. Rinkevičienė, A. Petrovas

*Automation department, Vilnius Gediminas technical university,
 Naugarduko str. 41, LT-03227, Vilnius, Lithuania; e-mail: roma.rinkeviciene@el.vgtu.lt*

Introduction

The most expensive part of control system is the sensors and their cabling system. Obviously, these additionally elements reduce reliability of the system. Beside that, sometimes not all signals can be measured because the objects being measured may be inaccessible for harsh environment. Usually sensors induce significant errors, such as noise, deterministic errors and limited responsiveness [1]. Observers can be used to complement or replace sensors in the control systems, where proper difficulties appear to use sensors [2, 3].

Designing, modeling and simulation of direct current drive with reduced order observer is presented in the paper.

Model of direct current drive with full order observer

Mathematical model of direct current separate excitation drive comprises two differential equations: KVL for armature circuit and equation of movement [4]. If the armature current and angular speed of armature are chosen as state-space variables, ($x_1 = \omega$ and $x_2 = i_a$), the system of differential equations of state variables can be expressed as:

$$\begin{bmatrix} \dot{x}_1 \\ \dot{x}_2 \end{bmatrix} = \begin{bmatrix} \frac{-R_a}{L_a} & \frac{-k_e}{L_a} \\ \frac{k_m}{J} & \frac{-B}{J} \end{bmatrix} \cdot \begin{bmatrix} x_1 \\ x_2 \end{bmatrix} + \begin{bmatrix} \frac{1}{L_a} & 0 \\ 0 & \frac{-1}{J} \end{bmatrix} \cdot \begin{bmatrix} u_a \\ 0 \end{bmatrix} \quad (1)$$

or using abbreviations it can be rearranged as:

$$\dot{\mathbf{x}} = \mathbf{Ax} + \mathbf{Bu}, \quad (2)$$

where \mathbf{x} – state vector: $\mathbf{x} = \begin{bmatrix} x_1 \\ x_2 \end{bmatrix}$; $\dot{\mathbf{x}}$ – state derivatives

vector: $\dot{\mathbf{x}} = \begin{bmatrix} \dot{x}_1 \\ \dot{x}_2 \end{bmatrix}$; \mathbf{u} – input vector $\mathbf{u} = \begin{bmatrix} u_a \\ 0 \end{bmatrix}$; \mathbf{A} – system

matrix: $\mathbf{A} = \begin{bmatrix} \frac{-R_a}{L_a} & \frac{-k_e}{L_a} \\ \frac{k_m}{J} & \frac{-B}{J} \end{bmatrix}$; \mathbf{B} – control matrix:

$$\mathbf{B} = \begin{bmatrix} \frac{1}{L_a} & 0 \\ 0 & \frac{-1}{J} \end{bmatrix}.$$

Parameters of motor is to be simulated are presented in Table 1.

Table 1. Parameters of DC motor

Parameter	R_a , [Ω]	L_a , [H]	k_m , [N·m/A]	J , [kg·m ²]	B , [N·s]	k_e , [V·s]
Value	0.5	0.015	0.5	0.00025	0.0001	0.05

Simulink model of full order observer is presented in [5]. Step response analysis of system with full order observer indicates the transient time of 20 ms and overshoot not exceeding 7%. The main problem in designing of full order observer is calculation of feedback gain vector. Properly calculated feedback gains allow designing system meeting all requirements for response. The main problem is selection of characteristic equation, corresponding to desired response and calculation of feedback gains according to J. E. Ackermann formula.

If it is required to get settling time of the drive $T_m = 0,01$ s and overshoot as well as steady-state error not exceeding 5%, then characteristic equation of closed loop system is calculated according to recommendations, given in [6] and can be written as:

$$\left(\frac{s}{480}\right)^2 + \left(\frac{1.4}{480}\right)s + 1 = 0. \quad (3)$$

Feedback gain matrix is calculated according to Ackermann's formula with respect to characteristic equation and matrixes \mathbf{A} and \mathbf{B} , and has the form:

$$\mathbf{K}_{Ak} = [0 \ 1] \cdot [\mathbf{B} \ \mathbf{AB}]^{-1} d(\mathbf{A}) = [0.6802 \ 0.1226], \quad (3)$$

where \mathbf{K}_{Ak} – feedback gain matrix and $d(\mathbf{A})$ – matrix polynomial.

Design of reduced order observer

Output variable of designed system, i.e. armature speed coincides with one state variable, therefore it is measured directly and that gives possibility to apply reduced order observer. Such observer according to output signal, with its state variable, calculates other state variable x_2 . The main advantage of reduced order observer is gained in the order of observer differential equations lower than plant.

Control system with measured state variable x_1 can be described by equations of state variables as:

$$\begin{bmatrix} \dot{x}_1 \\ \dot{x}_e \end{bmatrix} = \begin{bmatrix} a_{11} & \mathbf{A}_{1e} \\ \mathbf{A}_{e1} & \mathbf{A}_{ee} \end{bmatrix} \begin{bmatrix} x_1 \\ x_e \end{bmatrix} + \begin{bmatrix} b_1 \\ \mathbf{B}_e \end{bmatrix} u_a, \quad (4)$$

where x_e – vector of estimated state variables and \mathbf{A}_{ee} replaces \mathbf{A} as well as \mathbf{A}_{1e} replaces \mathbf{C} in full order observer..

State variable vector x_e of reduced order observer is calculated as [2]:

$$\hat{\mathbf{x}}_e = \hat{\mathbf{x}}_{e1} + \mathbf{K}_e y, \quad (5)$$

where \mathbf{K}_e – observer feedback gain matrix, $\hat{\mathbf{x}}_e$ – vector of estimated state variables, y – output of the system.

Derivative of variable $\hat{\mathbf{x}}_{e1}$, entering (5), is calculated from expression:

$$\begin{cases} \dot{\hat{\mathbf{x}}}_{e1} = (\mathbf{A}_{ee} - \mathbf{K}_e) \hat{\mathbf{x}}_{e1} + \\ (\mathbf{A}_{e1} - \mathbf{K}_e a_{11} + \mathbf{A}_{ee} \mathbf{K}_e - \mathbf{K}_e \mathbf{A}_{1e} \mathbf{K}_e) + \\ (\mathbf{B}_e - \mathbf{K}_e b_1) u_a \end{cases} \quad (6)$$

Feedback gain K_e of observer is calculated with respect to roots of desired characteristic equation of observer, i.e. it is calculated from equation:

$$|s\mathbf{I} - \mathbf{A}_{ee} + \mathbf{K}_e \mathbf{A}_{1e}| = \sum_{k=0}^n \alpha_{ne} s^n, \quad (7)$$

where α_{ne} – coefficients of desired characteristic equation and \mathbf{I} is identity matrix.

Observer is designed in the way to match transfer functions, relating system input and each state variable of observer and real system. Therefore the system matrix \mathbf{A} of (4) and (1) is to be equal:

$$\begin{bmatrix} a_{11} & \mathbf{A}_{1e} \\ \mathbf{A}_{e1} & \mathbf{A}_{ee} \end{bmatrix} = \begin{bmatrix} -B/J & k_m/J \\ -k_e/L_a & -R_a/L_a \end{bmatrix}. \quad (8)$$

As the system feedback matrix was calculated according to (3) to ensure settling time 10 ms, therefore the observer response time should be twice shorter, i.e. 5 ms [4]. Then desired characteristic equation of observer is:

$$s + \frac{R_a}{L_a} + K_e \frac{k_m}{J} = s + 1000 \quad (9)$$

and feedback gain of observer K_e is calculated with consideration of (7) and (8) to yield $K_e = 0.333$.

(9) is the first order equation, therefore K_e is entering that, is scalar value.

Developed reduced order observer for direct current motor is presented in Fig. 1.

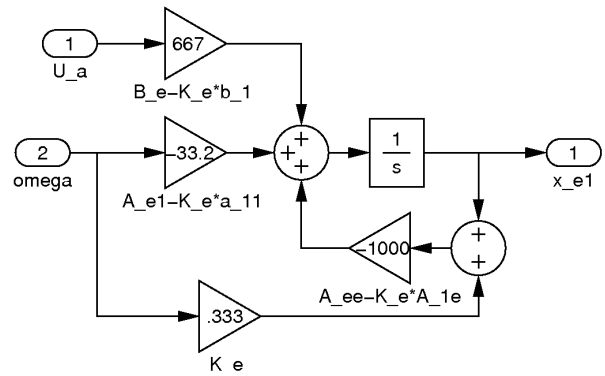

Fig. 1. Reduced order observer

All blocks in the Fig. 1 compose subsystem, which is connected to model of direct current drive. Subsystem is provided with two inputs: armature voltage u_a and armature angular speed ω as well as one output auxiliary variable x_{e1} , which is related with observer state variable by Eq. 5.

Current controller

As the current is one of state variables the employment of current inverter allows controlling the motor current directly. Electrical circuit of proposed controller is given in Fig. 2.

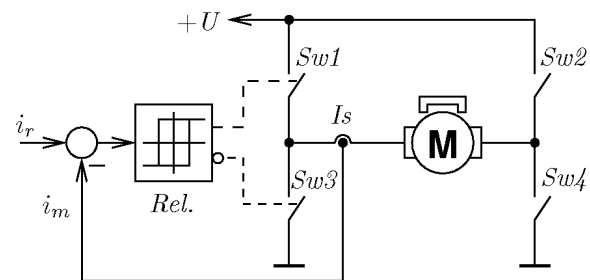

Fig. 2. Electrical circuit of current controller

Electrical circuit in Fig. 2 is composed from four controlled switches SW1 – SW4 and the current sensor I_s measuring the armature current. Current is controlled by switches SW1 and SW3, the other two switches SW2 and SW4 are used to change direction of rotation. Current, measured by current sensor I_s is being compared with reference current value i_r . Error signal controls relay R_{el} . Relay has hysteresis loop of Δi width. While $i_n - i_m > \Delta i / 2$, relay is turned on therefore the switch SW1 is switched off and switch SW3, connected to inverted relay contact is switched on. At this position of switches contacts, the motor armature is supplied by voltage U and current increases in the armature winding.

When the current reaches value $i_m - i_n > \Delta i / 2$, relay turns off and switch SW1 is switched on. In the same way switch SW3 is switched off. Results give the short circuit, placed across armature winding and armature current is reduced. Controller allows keeping current value, equal to reference with error $\Delta i / 2$.

Model of the drive

Model of motor and observer, together with feedback compose model of electric drive. Simulink model of considered drive is given in Fig.3. Model of direct current motor is placed in the subsystem.

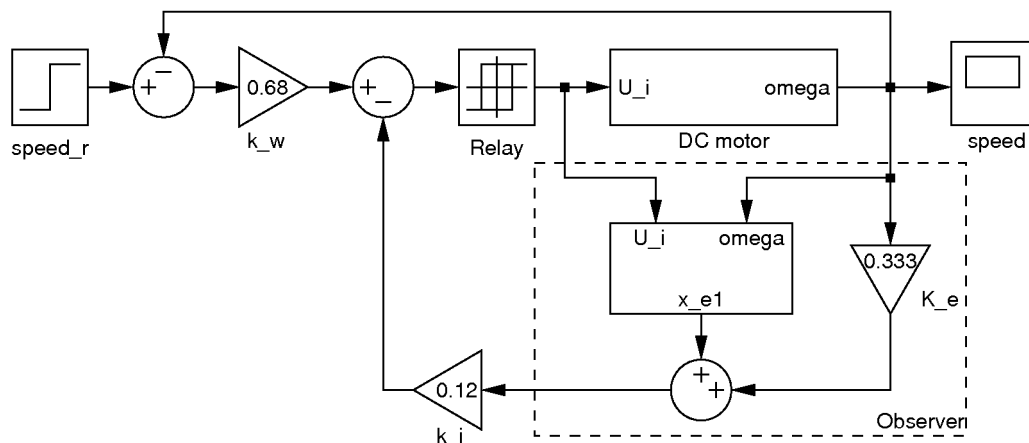

Fig. 3. Simulink model of the drive

Input of the motor is armature voltage u_a and output is angular velocity ω . Both two signals are inputs of observer; therefore they should be measured in the real system. The other state variable, i.e., armature current is estimated by observer according to armature voltage and angular velocity signals. Model of observer is denoted by dash line in Fig. 3.

Simulation results

Step response of motor angular speed is presented in Fig. 4.

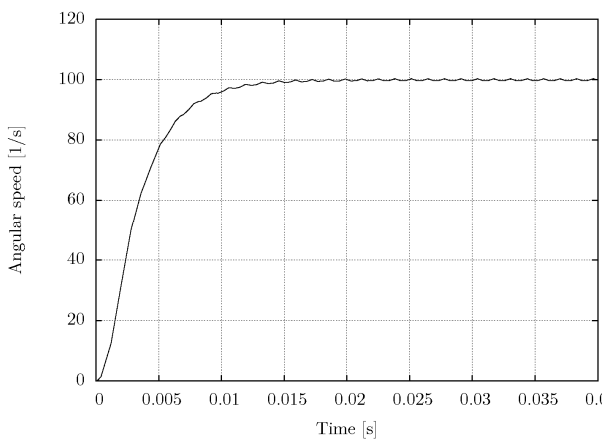

Fig. 4. Step response of motor angular speed

Steady-state value of motor angular speed is 100 1/s and is characterized by ripples. Amplitude of ripples does not exceed 3% of steady state value, and can be reduced by diminishing hysteresis loop width of relay. Simulation results indicate settling time greater than desired 10 ms by 20-30%.

Step response of armature current is shown in Fig. 5.

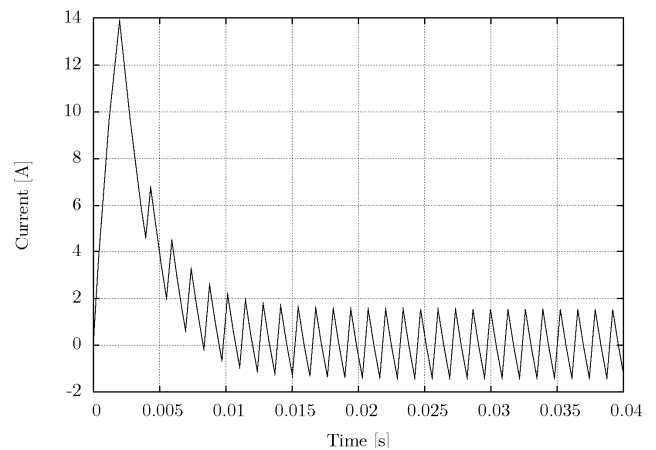

Fig. 5. Step response of motor armature current

Current pulsates with amplitude approximately of 12% less than starting current.

Conclusions

1. Designed reduced order observer estimates armature current according to motor supply and angular speed values, therefore there is no need for current sensor. Proposed method reduces price of the drive and increases its reliability.
2. Application of stabilized voltage source allows canceling voltage sensor and avoiding of any measurement of electrical quantities.
3. Proposed nonlinear current controller allows controlling one of state variables (current) directly and elimination requirement to apply controlled direct current voltage source.
4. Designed controller is described by fast order differential equations and its algorithm can be programmed in the embedded systems.
5. Shortcoming of considered system lies in ripples of steady state speed up to 3% of rated and increased settling time up to 20%. This disadvantage can be reduced by

application of relay with narrow hysteresis loop but that is limited by maximal frequency of operation inverter switches.

References

1. **Ellis G.** Observers in Control Systems. – Academic Press, 2002.
2. **Burns R. S.** Advanced Control Engineering. – Butterworth Heinemann, 2001.
3. **Balasevicius L., Janusevicius V. S., Zakaraite S.** State controller design in Programmable Logical Controllers // Electronics and Electrical Engineering. – Kaunas: Technologija, 2008. – No. 1(81). – P. 19–22.
4. **Schröder D.** Elektrische Antriebe – Regelung von Antriebssystemen. – Springer-Verlag, 2001.
5. **Petrovas A., Rinkeviciene R., Lisauskas S.** Design of observer for direct current drive // In press.
6. **Heinz, M., Horst S., Rainer F.** Einführung in die Regelungstechnik. 8 Auflage. – Carl Hanser Verlag München. – Wien, 2000. – 430 p.

Submitted for publication 2008 03 15

R. Rinkevičienė, A. Petrovas. Direct Current Drive with Observer // Electronics and Electrical Engineering. – Kaunas: Technologija, 2008. – No. 5(85). – P. 73–76.

Design of direct current drive with reduced order observer, applied for estimation of armature current is analyzed. Current is controlled by relay controller with hysteresis loop. This method allows avoiding of controllable direct current voltage source. The system requires to measure just one output signal – motor speed. Due to this reason electric drive has simple, cheap and safe construction. Comprehensive analysis of state variable feedback vector design is presented. Simulink model of the drive is elaborated. Step responses of motor speed and armature current are presented and analyzed. Ill. 5, bibl. 6 (in English; summaries in English, Russian and Lithuanian).

Р. Ринкявичене, А. Петровас. Привод постоянного тока с наблюдателем // Электроника и электротехника. – Каунас: Технология, 2008. – № 5(85). – С. 73–76.

Обсуждается привод постоянного тока, в котором для оценки тока якоря двигателя использован наблюдатель пониженного порядка, а для управления тока применяется релейный регулятор с гистерезисом. При таком управлении в приводе становится ненужным регулируемый источник постоянного тока, а скорость вращения якоря остается единственной величиной, которая должна измеряться непосредственно, что делает описываемый привод простым, надежным и безопасным. Детально приводится методика расчета наблюдателя и коэффициентов обратной связи по состоянию. Для программы «Simulink» построена имитационная модель, результаты работы которой, переходные процессы тока и скорости якоря, анализируются в статье. Ил. 5, библи. 6 (на английском языке; рефераты на английском, русском и литовском яз.).

R. Rinkevičienė, A. Petrovas. Nuolatinės srovės pavara su stebikliu // Elektronika ir elektrotechnika. – Kaunas: Technologija, 2008. – Nr. 5(85). – P. 73–76.

Nagrinėjama nuolatinės srovės pavara, kurioje variklio inkaro srovei vertinti panaudotas sumažintos eilės stebiklis, o pati srovė valdoma naudojant relinį srovės reguliatorių su histerezės kilpa. Taip valdant srovę, pavaroje nebereikalingas reguliuojamas nuolatinės įtampos šaltinis, o vienintelis dydis, kurį būtina matuoti tiesiogiai, yra variklio inkaro kampinis greitis, todėl nagrinėjama pavara pasižymi paprasta, pigia ir saugia konstrukcija. Pateikiama detali grįžtamojo ryšio būsenos kintamųjų vektoriaus bei stebiklio projektavimo metodika. Sudarytas „Simulink“ programai pritaikytas pavaros modelis. Pateikiami ir analizuojami imitavimo metu gauti greičio bei srovės pereinamieji procesai. Il. 5, bibl. 6 (anglų kalba; santraukos anglų, rusų ir lietuvių k.).

DOI: 10.5755/j02.eie.11166